

Application Example

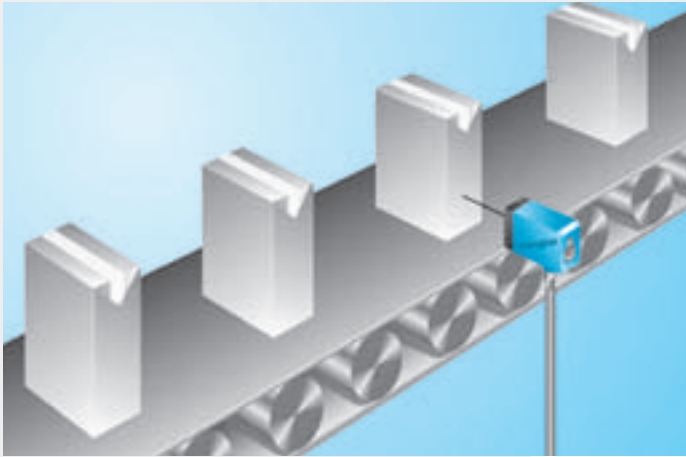

Monitoring of the material flow
Diffuse Reflex Sensor

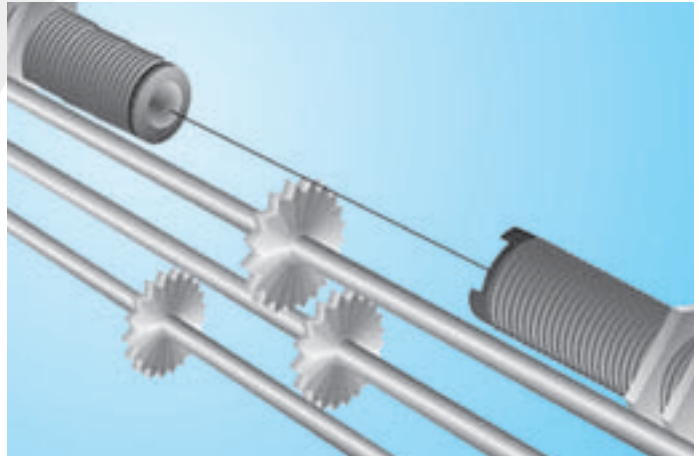

Gearwheel monitoring
Through Beam Barrier (Laser)

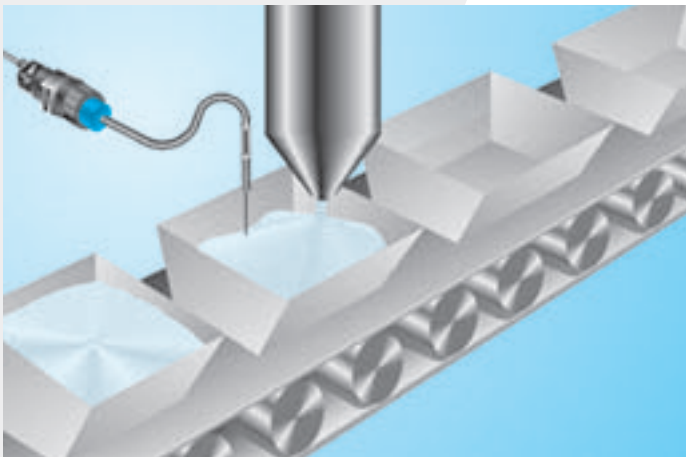

Filling level measurement
Analogue Universal Diffuse Reflex Sensor with Glass Fibre Optic Cable
Universal Diffuse Reflex Sensor for distance measuring

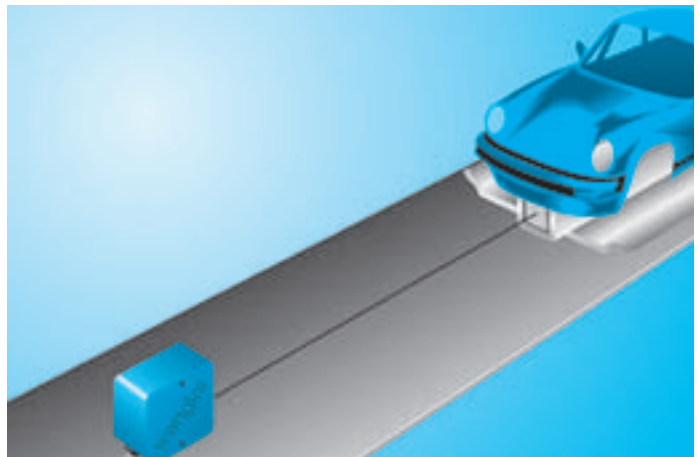

Positioning up to 100 m
Transit Time Measurement sensor for distance measuring

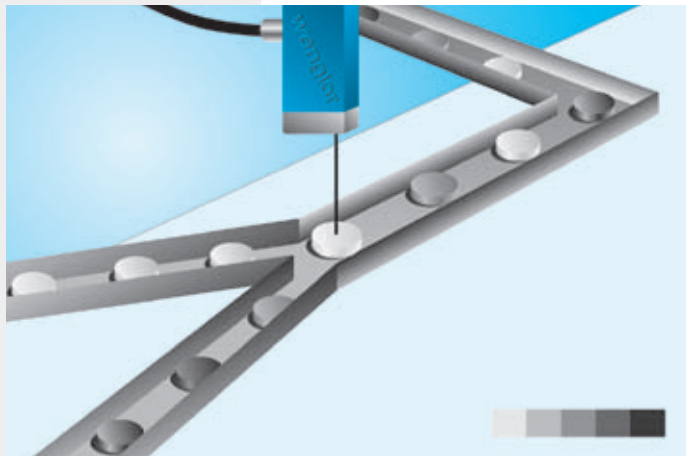

Diffuse Reflex Sensor for contrast recognition
Print mark sensor

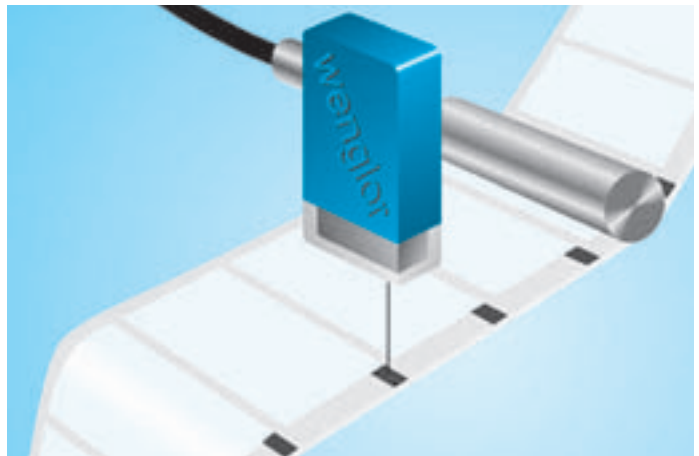

Print- and colour mark detection
Print Mark Sensor

Application Example

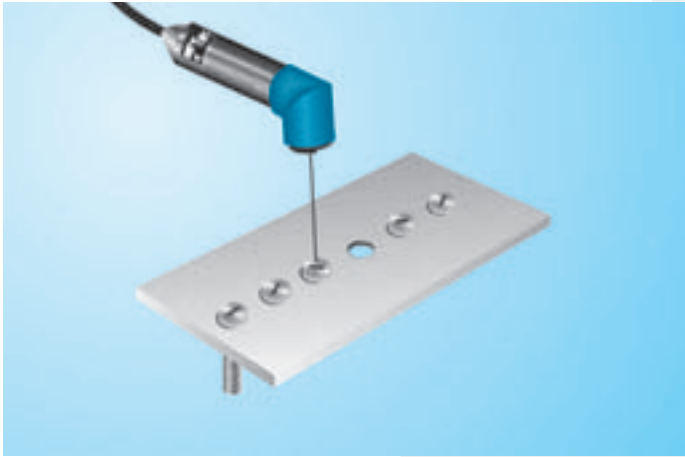

Assembly inspection
Diffuse Reflex Sensor with background suppression (Laser)

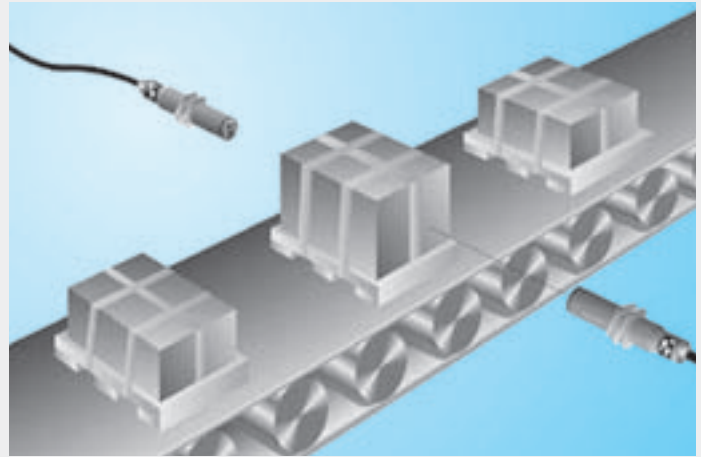

Recognition of various objects
Through Beam Barriers

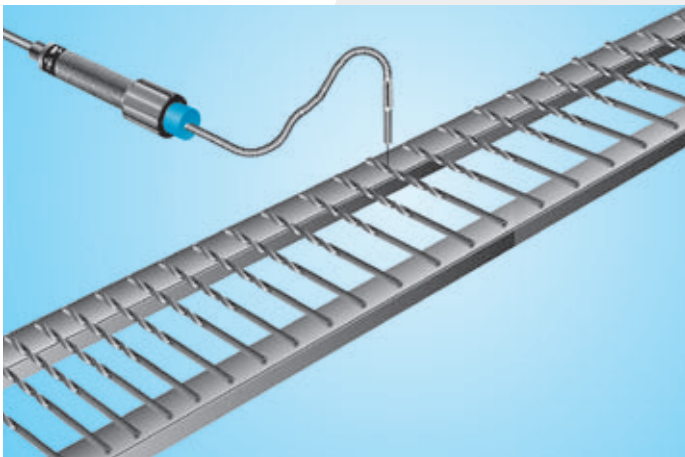

Counting of various objects
Universal Diffuse Reflex Sensor for fibre optic cable

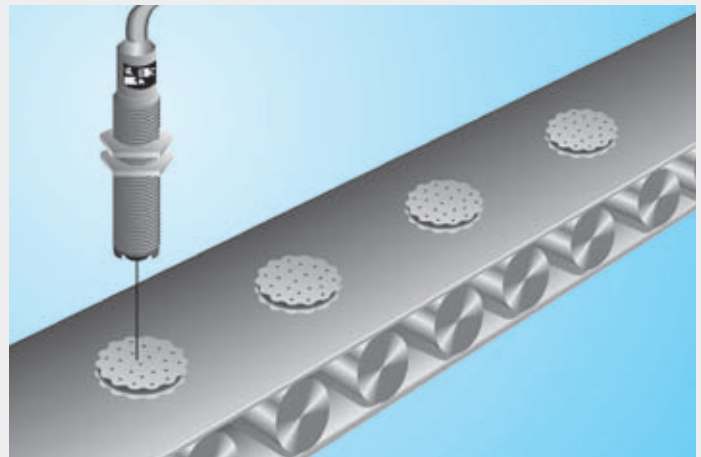

Recognition in front of background
Diffuse Light Sensor with background suppression



Web edge guider
Analogue Universal Diffuse Reflection Sensor with Glass Fibre Optic Curtain



Presence check
Universal Diffuse Reflex Sensor for fibre optic barrier, Through Beam Barrier

Application Example

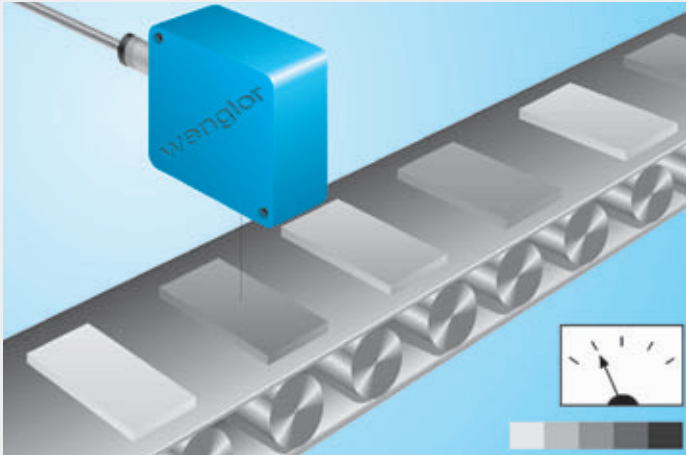

Measuring of different levels of luminosity
Diffuse Reflex Sensor for contrast measurement

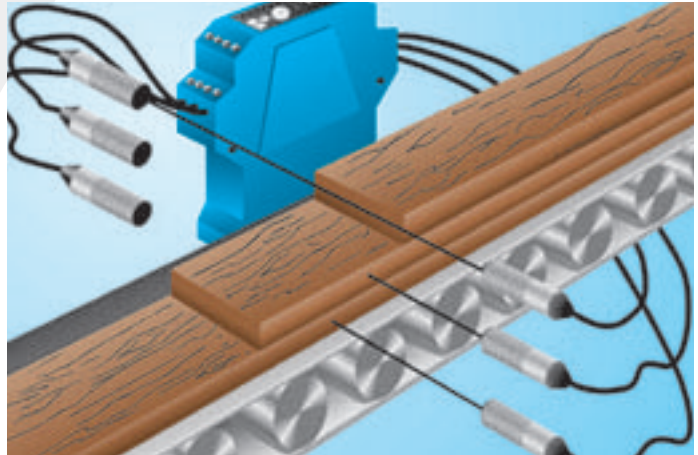

Monitoring of heights in extremely dirty environment
Through Beam Barriers

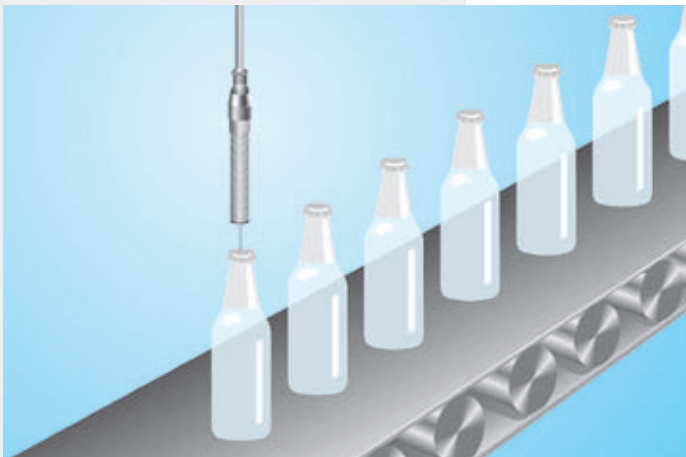

Monitoring of sealing caps
Diffuse Reflex Sensor with background suppression

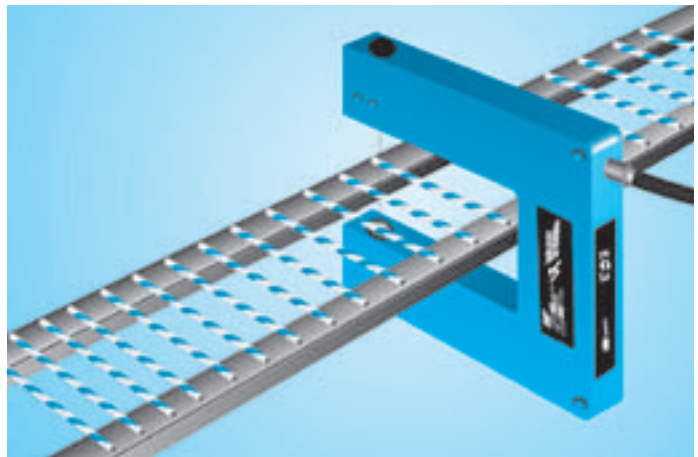

Presence check
Fork Sensors



Sorting of coloured fluids
Colour Sensors

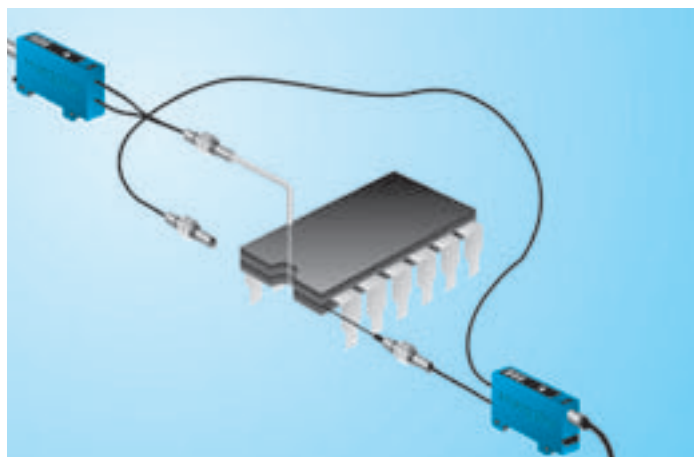

Edge detection and monitoring of parts
Diffuse Reflex Sensor for fibre optic connection

Application Example

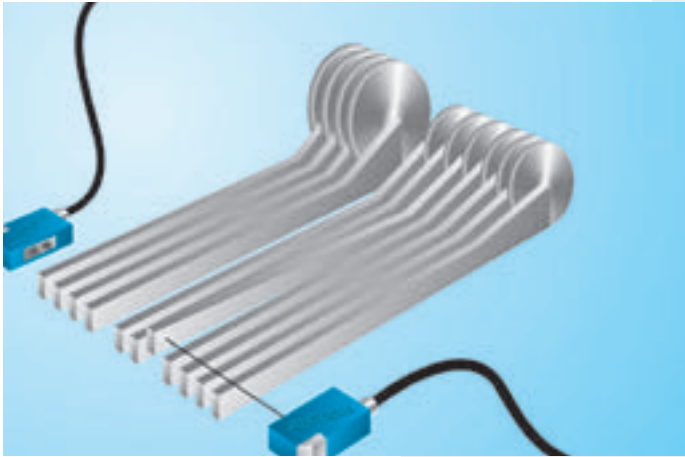

Monitoring of heights
Through Beam Barrier

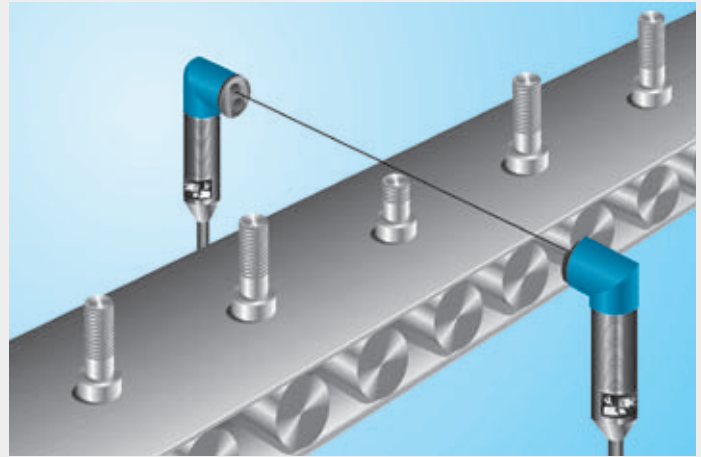

Monitoring of heights
Through Beam Barrier



Layer monitoring and positioning
Fork Sensor

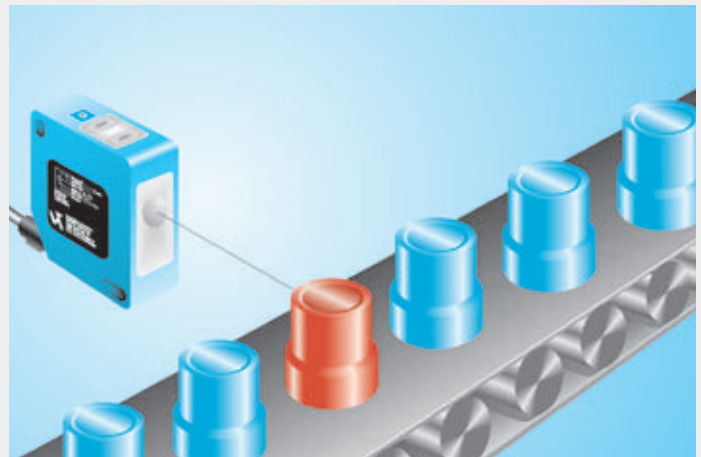

Sorting and controlling of coloured objects
Colour Sensor

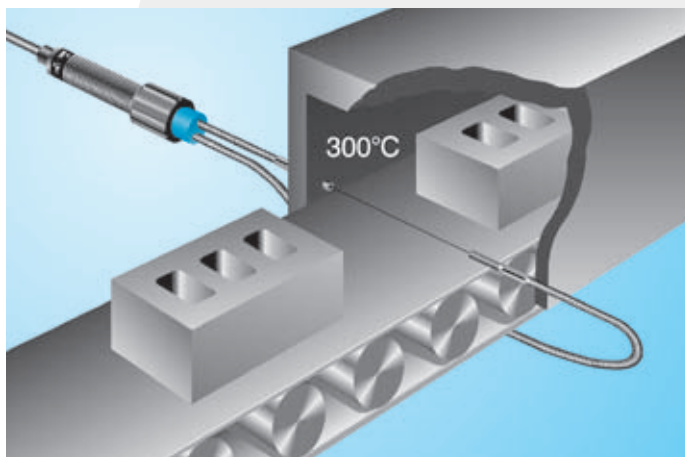

Presence check in extremely dirty and hot environment
Universal Diffuse Reflex Sensor for fibre optic barrier

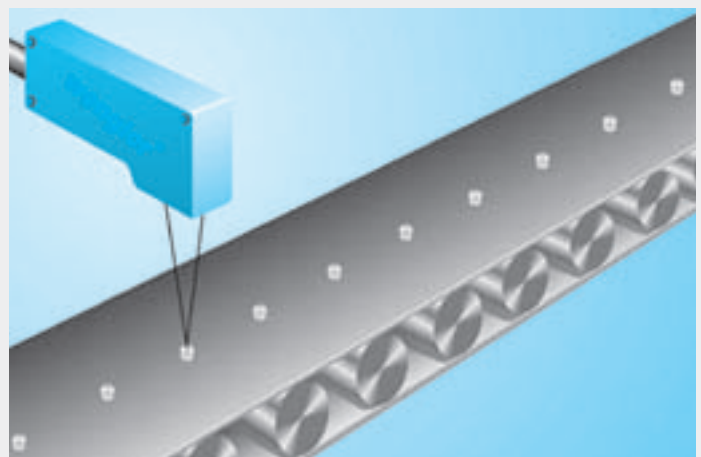

Recognition of smallest parts in front of a disturbing background
Diffuse Light Sensor with background suppression (Laser)

Application Example

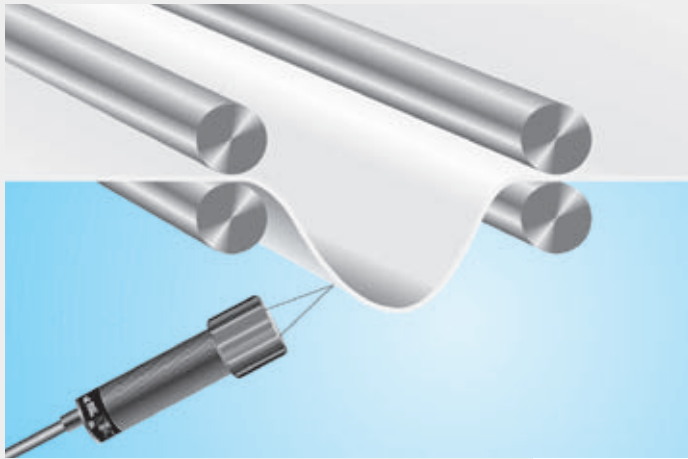

Loop tension control
 Analogue Universal Diffuse Reflection Sensor
 Diffuse Reflex Sensor for distance measurement

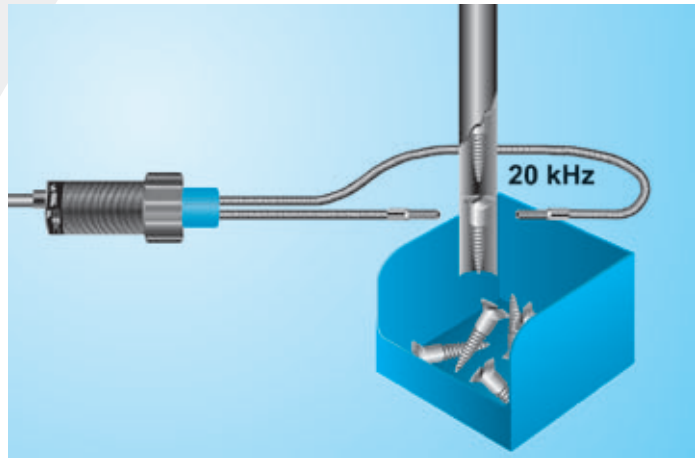

Detection of ejected objects
 Universal Diffuse Reflex Sensor for fibre optic barrier



Thread Recognition
 Universal Diffuse Reflex Sensor for fibre optic cable

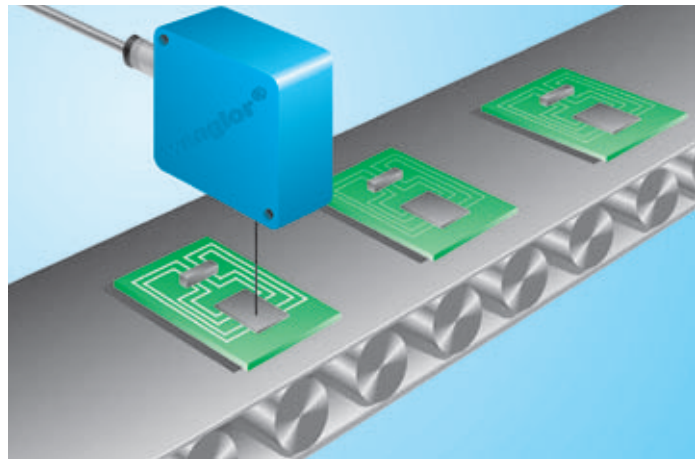

Quality management
 Diffuse Reflex Sensor with background suppression (Laser)

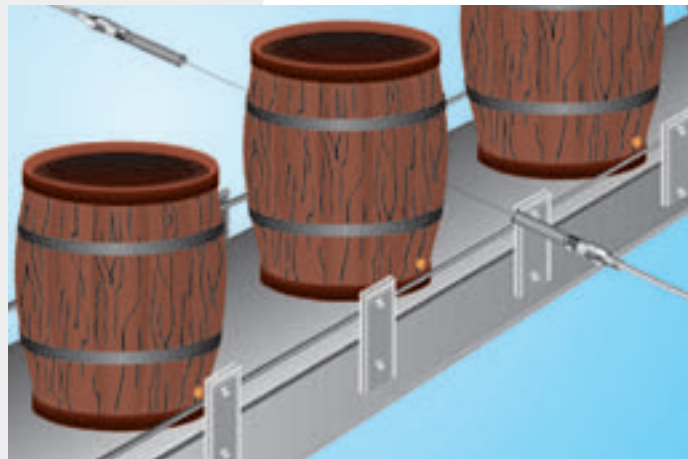

Recognition of various objects
 Through Beam Barrier



Positioning
 Diffuse Reflex Sensor (with background suppression)

Application Example

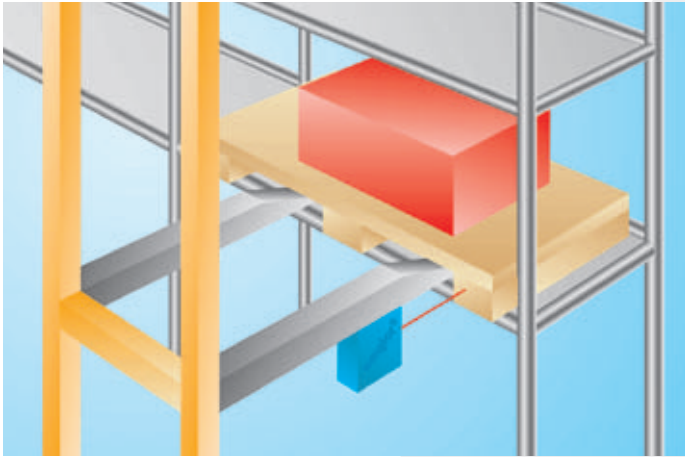

Location full message from automated storage vehicles
Diffuse Reflex Sensor with background suppression
Transit Time Measurement sensors for distance measuring

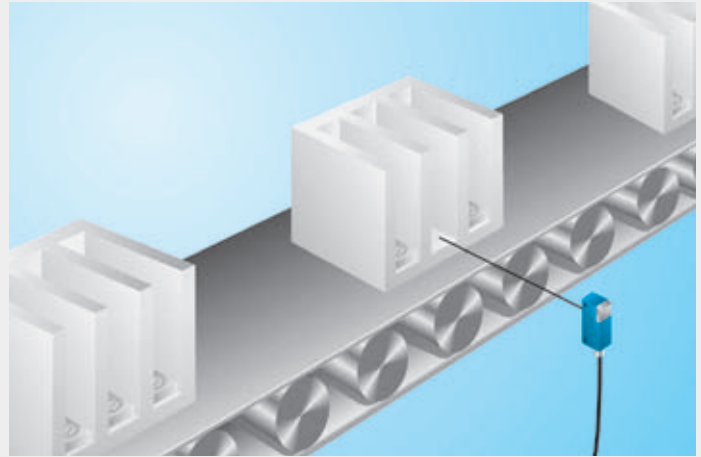

Assembly inspection
Diffuse Reflex Sensor with background suppression

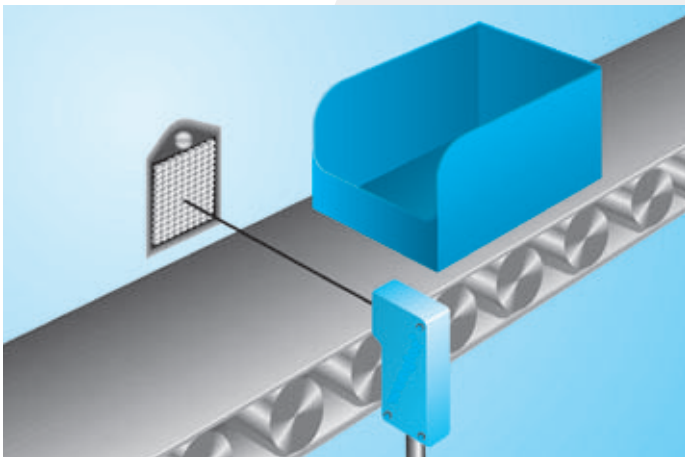

Recognition of various objects
Retro Reflective Barrier

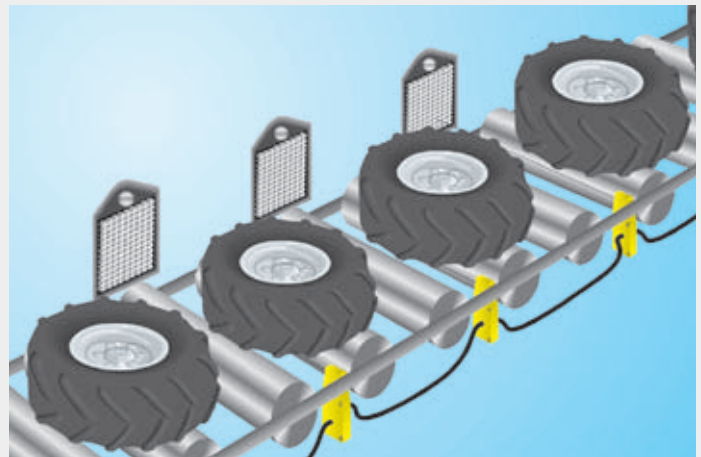

Accumulation monitoring in Roller Conveyor Systems with high polished or deep black objects
Retro Reflective Barrier for Roller Conveyor Systems

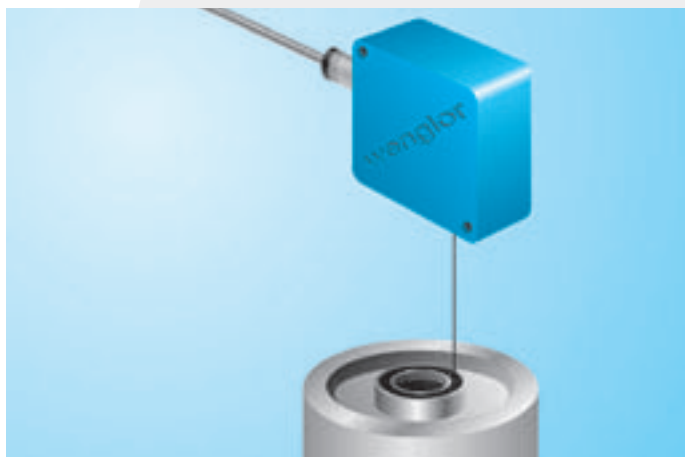

Quality monitoring
Diffuse Reflex Sensor with background suppression (Laser)

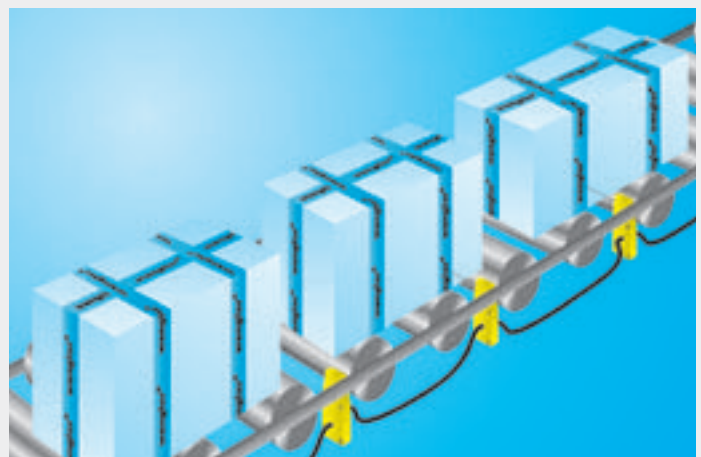

Accumulation monitoring in Roller Conveyor Systems
Diffuse Reflex Sensor for Roller Conveyor systems

Application Example



Filling level monitoring
Diffuse Reflex Sensor for distance measurement

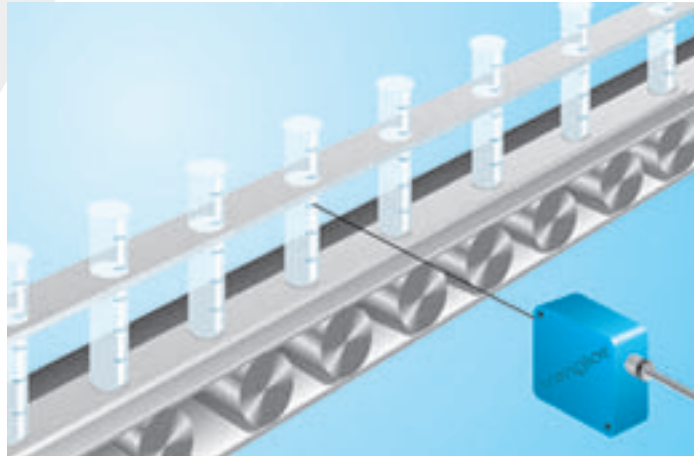

Recognition of contrast marks
Diffuse Reflex Sensor for contrast recognition
Print Mark Sensor

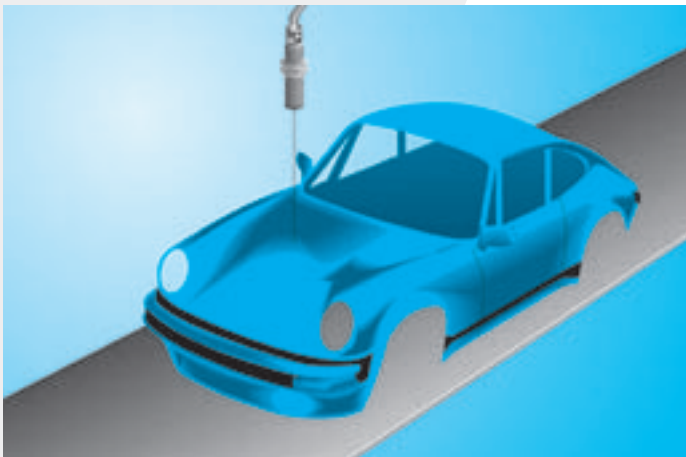

Monitoring of the material flow
Diffuse Reflex Sensor

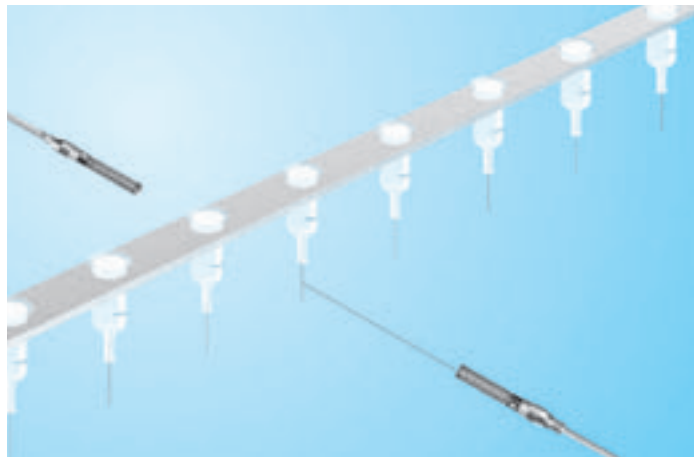

Check on attendance of smallest parts
Through Beam Barriers (Laser)



Recognition of objects in extremely dirty and wet environment
Diffuse Reflex Sensor (with housetop optic)

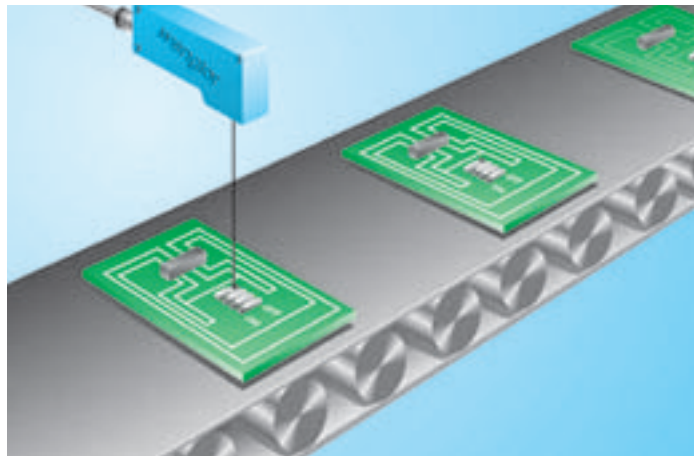

Assembly inspection
Diffuse Reflex Sensor with background suppression (Laser)

Application Example

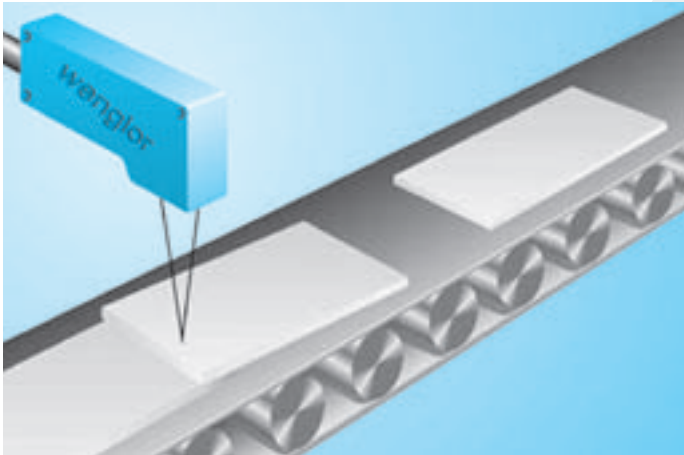

Double sheet detection
Diffuse Reflex Sensor with background suppression (Laser)

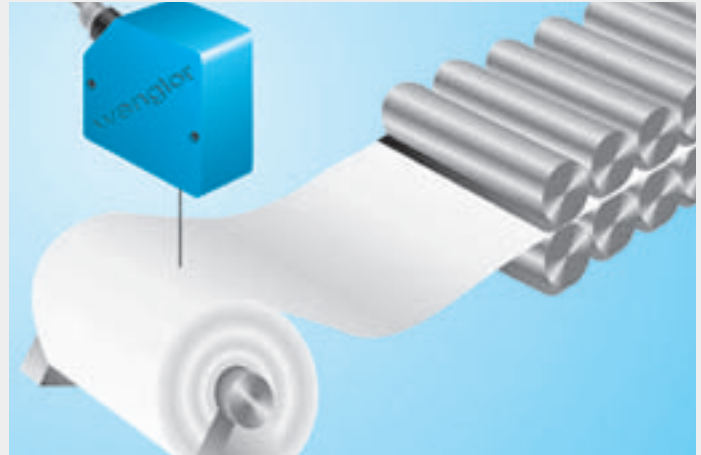

Measuring of coil diameters
Diffuse Reflex Sensor for distance measurement
Distance measuring with Time Transit Measurement

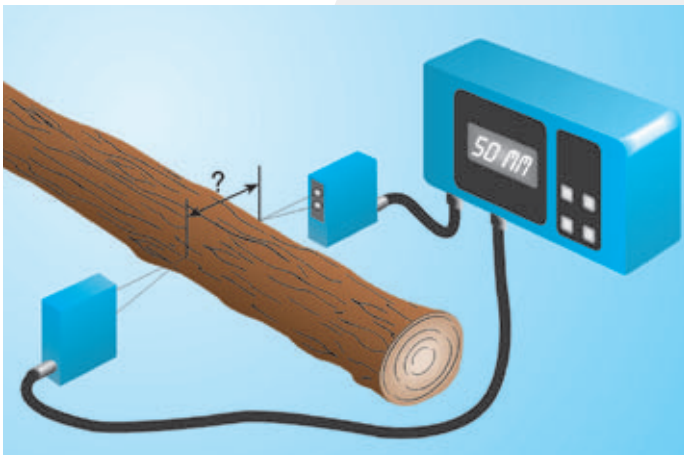

Evaluation of analogue sensor signals
Menu-driven Evaluation Unit

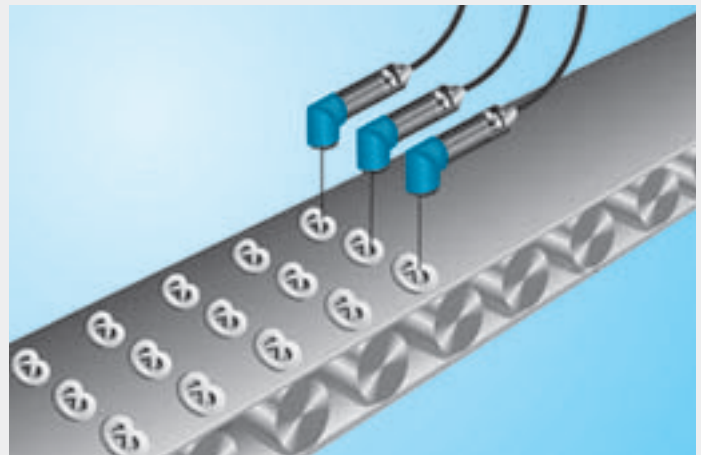

Recognition of objects from the top in front of a disturbing background
Diffuse Reflex Sensor with background suppression

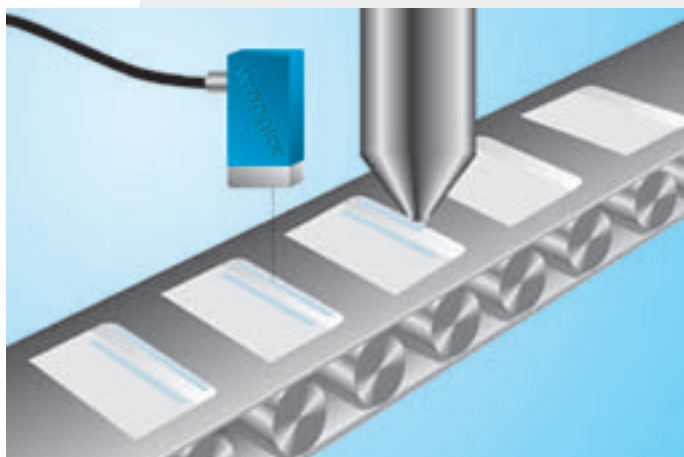

Monitoring of adhesives
Gloss Sensor



Recognition of transparent PET objects
Retro Reflective Barrier for clear glass recognition

Application Example



Recognition of transparent PET objects
Retro Reflective Barrier for clear glass recognition

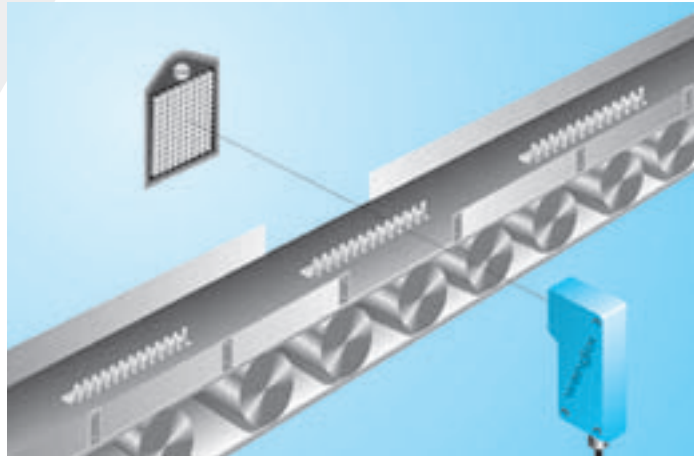

Recognition of smallest parts
Retro Reflective Barrier (Laser)

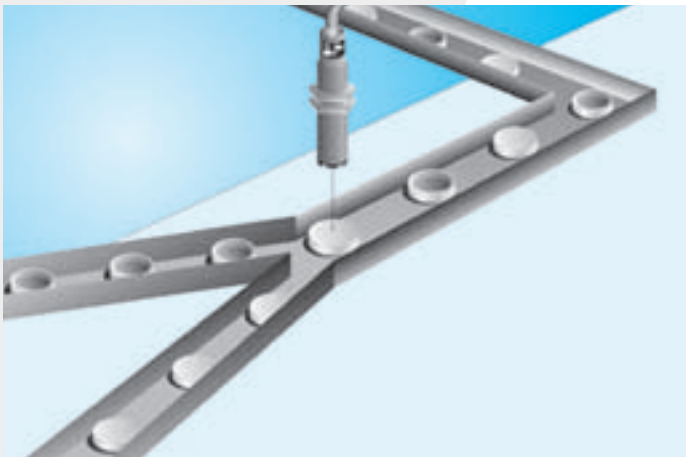

Layer monitoring
Diffuse Reflex Sensor with background suppression

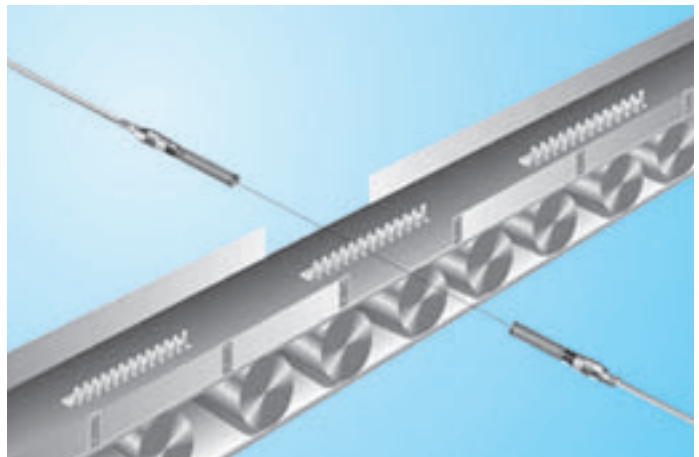

Counting of smallest parts
Through Beam Barriers (Laser)

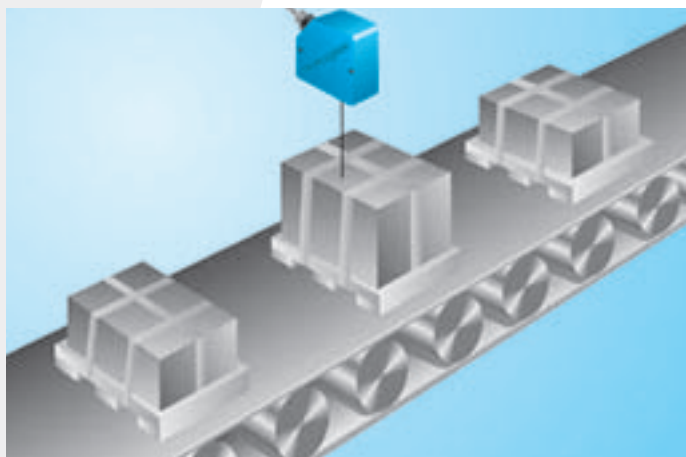

Recognition of objects from the top at great distance
Transit Time Measurement sensors for distance measuring
Diffuse Reflex Sensor with background suppression

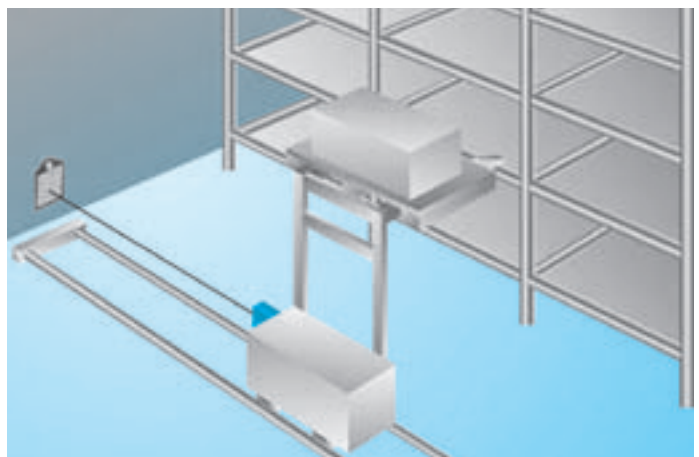

Position sensing for automated storage vehicles
Transit Time Measurement sensors for distance measuring

Application Example



Distance monitoring in trolley conveyor systems
Transit Time Measurement sensors for distance measuring

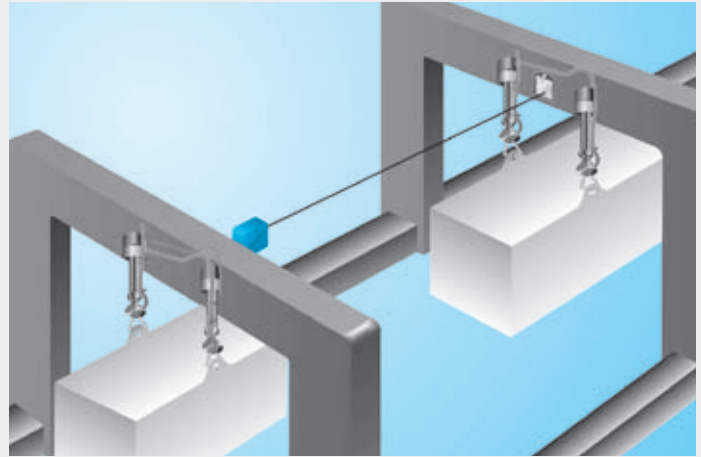

Distance monitoring in overhead cranes
Transit Time Measurement sensors for distance measuring

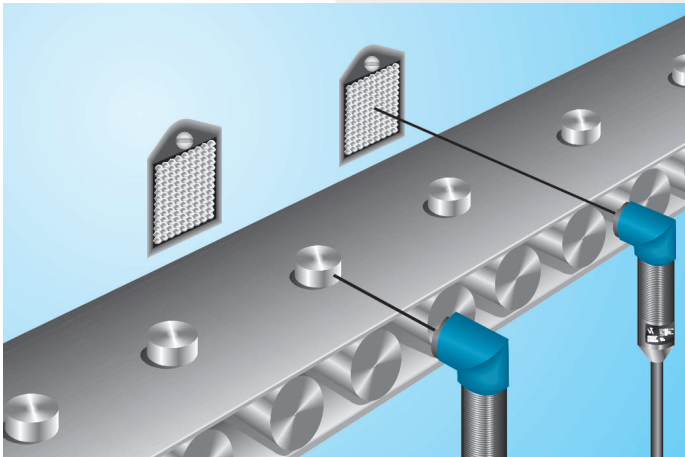

Recognition of smallest parts
Retro Reflective Barrier

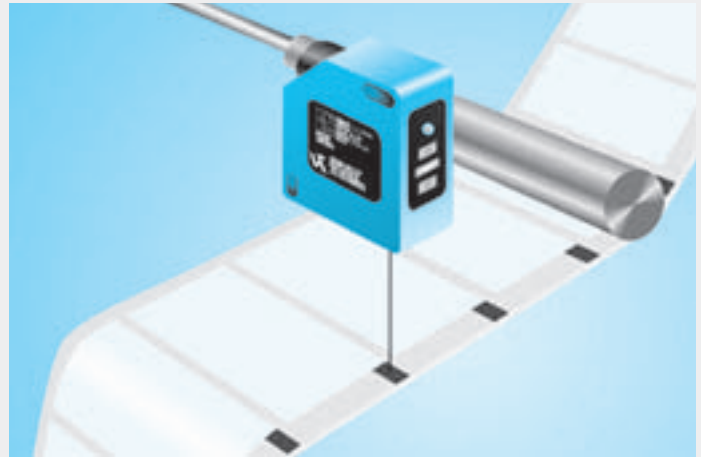

Print- and colour mark detection
Print Mark Sensor