

# Inductive Proximity Switch

flush Housing G 10 x 16 mm

## IG030BK28VD

Part Number

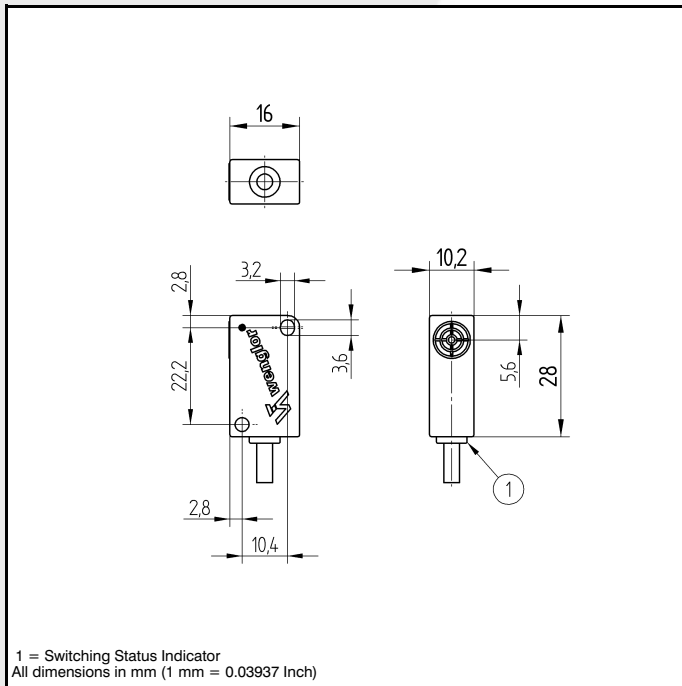

### Technical Data

Inductive Data	
Switching Distance	3 mm
Correction Factors V2A / Brass / Al	0.81/0.50/0.46
Mounting	flush
Switching Hysteresis	< 15 %
Electrical Data	
Supply Voltage	10...30 V DC
Current Consumption (U <sub>b</sub> = 24V)	< 6 mA
Switching Frequency	1 kHz
Temperature Drift	< 10 %
Temperature Range	-25...80 °C
Switching Output Voltage Drop	< 2.5 V
Switching Output/Switching Current	200 mA
Residual Current Switching Output	< 100 µA
Short Circuit Protection	yes
Reverse Polarity Protection	yes
Overload Protection	yes
Mechanical Data	
Housing	Plastic
Full Encapsulation	yes
Protection Mode	IP 67
Connection	Prewired
Cabel Length	2 m
Protective Insulation, Rated Voltage	50 V

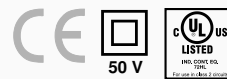

Part Number	<b>IG030BK28VD</b>
	●
Connection Diagram No.	<b>206</b>

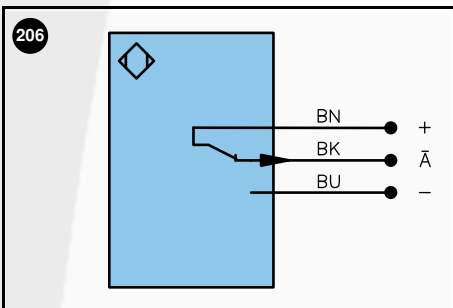

Legend		Wire colors according to DIN IEC 757	
+	Power supply "+"	U	Test input
-	Power supply "0V"	W	Trigger input
~	Power supply (AC Voltage)	O	Analog output (1,2,3...)
A	Switching output (1,2,3...) / NO	O-	Ground for the analog output
Ā	Switching output (1,2,3...) / NC	bz	Block discharge
V	Contamination / Error output (NO)	Aw	Valve output
V	Contamination / Error output (NC)	a	Valve control output "+"
E	Input (analog or digital)	b	Valve control output "0V"
T	Teach input	SY	Synchronization
Z	Time delay (activation)	E+	Receiver-Line
S	Shielding	S+	Emitter-Line
RxD	RS-232 receive path	⊕	Grounding
TxD	RS-232 send path		
		BK	black
		BN	brown
		RD	red
		OG	orange
		YE	yellow
		GN	green
		BU	blue
		VT	violet
		GY	grey
		WH	white
		PK	pink
		GNYE	green yellow

Specifications are subject to change without notice

28/02