

Inductive Proximity Switch

non-flush Housing H 8 x 8 mm

IH030NK41VD

Part Number

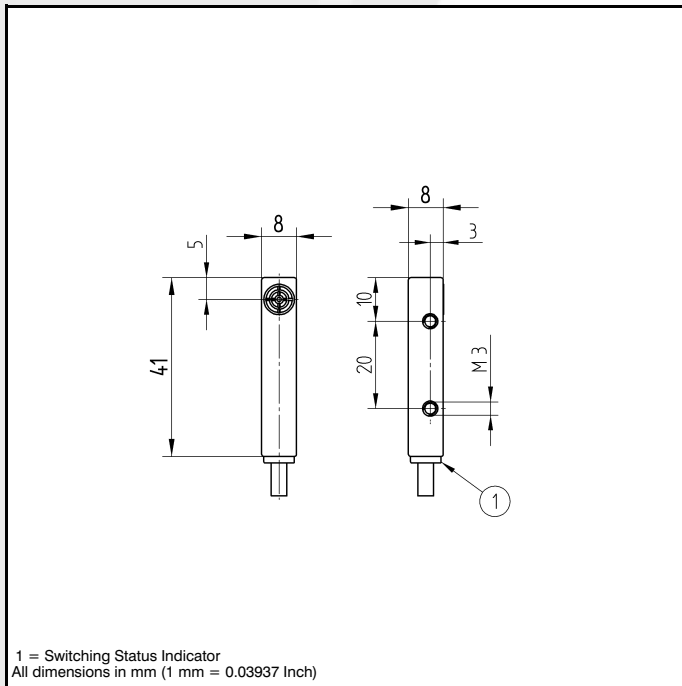

Technical Data

Inductive Data	
Switching Distance	3 mm
Correction Factors V2A / Brass / Al	0.82/0.54/0.48
Mounting	non-flush
Flush mountable in Aluminum	yes
Switching Hysteresis	< 15 %
Electrical Data	
Supply Voltage	10...30 V DC
Current Consumption (U _b = 24V)	< 6 mA
Switching Frequency	1 kHz
Temperature Drift	< 10 %
Temperature Range	-25...80 °C
Switching Output Voltage Drop	< 2.5 V
Switching Output/Switching Current	100 mA
Residual Current Switching Output	< 100 μA
Short Circuit Protection	yes
Reverse Polarity Protection	yes
Overload Protection	yes
Mechanical Data	
Housing	Plastic
Full Encapsulation	yes
Protection Mode	IP 67
Connection	Prewired
Cabel Length	2 m
Protective Insulation, Rated Voltage	50 V

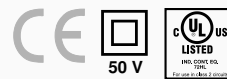

Part Number	IH030NK41VD
	●
Connection Diagram No.	206

PNP NC

Connection Diagram No.

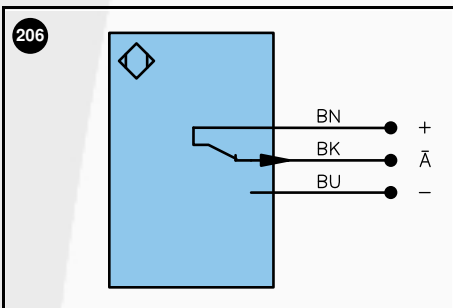

Legend		Wire colors according to DIN IEC 757
+	Power supply "+"	BK black
-	Power supply "0V"	BN brown
~	Power supply (AC Voltage)	RD red
A	Switching output (1,2,3...) / NO	OG orange
Ā	Switching output (1,2,3...) / NC	YE yellow
V	Contamination / Error output (NO)	GN green
V̄	Contamination / Error output (NC)	BU blue
E	Input (analog or digital)	VT violet
T	Teach input	GY grey
Z	Time delay (activation)	WH white
S	Shielding	PK pink
RxD	RS-232 receive path	GNYE green yellow
TxD	RS-232 send path	
U	Test input	
W	Trigger input	
O	Analog output (1,2,3...)	
0-	Ground for the analog output	
BZ	Block discharge	
Aw	Valve output	
a	Valve control output "+"	
b	Valve control output "0V"	
SY	Synchronization	
E+	Receiver-Line	
S+	Emitter-Line	
⊕	Grounding	

Specifications are subject to change without notice