

# Inductive Proximity Switch

flush Housing W M18 x 1

## IW080BM70VA

Part Number

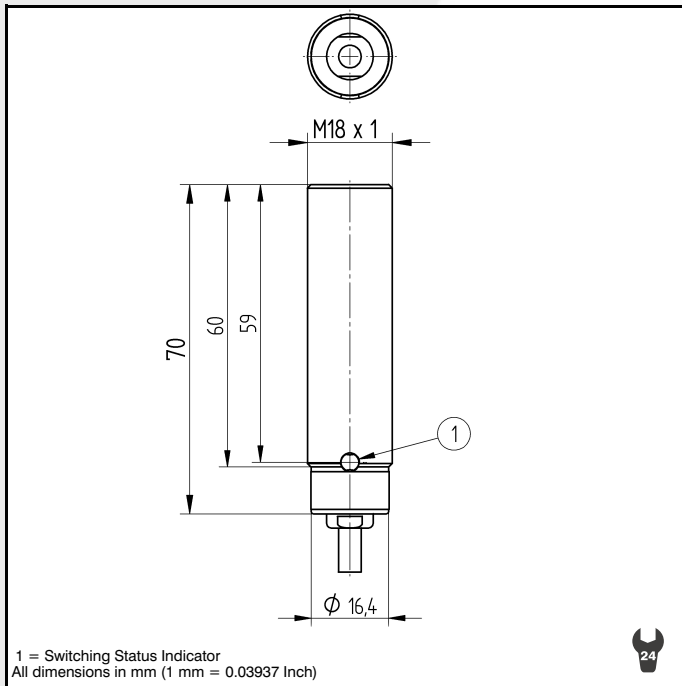

### Technical Data

Inductive Data	
Switching Distance	8 mm
Correction Factors V2A / Brass / Al	0.76/0.42/0.32
Mounting	flush
Switching Hysteresis	< 15 %
Electrical Data	
Supply Voltage	10...30 V DC
Current Consumption (U <sub>b</sub> = 24V)	< 6 mA
Switching Frequency	200 Hz
Temperature Drift	< 10 %
Temperature Range	-25...80 °C
Switching Output Voltage Drop	< 2.5 V
Switching Output/Switching Current	200 mA
Residual Current Switching Output	< 100 µA
Short Circuit Protection	yes
Reverse Polarity Protection	yes
Overload Protection	yes
Mechanical Data	
Housing	BrasNicPlated
Full Encapsulation	yes
Protection Mode	IP 67
Connection	Prewired
Cabel Length	2 m
Protective Insulation, Rated Voltage	50 V

### Preliminary data



Part Number	<b>IW080BM70VA</b>
-------------	--------------------

PNP NO/NC antivalent	●
Connection Diagram No.	201

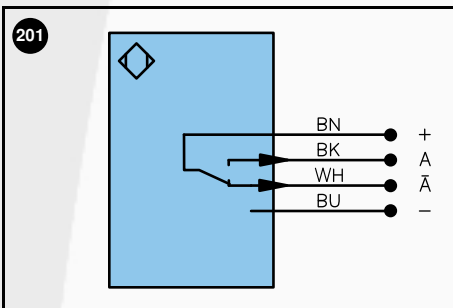

Legend		Wire colors according to DIN IEC 757			
+	Power supply "+"	U	Test input	BK	black
-	Power supply "0V"	W	Trigger input	BN	brown
~	Power supply (AC Voltage)	O	Analog output (1,2,3...)	RD	red
A	Switching output (1,2,3...) / NO	O-	Ground for the analog output	OG	orange
Ā	Switching output (1,2,3...) / NC	bz	Block discharge	YE	yellow
V	Contamination / Error output (NO)	AwV	Valve output	GN	green
V̄	Contamination / Error output (NC)	a	Valve control output "+"	BU	blue
E	Input (analog or digital)	b	Valve control output "0V"	VT	violet
T	Teach input	SY	Synchronization	GY	grey
Z	Time delay (activation)	E+	Receiver-Line	WH	white
S	Shielding	S+	Emitter-Line	PK	pink
RxD	RS-232 receive path	⊕	Grounding	GNYE	green yellow
TxD	RS-232 send path				

Specifications are subject to change without notice