

# Inductive Proximity Switch

non-flush Housing W M18 x 1

## IW120NM55VA

Part Number

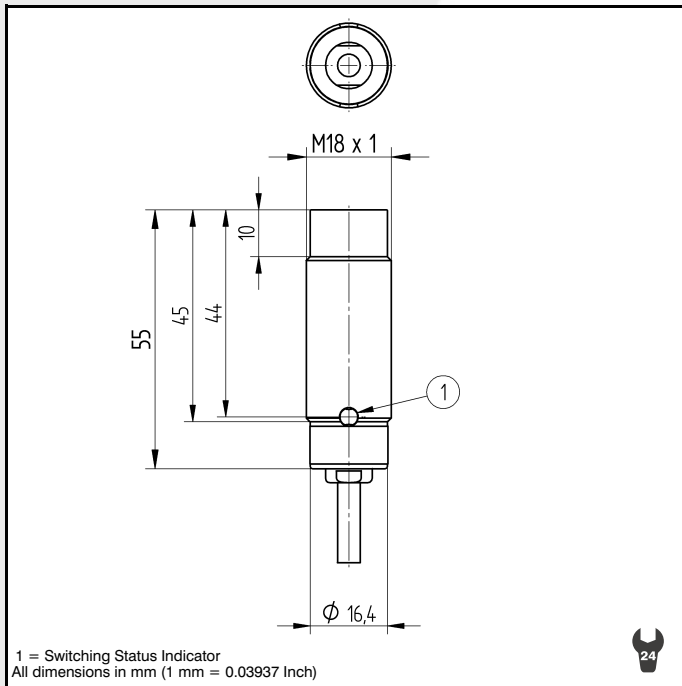

### Technical Data

Inductive Data	
Switching Distance	12 mm
Correction Factors V2A / Brass / Al	0.73/0.50/0.48
Mounting	non-flush
Switching Hysteresis	< 15 %
Electrical Data	
Supply Voltage	10...30 V DC
Current Consumption (U <sub>b</sub> = 24V)	< 6 mA
Switching Frequency	200 Hz
Temperature Drift	< 10 %
Temperature Range	-25...80 °C
Switching Output Voltage Drop	< 2.5 V
Switching Output/Switching Current	200 mA
Residual Current Switching Output	< 100 µA
Short Circuit Protection	yes
Reverse Polarity Protection	yes
Overload Protection	yes
Mechanical Data	
Housing	BrasNicPlated
Full Encapsulation	yes
Protection Mode	IP 67
Connection	Prewired
Cabel Length	2 m
Protective Insulation, Rated Voltage	50 V

### Preliminary data



Part Number	IW120NM55VA
	●
Connection Diagram No.	201

PNP NO/NC antivalent

Connection Diagram No.

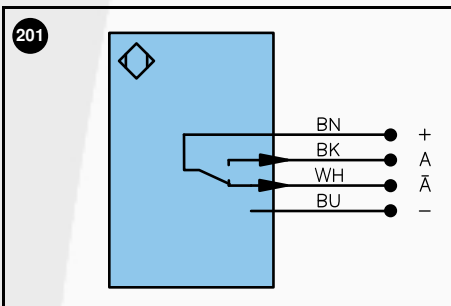

### Legend

+	Power supply "+"	U	Test input
-	Power supply "0V"	W	Trigger input
~	Power supply (AC Voltage)	O	Analog output (1,2,3...)
A	Switching output (1,2,3...) / NO	O-	Ground for the analog output
A̅	Switching output (1,2,3...) / NC	bz	Block discharge
V	Contamination / Error output (NO)	Aw	Valve output
V̅	Contamination / Error output (NC)	a	Valve control output "+"
E	Input (analog or digital)	b	Valve control output "0V"
T	Teach input	SY	Synchronization
Z	Time delay (activation)	E+	Receiver-Line
S	Shielding	S+	Emitter-Line
RxD	RS-232 receive path	⊕	Grounding
TxD	RS-232 send path		

Wire colors according to DIN IEC 757	
BK	black
BN	brown
RD	red
OG	orange
YE	yellow
GN	green
BU	blue
VT	violet
GY	grey
WH	white
PK	pink
GNYE	green yellow

Specifications are subject to change without notice

47/03