

Reflex Sensors

with photodiode line array

LASER

CP70QXVT80

Part Number



- **Highly accurate switching distance**
- **Measured value independent of material, color and brightness**
- **Minimal switching hysteresis**

The sensor uses a high-resolution photodiode line array and DSP technology, virtually eliminating material, colour and brightness related switching point differences. Two independent switching outputs are available, at which two switching thresholds and one on or off-delay time (in 10 ms steps) can be configured. Sensor functions can be activated, and scanning results can be acquired via the RS-232 interface.

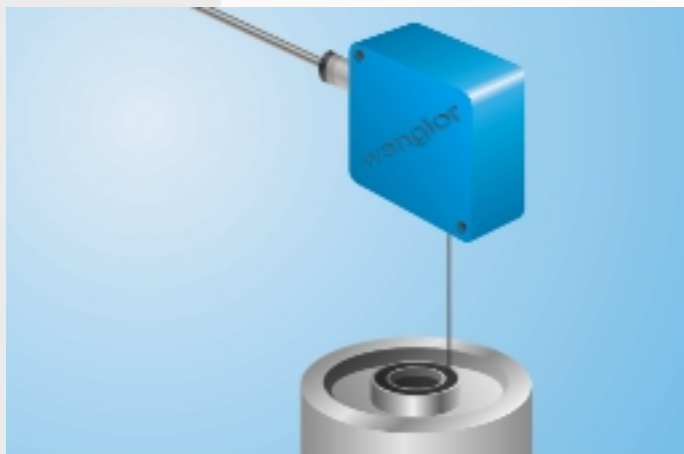

Technical Data

Optical Data	
Working Range	60...660 mm
Switching Hysteresis	< 1 %
Light Source	Laser (red)
Wave Length	655 nm
Service Life (T = +25°C)	100000 h
Laser Protection Class (EN 60825-1)	2
max. Ambient Light	10000 Lux
Light Spot Diameter	see Table 1
Electrical Data	
Supply Voltage	10...30 V DC
Current Consumption (U _b = 24V)	< 50 mA
Switching Frequency	150 Hz
Response Time	< 3300 μs
ON-/OFF-Delay	yes
Time Delay	0...500 ms
Temperature Drift	< 0.15 mm/°C
Temperature Range	-25...60 °C
Switching Outputs	2
Switching Output Voltage Drop	< 1.5 V
Switching Output/Switching Current	200 mA
Short Circuit Protection	yes
Reverse Polarity Protection	yes
Teach Mode	HT,VT,TP
Interface	RS-232
Baud Rate	38400 Bd
Protocol	8 N 1
Mechanical Data	
Adjustment	Teach-In
Housing	Plastic
Protection Mode	IP 67
Connection	M 12x1
Protective Insulation, Rated Voltage	50 V

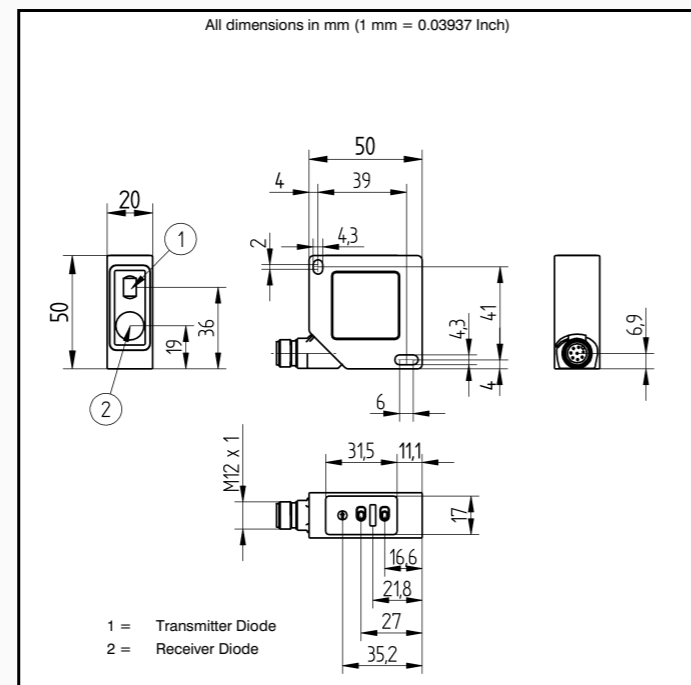

Specifications are subject to change without notice
48/03



Table 1

Working Distance	60 mm	660 mm
Light Spot Size	0,6 x 1,5 mm	3,0 x 8,0 mm

Plug Version	Part Number
CP70QXVT80	CP70QXVT80
Error Output	●
Configurable as PNP/NPN/Push-Pull	●
NO/NC switchable	●
RS-232 Interface	●
Connection Diagram No.	737
Control Panel No.	P 8
Suitable Plug No.	80

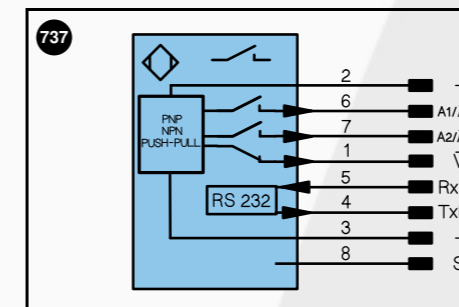

Legend		Wire colors according to DIN IEC 757
+	Power supply "+"	BK black
-	Power supply "0V"	BN brown
~	Power supply (AC Voltage)	RD red
A	Switching output (1,2,3...) / NO	OG orange
Ä	Switching output (1,2,3...) / NC	YE yellow
V	Contamination / Error output (NO)	GN green
V	Contamination / Error output (NC)	BU blue
Aw	Valve output	GN green
a	Valve control output "+"	BU blue
b	Valve control output "0V"	VT violet
T	Teach input	GY grey
E	Input (analog or digital)	WH white
Z	Time delay (activation)	PK pink
S	Shielding	GNYE green yellow
RxD	RS-232 receive path	
TxD	RS-232 send path	
U	Test input	
W	Trigger input	
O	Analog output (1,2,3...)	
O-	Ground for the analog output	
BZ	Block discharge	
Aw	Valve output	
a	Valve control output "+"	
b	Valve control output "0V"	
SY	Synchronization	
E+	Receiver-Line	
S+	Emitter-Line	
⊕	Grounding	

Accessories

- Mounting Bracket WP
- Serial Interface Adapter S232W2

Ctrl. Panel

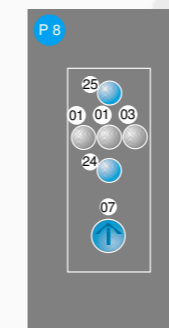

- 01 = Switching Status Indicator
- 03 = Error Indicator
- 07 = Selector Switch
- 24 = Plus Button
- 25 = Minus Button