

# Reflex Sensors

with Background Suppression

## HN33PA

Part Number



- Precision Background Suppression
- Red Light



### Technical Data

Optical Data	
Range	300 mm
Switching Hysteresis	< 5 %
Light Source	Red Light
Service Life (T = +25°C)	100000 h
max. Ambient Light	10000 Lux
Light Spot Diameter	see Table 1
Electrical Data	
Supply Voltage	10...30 V DC
Current Consumption (U <sub>b</sub> = 24V)	30 mA
Switching Frequency	800 Hz
Response Time	2 ms
Temperature Drift	< 10 %
Temperature Range	-25...60 °C
Switching Output Voltage Drop	< 2.5 V
PNP Switching Output/Switching Current	200 mA
Short Circuit Protection	yes
Reverse Polarity Protection	yes
Overload Protection	yes
Mechanical Data	
Housing	Plastic
Protection Mode	IP 67
Connection	Prewired
Cabel Length	2 m
Protective Insulation, Rated Voltage	50 V



Table 1

Range	60 mm	150 mm	300 mm
Light Spot Diameter	8 mm	15 mm	20 mm

	Prewired Version
Part Number	HN33PA
PNP NO/NC antivalent	●
Connection Diagram No.	201
Control Panel No.	N 3

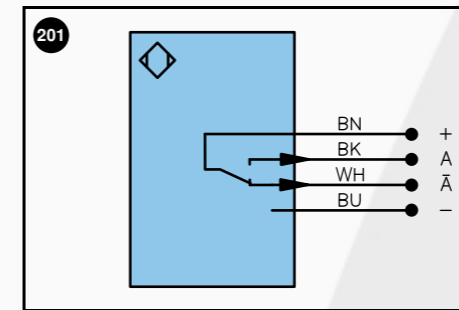

Legend		Wire colors according to DIN IEC 757
+	Power supply "+"	BK black
-	Power supply "0V"	BN brown
-	Power supply (AC Voltage)	RD red
A	Switching output (1,2,3...) / NO	OG orange
A̅	Switching output (1,2,3...) / NC	YE yellow
V	Contamination / Error output (NO)	GN green
V̅	Contamination / Error output (NC)	BU blue
E	Input (analog or digital)	VT violet
T	Teach input	GY grey
Z	Time delay (activation)	WH white
S	Shielding	PK pink
RxD	RS-232 receive path	GNVE green yellow
TxD	RS-232 send path	
U	Test input	
W	Trigger input	
O	Analog output (1,2,3...)	
O-	Ground for the analog output	
BZ	Block discharge	
Aw	Valve output	
a	Valve control output "+"	
b	Valve control output "0V"	
SY	Synchronization	
E+	Receiver-Line	
S+	Emitter-Line	
≡	Grounding	

These sensors are particularly well suited for recognizing objects in front of any type of background. The color, shape and surface characteristics of the object have practically no influence on sensor switching performance.

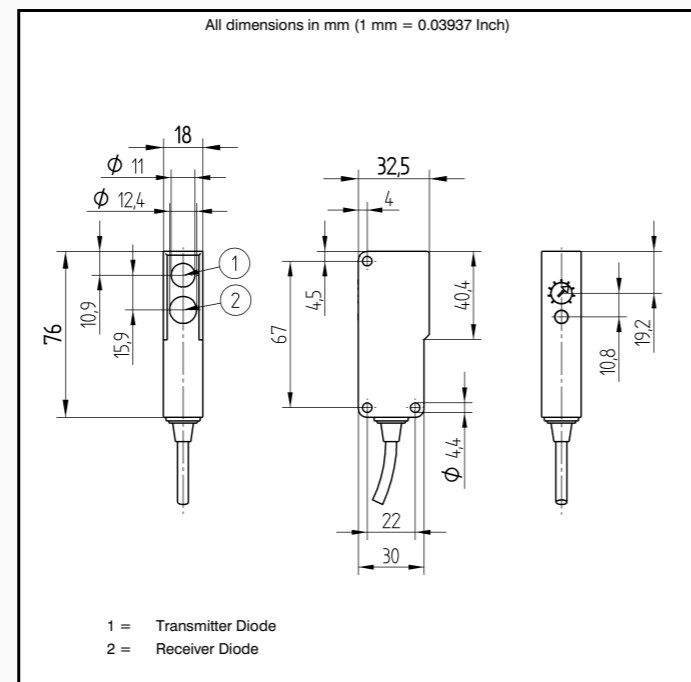
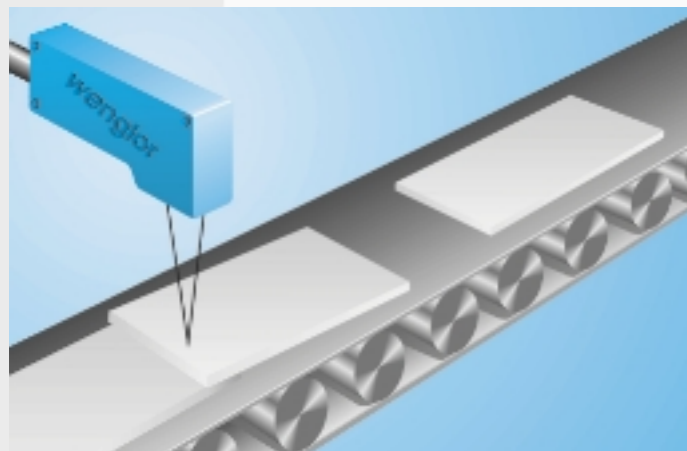

### Accessories

Mounting Bracket WN

### Ctrl. Panel



- 05 = Switching Distance Adjuster
- 30 = Switching Status/Contamination Warning

### Switching Distance Deviation

Typical characteristic curve based on Kodak white, 90%

