

# Retro-Reflex Sensors

for Clear Glass Recognition

## KN88PA

Part Number



- Recognition of Clear Glass
- Recognition of PET bottles
- Sheet products



### Technical Data

Optical Data	
Range	2600 mm
Reference Reflector	RQ100BA
Clear Glass Recognition	yes
Switching Hysteresis	< 5 %
Light Source	Red Light
Polarization Filter	yes
Service Life (T = +25°C)	100000 h
max. Ambient Light	10000 Lux
Opening Angle	3 °
Electrical Data	
Supply Voltage	10...30 V DC
Current Consumption (U <sub>b</sub> = 24V)	< 40 mA
Switching Frequency	2500 Hz
Response Time	200 μs
Temperature Drift	< 3 %
Temperature Range	-10...60 °C
Switching Output Voltage Drop	< 2.5 V
PNP Switching Output/Switching Current	200 mA
Residual Current Switching Output	< 50 μA
Short Circuit Protection	yes
Reverse Polarity Protection	yes
Overload Protection	yes
Mechanical Data	
Housing	Plastic
Full Encapsulation	yes
Protection Mode	IP 67
Connection	Prewired
Cabel Length	2 m
Protective Insulation, Rated Voltage	50 V



Prewired Version	
Part Number	KN88PA
PNP NO/NC antivalent	●
Connection Diagram No.	201
Control Panel No.	N 1 No1

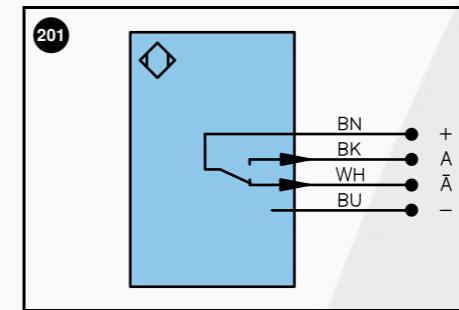

Legend		
+	Power supply "+"	U Test input
-	Power supply "0V"	W Trigger input
-	Power supply (AC Voltage)	O Analog output (1,2,3,...)
A	Switching output (1,2,3...) / NO	O- Ground for the analog output
A-bar	Switching output (1,2,3...) / NC	BZ Block discharge
V	Contamination / Error output (NO)	Aw Valve output
V-bar	Contamination / Error output (NC)	a Valve control output "+"
E	Input (analog or digital)	b Valve control output "0V"
T	Teach input	SY Synchronization
Z	Time delay (activation)	E+ Receiver-Line
S	Shielding	S+ Emitter-Line
RxD	RS-232 receive path	≡ Grounding
TxD	RS-232 send path	

Wire colors according to DIN IEC 757	
BK	black
BN	brown
RD	red
OG	orange
YE	yellow
GN	green
BU	blue
VT	violet
GY	grey
WH	white
PK	pink
GNYE	green yellow

A reflector must be used in combination with these sensors. wenglor has the right retro-reflex light barrier for every application. Even crystal-clear objects and sheet products can be reliably recognized.

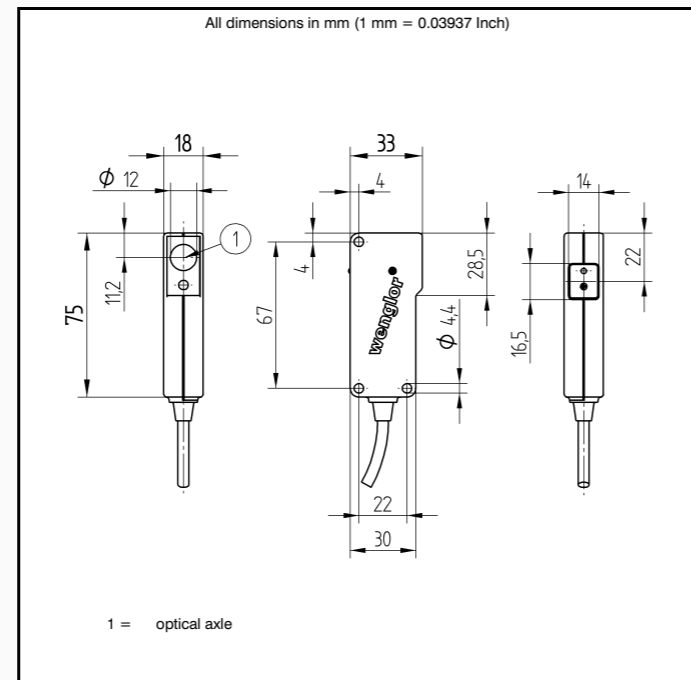
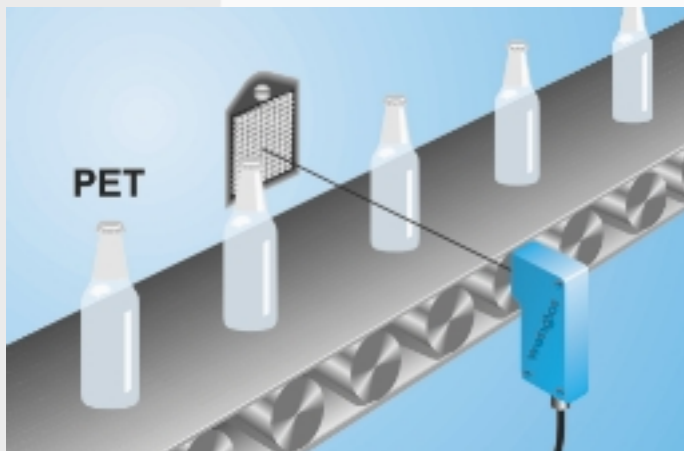

### Accessories

- Mounting Bracket WN
- Reflector, Reflector Tape

### Ctrl.Panel Optic

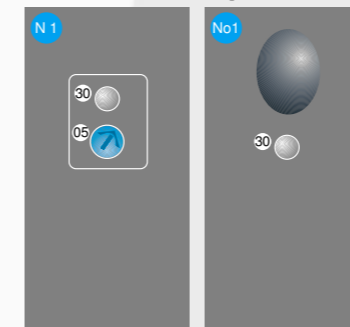

- 05 = Switching Distance Adjuster
- 30 = Switching Status/Contamination Warning