

Retro-Reflex Sensors

for Clear Glass Recognition

KN88PA3

Part Number



- Recognition of Clear Glass
- Recognition of PET bottles
- Sheet products



Technical Data

Optical Data	
Range	2600 mm
Reference Reflector	RQ100BA
Clear Glass Recognition	yes
Switching Hysteresis	< 5 %
Light Source	Red Light
Polarization Filter	yes
Service Life (T = +25°C)	100000 h
max. Ambient Light	10000 Lux
Opening Angle	3 °
Electrical Data	
Supply Voltage	10...30 V DC
Current Consumption (U _b = 24V)	< 40 mA
Switching Frequency	2500 Hz
Response Time	200 μs
Temperature Drift	< 3 %
Temperature Range	-10...60 °C
Switching Output Voltage Drop	< 2.5 V
PNP Switching Output/Switching Current	200 mA
Residual Current Switching Output	< 50 μA
Short Circuit Protection	yes
Reverse Polarity Protection	yes
Overload Protection	yes
Mechanical Data	
Housing	Plastic
Full Encapsulation	yes
Protection Mode	IP 67
Connection	M 12x1
Protective Insulation, Rated Voltage	50 V



Plug Version	
Part Number	KN88PA3
PNP NO/NC antivalent	●
Connection Diagram No.	101
Control Panel No.	N 1 No 1
Suitable Plug No.	1

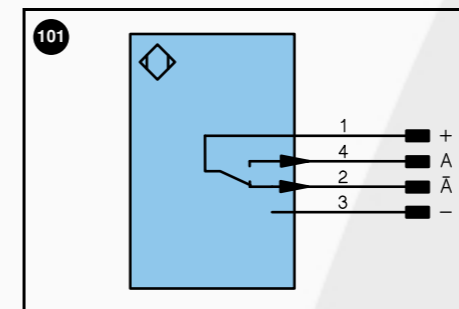

Legend				
+	Power supply "+"	U	Test input	Wire colors according to DIN IEC 757
-	Power supply "0V"	W	Trigger input	BK black
-	Power supply (AC Voltage)	O	Analog output (1,2,3,...)	BN brown
A	Switching output (1,2,3...)/ NO	O-	Ground for the analog output	RD red
A̅	Switching output (1,2,3...)/ NC	BZ	Block discharge	OG orange
V	Contamination / Error output (NO)	Aw	Valve output	GN green
V̅	Contamination / Error output (NC)	a	Valve control output "+"	BU blue
E	Input (analog or digital)	b	Valve control output "0V"	VT violet
T	Teach input	SY	Synchronization	GY grey
Z	Time delay (activation)	E+	Receiver-Line	WH white
S	Shielding	S+	Emitter-Line	PK pink
RxD	RS-232 receive path	⊕	Grounding	GNYE green yellow
TxD	RS-232 send path			

A reflector must be used in combination with these sensors. wenglor has the right retro-reflex light barrier for every application. Even crystal-clear objects and sheet products can be reliably recognized.

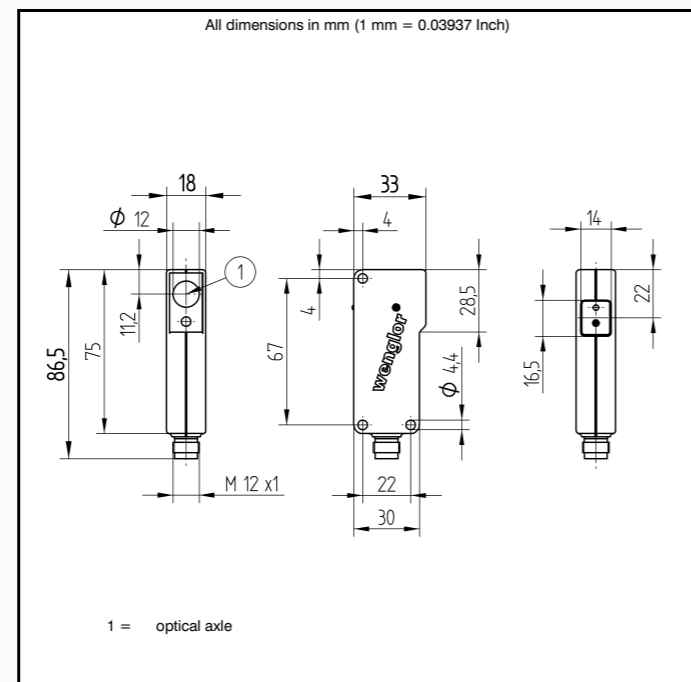
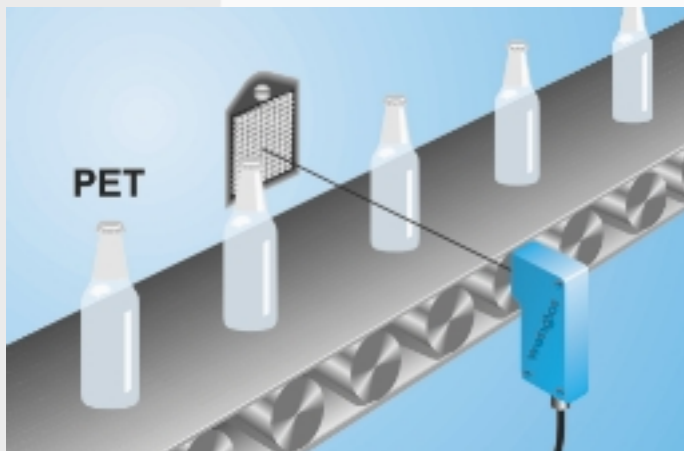

Accessories

- Mounting Bracket WN
- Reflector, Reflector Tape

Ctrl. Panel Optic

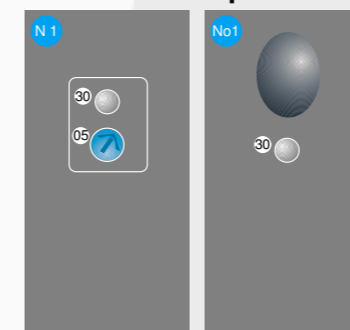

- 05 = Switching Distance Adjuster
- 30 = Switching Status/Contamination Warning