

Retro-Reflex Sensors

for Roller Conveyor Systems

OPT258

Part Number



- Block Discharge can be executed with signal level 24V (I > 1mA)
- Integrated Logic
- Large Working Range
- Recognition of high-gloss and jet black objects

These sensors have been specially designed for use in accumulation roller conveyors. Their compact design allows for installation between rollers below the transport level. They are thus protected against mechanical damage.

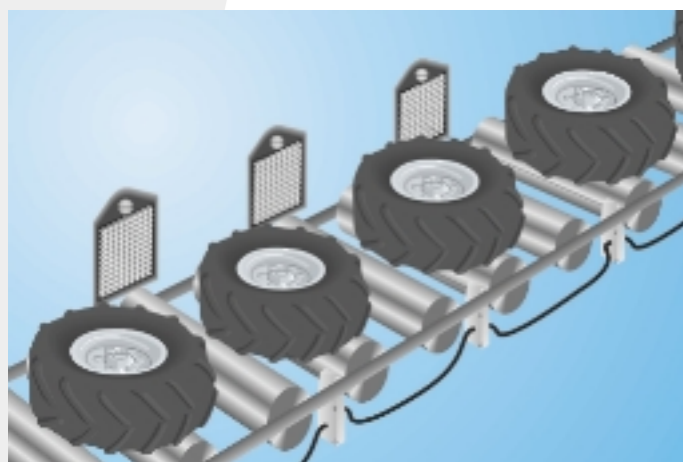

Technical Data

Optical Data	
Range	6500 mm
Reference Reflector/Reflex Foil	RQ100BA
max. Distance on Reflector	100 mm
Switching Hysteresis	< 15 %
Light Source	Red Light
Polarization Filter	yes
Service Life (T = +25°C)	100000 h
max. Ambient Light	10000 Lux
Opening Angle	5 °
Electrical Data	
Supply Voltage	18...30 V DC
Current Consumption Sensor (U _b = 24V)	< 25 mA
Switching Frequency	100 Hz
Response Time	5 ms
Temperature Drift	< 10 %
Temperature Range	-15...50 °C
Switching Outputs	1
Switching Output Voltage Drop	< 0.8 V
PNP Switching Output/Switching Current	200 mA
Short Circuit Protection	yes
Reverse Polarity Protection	yes
Overload Protection	yes
Logic	yes
Block Discharge	yes
Valve Control	yes
Mechanical Data	
Housing	Plastic
Full Encapsulation	yes
Protection Mode	IP 65
Connection	M12 x 1
Cabel Length	100 cm

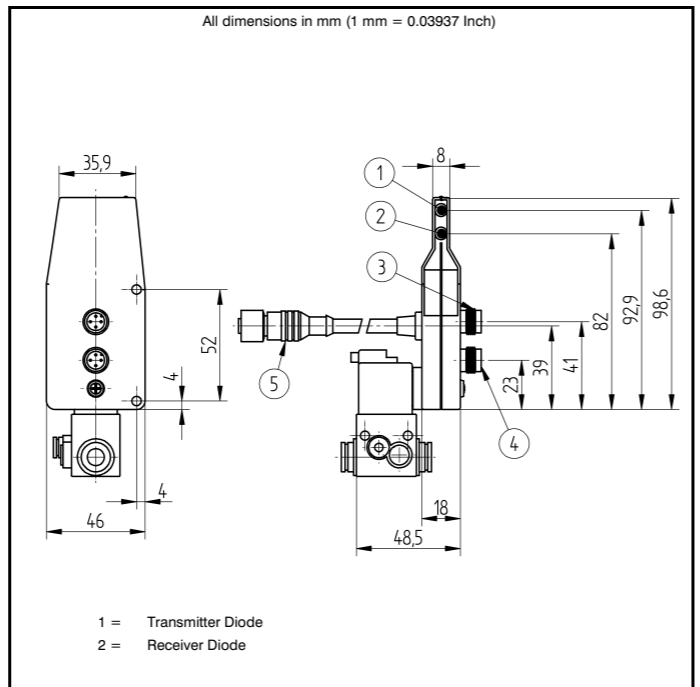

Specifications are subject to change without notice
28/06

Part Number	Plug Version
OPT258	
PNP NO	●
Connection Diagram No.	735
Control Panel No.	OP2
Suitable Plug No.	2 2a
Pneumatic Solenoid Valve Unit	
Valve no.	K04
Supply Voltage Valve	19.2...28.8 V
Current Consumption Valve	86 mA
Operating Pressure	0.5...7 bar
Nominal Width	0.8 mm
Nominal flow rate 1 -> 2	20 NL/min
Nominal flow rate 2 -> 3	100 NL/min
Supply line connector pipe	2x 8x1
Working line connector pipe	4x1
Valve function	3/2-Way
Switching function	NC

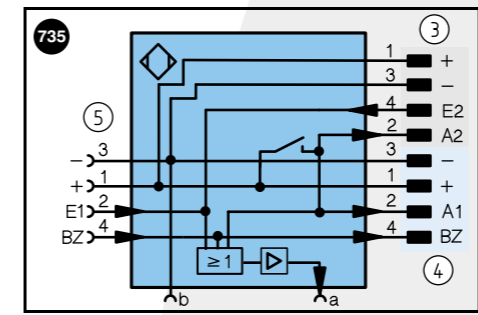

Legend		Wire colors according to DIN IEC 757
+	Power supply "+"	BK black
-	Power supply "0V"	BN brown
-	Power supply (AC Voltage)	RD red
A	Switching output (1,2,3...) / NO	OG orange
A	Switching output (1,2,3...) / NC	YE yellow
V	Contamination / Error output (NC)	GN green
V	Contamination / Error output (NC)	BU blue
E	Input (analog or digital)	VT violet
T	Teach input	GY grey
Z	Time delay (activation)	WH white
S	Shielding	PK pink
ReD	RS-232 receive path	GNVE green yellow
TxD	RS-232 send path	
RDY	Ready	
GND	Ground	
CL	Clock	
U	Test input	
W	Trigger input	
O	Analog output (1,2,3...)	
O-	Ground for the analog output	
BZ	Block discharge	
Aw	Valve output	
a	Valve control output "+"	
b	Valve control output "0V"	
SY	Synchronization	
E+	Receiver-Line	
S+	Emitter-Line	
±	Grounding	
SrR	Switching Distance Reduction	
USB+	USB data +	
USB-	USB data -	
Ba	Interfaces-Bus A(+)/B(-)	
La	Emitted light disengageable	

Accessories

- Reflector, Reflector Sheet
- Adapter OPT 70N, 70S, 70S+

Ctrl.Panel



01 = Switching Status Indicator

Feasible reflector distance

Reflektor type, mounting distance			
RQ100BA	0.25...6.5 m	RF255	0.15...1.5 m
RE18040BA	0.1...4 m	RF508	0.15...1.9 m
RQ84BA	0.25...5 m	RF258	0.15...1.5 m
RR84BA	0.2...5 m		
RE9538BA	0.15...2 m		
RR50_A	0.15...3 m		
RE6040BR	0.2...2.5 m		
RE8222BA	0.25...1.8 m		
RE6151BH	0.65...2 m		
RF505	0.15...1.9 m		