

Technical Data Sheet

Stand Alone Pyrometer Series *Metis MY80, MY81* and *MY84* for common applications

Pyrometer Series *Metis MY80, MY81* and *MY84* using pyroelectrical detectors and operating in a long wave band area between 8 and 14 μm . They were developed especially to measure small spot sizes at lower temperatures with fast exhibition times.

The pyrometer model *Metis MY 84* is ideally suited to all types of applications like measurement of organic materials, painted metal surfaces, rubber, paper, textiles and thicker plastics.

Model *Metis MY81* with spectral response between 8 and 10 μm can be used for similar applications like *Metis MY 84*. It offers however the advantage of using calcium fluoride as lens or window material which is easier to handle than the zinc sulphide material used for *Metis MY84* ser. We recommend using this model also for all kind of applications where the Scanners SC10 SC11 or SC12 are necessary. The only disadvantage is the somewhat bigger spot size diameter at the same distance.

For non contact temperature measurement of thin polyester films and all kind of fluorocarbon-plastics the narrow band model *Metis MY80* was developed. Further more it is best choice to measure thin glass surfaces in furnaces because glass is neither transparent nor reflective at 8,05 μm . It meets therefore the so called black body conditions of an ideal radiator.



| Model | MY80 | MY81 | MY84 |
|--------------------------|--------------------|----------------------|--------------------------------------|
| Spectral Response | 8,05 μm | 8 – 10 μm | 8 – 14 μm |
| Temperature-Range | 50 – 400°C | 0 – 400°C | 0 – 400°C 0 – 700°C 0 – 1000°C |

Chart 1. Temperature ranges of each model

Lenses: The infrared energy radiated by the target is centered via focusable or fixed focus lenses directly on the detector. The focussing feature allows control of the cone of vision and offers the possibility to measure either a small spot (focused) or the average of a bigger spot (out of focus). Fixed focus lenses with larger diameter collect more infrared energy and therefore result in smaller spot sizes. The lenses are made of calcium fluoride CaF_2 (*MY80* and *MY81*) or zinc sulphide ZnS (*MY84*). If additional windows are necessary they must offer similar optical characteristics.

Chart 2: Focusable Lenses *Metis MY81*.

| Lens | Distance | Spot Size Diameter | |
|---------|----------|--------------------|--------|
| | | 5 ms or 30 ms | 100 ms |
| OM81-A0 | 110 mm | 1.7 mm | 1.2 mm |
| | 150 mm | 2.7 mm | 1.8 mm |
| | 200 mm | 4.8 mm | 2.8 mm |
| OM81-B0 | 190 mm | 3.1 mm | 2.5 mm |
| | 350 mm | 6.4 mm | 4.3 mm |
| | 680 mm | 14 mm | 10 mm |

Chart 3: Focusable Lenses *Metis MY84*

| Lens | Distance | Spot Size Diameter | |
|---------|----------|--------------------|--------|
| | | 5 ms oder 30 ms | 100 ms |
| OM84-A0 | 112 mm | 1.5 mm | 0.9 mm |
| | 150 mm | 2.5 mm | 1.6 mm |
| | 210 mm | 4.5 mm | 2.6 mm |
| OM84-B0 | 200 mm | 3 mm | 1.8 mm |
| | 800 mm | 14 mm | 7.2 mm |
| | 1400 mm | 26 mm | 15 mm |

Chart 4: Focusable Lens *MY80* (100 ms only)

| Lens | Distance | Spot Size Diameter |
|---------|----------|--------------------|
| OM80-A0 | 115 mm | 2.5 mm |
| | 150 mm | 3.7 mm |
| | 200 mm | 4.8 mm |
| | 250 mm | 6.0 mm |

Chart 5: 3 different Fixed-Focus Lenses *Metis MY81*

| Lens | Distance | Spot Size Diameter | |
|---------|----------|--------------------|--------|
| | | 5 ms or 30 ms | 100 ms |
| OM81-0C | 230 mm | 2.3 mm | 1.5 mm |
| OM81-0D | 370 mm | 3.4 mm | 2.0 mm |
| OM81-0E | 1200 mm | 11 mm | 7.0 mm |

The detector is sensitive to infrared radiation in an area called the **cone of vision**. For the spot size diameter of the cone of vision at shortest, medium and widest focal distances, please see **Chart 2, 3** and **4**. For full scale temperatures up to 700°C the cone of vision diameter in front of the lens is about 16 mm and about 8 mm for full scale temperature of 1000°C. This area has to be kept free from any intervening objects. The spot size diameter for distances not given in the chart can be calculated by interpolation.

Each temperature range of *MY81* and *MY84* are available as well with different fast exposition times of 5, 30, or 100 ms. Slower models offer better optical resolution (smaller spot size). To achieve effectively the best optical resolution of 170:1, with 100 ms exhibition time, the *Metis MY81* can be supplied with fixed focus lenses also. For the spot size diameter of the 3 different fixed focus lenses available with *MY81* ser., please see **Chart 5**

Optical Alignment: *Metis MY* Pyrometers are available with 2 different solutions for aiming the sensor onto the target. The first and most popular method is the built-in laser pointer which is also helpful for focusing. The second solution is a sight-through optics version with reticle-defined target which is advantageous for applications like measurement into furnaces where the laser is not visible from the outside of the furnace.

Temperature Output Signals: *Metis* Pyrometers offer a variety of analog and digital output signals for displaying, recording, archiving and controlling of measured process temperatures. The isolated analog output is selectable from 0 to 4 – 20 mA. Zero- and full-scale temperatures are adjustable to cover any portion of the instrument's available temperature span to a minimum of 50°C.

There is a choice of 2 digital communication interfaces: **RS 232** or **RS 485** max. 19.2 kBd.

Signal Filtering: For measuring and holding of the highest instantaneous temperature value a **peak picker** (maximum value storage) is installed to compensate interruptions or attenuations in radiation caused by bursts of steam, smoke or dust. It can be reset either automatically or manually by an external contact closure or periodically by user preset clear time. In the last case the highest temperature will be held in a dual storage and will be reset in only one of the two storages after preset clear time to avoid a decrease of the temperature output, should a short cold period appear just at the reset moment.

The **exposition time** is the length of time it takes for the output signal to reach 90% of a step change in measured temperature. It can be used to filter out rapid variations in temperature and achieve a "more quiet" signal for control or display purposes.

Software: The **SensorWin Software** is available for automatic or manual set up of the pyrometer, for recording and for saving of graphical or table files. At the same time these files can be used for quality assurance purposes because the parameter settings are recorded, too.

Minimum computer requirements: 500 MHz clock frequency and Windows 95, 98, ME or XP operating system.

Additional Specifications

| | |
|----------------------------|--|
| Measurement Uncertainty: | 1°C + 0.5% of difference between measured and housing temp. ($T_A = 23^\circ\text{C}$, $\epsilon = 1$, $t_{90} = 10\text{ s}$) |
| Repeatability: | 0.1% of measured temperature in °C + 0.2°C ($T_A = 23^\circ\text{C}$, $\epsilon = 1$, $t_{90} = 10\text{ s}$) |
| Exposition Time t_{90} : | <i>MY81 und 84</i> : 5 ms, 30 ms or 100 ms adjustable up to 10 s. <i>MY80</i> : only 100 ms – 10 s |
| Spot Size Diameter | <i>Metis MY80</i> , see chart 4; <i>Metis MY81</i> and <i>MY84</i> see chart 2, 3 and 5 |
| Analog Output Signal: | 0 or 4 – 20 mA selectable, max. load 500 Ω |
| Emissivity Range: | 0.40 – 1.00 |
| Temperature Resolution: | analog: < 0.1% of adjusted temperature range, digital 0.1°C |
| Ambient Temperature: | Pyrometer: operation 0 – 70°C, storage -20 – 80°C |
| Power Supply: | 24 V AC/DC (12 – 30 V AC/DC), AC: 48 – 62 Hz, max. 2 VA |
| Isolation: | power supply, analog and digital output are galvanically isolated against each other and against housing |
| Housing and Rating: | extruded aluminium profile, IP 65 per DIN 40 050 |
| Weight: | 500 g |
| CE Label: | according to EU directives for electromagnetic immunity |
| Laser Pointer: | (optional) 650 nm, < 1 mW, class II per IEC 60825-1-3-4 |

Dimensions: *Metis* with Focussable Lens and Swivel Base HA20

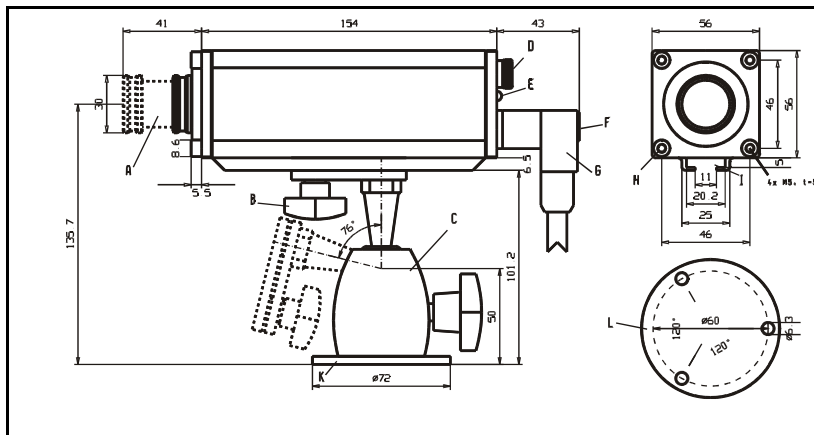

- A: Focussable Lens
- B: Fast-Mount Screw
- C: Swivel Mounting Base
- D: Eye Piece (sight-through optics)
- E: Operation LED
- F: Laser Push Button
- G: 12-pin Connector
- H: Front-Mount Threads
- I: Mounting Rail
- K: Swivel Base Mounting Flange
- L: Base View of item K with Mounting Holes
- M: Mounting Bracket

Water Cooling Jacket KG10 and Air Purge BL12 for use of *Metis* MY in hot ambient up to 200°C



For additional accessories for mounting and protecting of *Metis* Pyrometers, please see back page of *Metis* brochure.

***Metis* MY81 with Fixed Focus Lens and Mounting Bracket HA10**

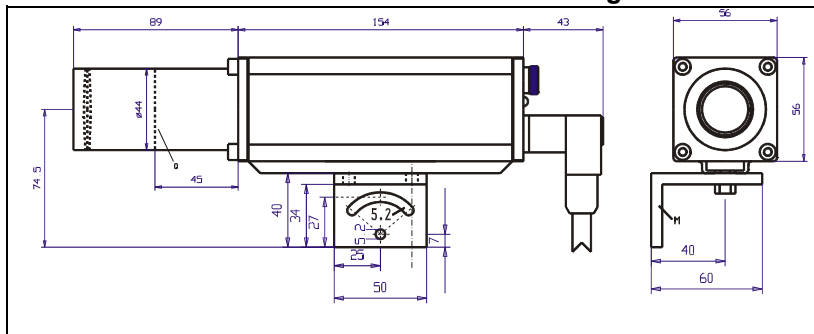

Length of standard lens tube is 89 mm.

Sensortherm GmbH
 Infrared Measurement- and Control-Systems
 In der Schildwacht 13
 65933 Frankfurt/M
 Tel.: +49-0700/73676784
 Fax: +49-069/38996829
info@sensortherm.de
www.sensortherm.com

Specifications are subject to be changed without notice.
 DB_MY80_81_84_en_07.02.15