

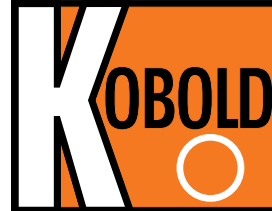

KOBO-LF

Inductive Conductivity Measuring System
Model ACI-Z



measuring
•
monitoring
•
analysing

COMPACT-LINE



- Compact inductive conductivity measuring system
- Measuring range to 1000 mS/cm
- Almost maintenance free conductivity measurement
- Insulated, hermetically sealed PVDF sensor (for most difficult media)
- Integrated Pt 100 for temperature measurement and compensation
- Operating temperature to maximum 120 °C (short-time to 140 °C)
- Operating pressure max. 10 bar
- 2 current outputs (for conductivity and temperature)
- Secure and long-term stable pipe union DN 50 (DIN 11851), Stainless Steel V2A 1.4301
- High electromagnetic compatibility



KOBOLD offices exist in the following countries:

ARGENTINA, AUSTRIA, BELGIUM, BRAZIL, CANADA, CHINA, FRANCE, GERMANY, GREAT BRITAIN, ITALY, NETHERLANDS, POLAND, PERU, SWITZERLAND, USA, VENEZUELA

KOBOLD Messing GmbH
Nordring 22-24
D-65719 Hofheim/Ts.
☎ (06192) 299-0
Fax (06192) 23398
E-mail: info.de@kobold.com
Internet: www.kobold.com

Model:
ACI-Z

Discription

The inductive conductivity transmitter model ACI-Z serves to measure the specific conductivity in liquid media.

It is especially recommended for use in media in which large-scale deposits of particles of dirt, oils, greases; or where gypsum and calcium precipitations are to be expected.

Specific conductivity can be recorded almost maintenance-free by this inductive method of measurement in even the most difficult media. In contrast with the conductive method of measurement, problems such as electrode decomposition and polarization do not occur.

The transmitter has been designed for service in the field. A ruggedized housing of glass-fibre-reinforced polyamide protects the electronics and electrical connections against aggressive environmental influences (protection IP 65).

The device has a three-wire transmitter for conductivity and a two-wire transmitter for temperature (output signals 4–20 mA)

Normally the temperature effect must be compensated because the conductivity depends largely on the temperature of the medium. The measuring instrument is fitted with a temperature detector (Pt 100) and compensator. A temperature coefficient can be set in the range 0-3%/K by a scaled potentiometer.

The measuring cell comprises a hermetically sealed PVDF body in which two measuring coils are arranged. Holes in the measuring cell allow the measured medium to flow through. The measuring cell is to a large extent stable with respect to temperature and pressure. Due to the measuring system, measured medium and signal output are separated electrically.

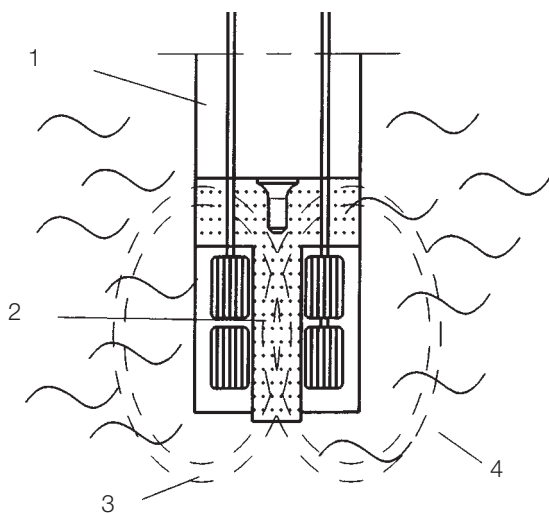

Schematic of construction of inductive measuring cell

- 1 PVDF body
- 2 T-shaped flow channel
- 3 Fluid loop
- 4 Measured medium

Application examples for inductive conductivity measurements

- Food, drinks and pharmaceuticals industry
- Product monitoring (phase separation product/product mix/water)
- Control of cleaning processes (e. g. phase separation cleaning agent/rinsing water)
- Concentration regulation of acids and alcalines (e. g. in electroplating plants or in the process chemical industry)
- Service in CIP plants
- Water and sewage technology
- Batching of chemicals
- Leakage indication in isolated circuits (e. g. heating and cooling plants)

Technical Details

| | |
|---------------------------|---|
| Power supply: | 22...30 V _{DC} ; nominal 24 V _{DC} |
| Electrical connection: | pluggable screw-type terminals |
| Ambient temp.: | -5...+70 °C |
| Protection: | IP 65 |
| Housing: | glass-fibre-reinforced polyamide 2 conduit thread screwings (conduit threads 9 and 11) |
| Weight: | approx. 2 kg |
| Measuring cell materials: | PVDF <i>(Note: temperature, pressure and measured medium influence the service life of the measuring cell)</i> |
| Temp. sensor material: | Pt 100, Stainless Steel 1.4571 |
| Measured medium temp.: | max. 120 °C short-time 140 °C (Sterilization) |
| Pressure: | max. 10 bar |
| Process connection: | pipe screwing DN 50 DIN 11851 |

Installation of measuring system

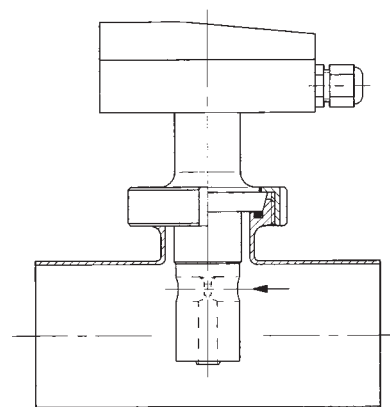

Ideally the measuring system ACI-Z is installed with a T-piece with pipe union nominal width 50 in a pipeline of DN 65 and greater.



Characteristic data for conductivity transmitter

| | |
|-------------------------|---|
| ● Measuring ranges: | Three categories of measuring ranges are available with jumpers. Jumpers can be used internally or floating contacts used externally to switch between these three groups. 0...1/10/100 mS/cm 0...10/100/1000 mS/cm 0...2.5/25/250 mS/cm |
| ● Current output: | three-wire (4...20 mA) |
| ● Current consumption: | max. 120 mA |
| ● Characteristic curve: | Linear |
| ● Accuracy: | ≤ 2% |
| ● max. allowed load: | $R_{Bmax} = \frac{(U_V - 20 V)}{0.02 A}$ R_{Bmax} = maximum allowed burden (Ω) U_V = supply voltage (volt) Example: $U_V = 24V_{DC} \Rightarrow R_{Bmax} = 200 \Omega$ |

Characteristic data for temperature transmitter

| | |
|--------------------------------|---|
| ● Temperature measuring range: | 0...150°C |
| ● Current output: | Two-wire (4...20 mA) |
| ● Current consumption: | max. 40 mA |
| ● Characteristic curve: | Linear |
| ● Accuracy: | ≤ 2% |
| ● max. allowed load: | $R_{Bmax} = \frac{(U_V - 20 V)}{0.02 A}$ R_{Bmax} = maximum allowed burden (Ω) U_V = supply voltage (volt) Example: $U_V = 24V_{DC} \Rightarrow R_{Bmax} = 200 \Omega$ |

Temperature compensation

| | |
|----------------------------|---|
| ● Reference temperature: | 25°C |
| ● Temperature coefficient: | 1 x 0...3%/K adjustable or 4 x 0...3%/K adjustable and can be assigned with non-floating voltage |
| ● Compensation range: | 0...100°C |

Dimensions

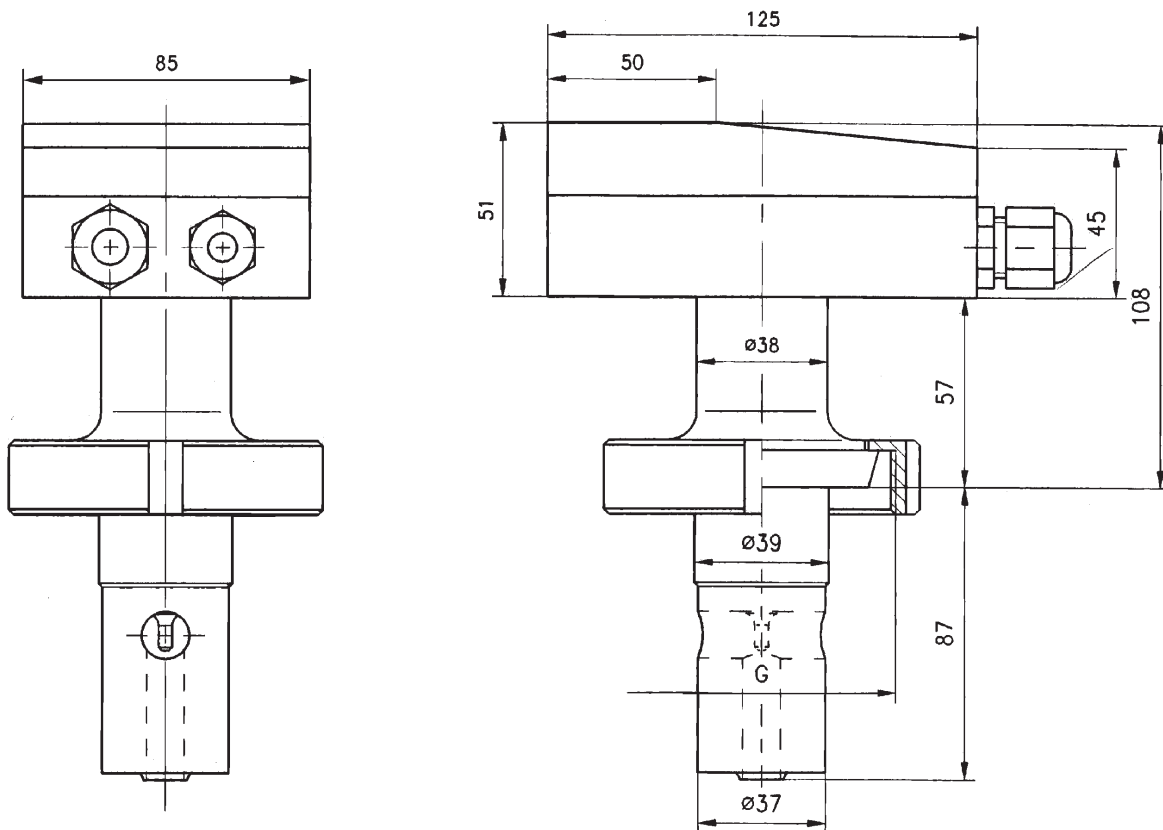

Type codes

