



## Level Sensors Reed Contact Chain



measuring  
•  
monitoring  
•  
analysing



- Measuring length:  
max. 6000 mm
- Measuring accuracy:  
0.5 % for L = 3000 mm
- Pressure: max. 20 bar
- Temperature: max. 130 °C
- Connection: G 3/8 to G 2  
flange: DN 50 to DN 100
- Material: stainless steel,  
PVC, PP-H, PTFE, PE
- Constant level indication  
regardless of conductivity,  
pressure and temperature
- Transmitter
- Infinitely adjustable  
limit value contacts



KOBOLD companies worldwide:

ARGENTINA, AUSTRIA, BELGIUM, CANADA, CHILE, CHINA, CZECH  
REPUBLIC, FRANCE, GERMANY, GREAT BRITAIN, INDONESIA, ITALY,  
MALAYSIA, MEXICO, NETHERLANDS, PERU, POLAND, SWITZERLAND,  
SINGAPORE, SLOVAKIA, THAILAND, USA, VENEZUELA, VIETNAM

KOBOLD Messring GmbH  
Nordring 22-24  
D-65719 Hofheim/Ts.  
☎ +49(0)6192 299-0  
Fax +49(0)6192 23398  
E-Mail: info.de@kobold.com  
Internet: www.kobold.com

**Model:**  
NM-

### Description

Kobold level sensors are used for continuous level indication and monitoring of all types of liquids. Their simple design with only one moving part, the float, means that they are particularly reliable.

A range of sensors in different materials and designs, and with different connections, are available for measured-value acquisition.

The analogue controllers have an electrical output signal that is switchable from 0 - 20 to 4 - 20 mA, finely adjustable relay contacts for level monitoring or integrated indicating devices for level indication.

Kobold level sensors enable the continuous display and monitoring of liquids without being influenced by conductivity, temperature, pressure or viscosity.

### Function Principle

Similar to the Kobold level float switch, the sensor comprises a measuring tube on which a float, fitted with a magnet, switches the reed contacts mounted in the tube in a non-contacting fashion.

As a modification to the known techniques for level float switches, the measuring tube in the level sensors is equipped with a chain of resistors and a reed contacts.

The float activates the sealed contacts through the wall of the measuring tube in a non-contacting manner, whereby a measuring-circuit voltage proportional to the level is picked off at the resistance measuring chain. This sensing technique is similar to the operation of a sliding contact on a resistance potentiometer.

The voltage sampled from the chain of resistors is transferred to a transmitter which outputs a current signal proportional to the liquid level or, depending on the design, also allows limit values to be monitored.

The transmitter can be mounted in the terminal box or as an external instrument. Local analogue or digital indication can also be provided. To satisfy the requirements for greater measuring and monitoring accuracies, the resistance measuring chain can be supplied in 10 mm (15 mm) increments for lengths up to 2 m, and in 20 mm increments for greater lengths.

### Applications

- Waste water and clarification plants
- Feed and batching tanks
- Chemical tanks
- Drinking water tanks
- Rivers, canals, reservoirs

### Design of sensor

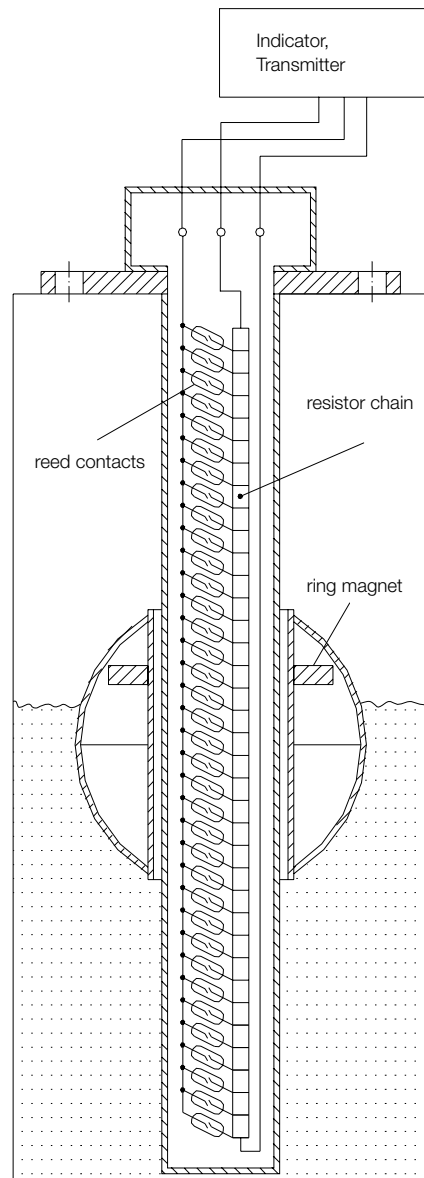

**Technical Details**

Length of measuring tube: min. 300 mm  
 max. 6000 mm  
 Screwed fitting: NM-298...: G 3/8  
 NM-302...: G 1 1/2 or  
 flange DN 50...DN 100 PN 10

**Material**

Measuring tube and  
 screwed fitting: stainless steel 1.4571  
 Float: stainless steel 1.4571, Ø 44 mm  
 Min. density: 0.87 kg/dm<sup>3</sup>  
 Accuracy: 1 % of full scale value  
 Nominal pressure: max. 15 bar or  
 depending on flange design  
 Medium temperature: -20 to +130 °C  
 Total resistance of  
 measuring chain: standard approx. 5000 Ω  
 intrinsically safe  
 approx. 40 000 Ω

Measuring-circuit voltage: max. 24 V<sub>DC</sub>

**Resolution**

NM-298: 15 mm  
 NM-302: 10 mm (ML < 2000 mm)  
 20 mm (ML ≥ 2000 mm)

Number of resistors and  
 sealed contacts at  
 standard matrix 15 mm: 20 pieces per 300 mm  
 measuring chain

Electrical connection: PVC or silicone cable 3-core,  
 length 1 m or special lengths  
 or polyamide connecting box

ATEX-approval: in preparation

**Connecting box with 2-wire transmitter type: -M**

Output: 4 - 20 mA  
 Supply voltage: 16 - 32 V<sub>DC</sub>  
 Load: (U<sub>B</sub> - 9 V) / 0.02 A [Ω]  
 Ambient temperature: max. 70 °C

**Order Details (Example: NM-298 R10 C)**

Mechanical connection	Model	Electrical connection	Resistance
G 3/8	NM-298 R10...	...S =Silicone cable ...Y =special connection	...0=5 kΩ ...E=40 kΩ
G 1 1/2	NM-302 R40...		
Flange DN 50 PN 10	NM-302 F50...	...R =connecting box	
Flange DN 65 PN 10	NM-302 F65...	...M =with transmitter	
Flange DN 80 PN 10	NM-302 F80...	...Y =special connection	
Flange DN 100 PN 10	NM-302 F1H...		

Please specify measuring length "L" and cable length in writing.

**Dimensions**

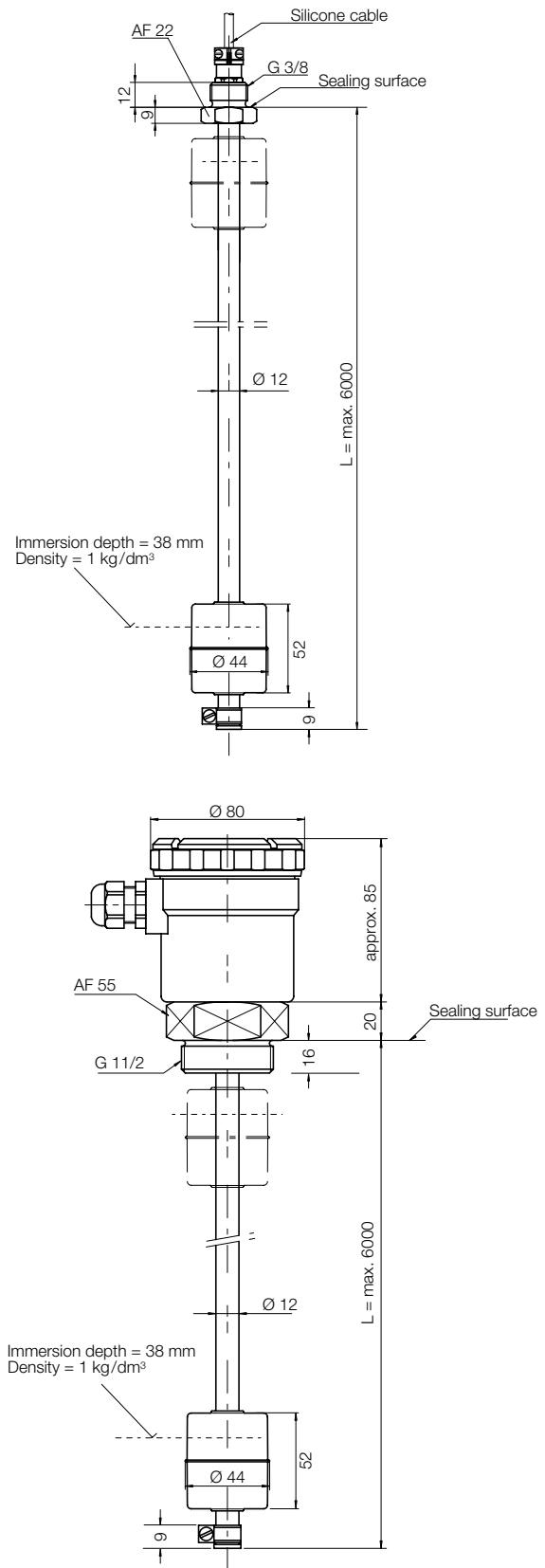

**Technical Details**

Length of measuring tube: min. 300 mm  
max. 6000 mm  
Screwed fitting: NM-299...: G 1/2  
NM-301...: G 1 1/2 or flange DN 100 PN 10

**Material**

Measuring tube and screwed fitting: stainless steel 1.4571  
Float: stainless steel 1.4571, Ø 93 mm  
Min. density: 0.72 kg/dm<sup>3</sup>  
Accuracy: 1 % of full scale value  
Nominal pressure: max. 20 bar or depending on flange design  
Medium temperature: -20 to +130 °C  
Total resistance of measuring chain: standard approx. 5000 Ω  
intrinsically safe approx. 40 000 Ω

Measuring-circuit voltage: max. 24 V<sub>DC</sub>

**Resolution**

NM-299: 15 mm  
NM-301: 10 mm (ML < 2000 mm)  
20 mm (ML ≥ 2000 mm)

Number of resistors and sealed contacts at standard matrix 15 mm: 20 pieces per 300 mm measuring chain

Electrical connection: PVC or silicone cable 3-core, length 1 m or special lengths or polyamide connecting box

ATEX approval: in preparation

**Connecting box with 2-wire transmitter type: -M**

Output: 4 - 20 mA  
Supply voltage: 16 - 32 V<sub>DC</sub>  
Load: (U<sub>B</sub> - 9 V) / 0.02 A (Ω)  
Ambient temperature: max. 70 °C

**Order Details** (Example: NM-299 R15 C)

Mechanical connection	Model	Electrical connection	Resistance
G 1/2	NM-299 R15...	...C = PVC cable ...S = silicone cable ...Y = special connection	...0 = 5 kΩ
G 1/2	NM-301 R15...	...R = connecting box ...M = with transmitter	...E = 40 kΩ
Flange DN100 PN 10	NM-301 F1H...	...Y = special connection	

Please specify measuring length "L" and cable length in writing.

**Dimensions**

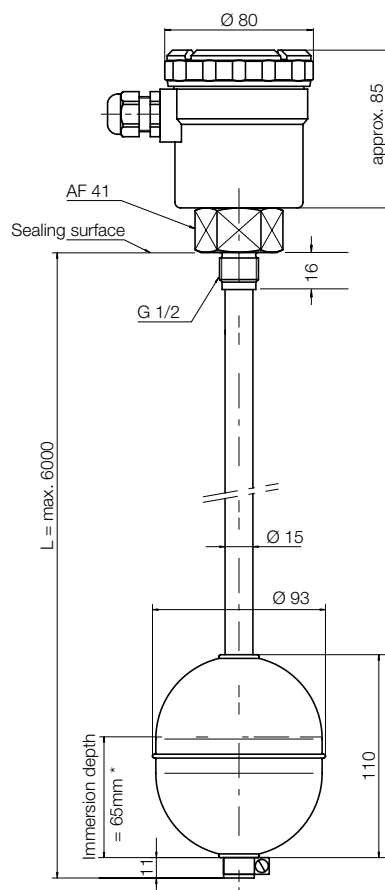
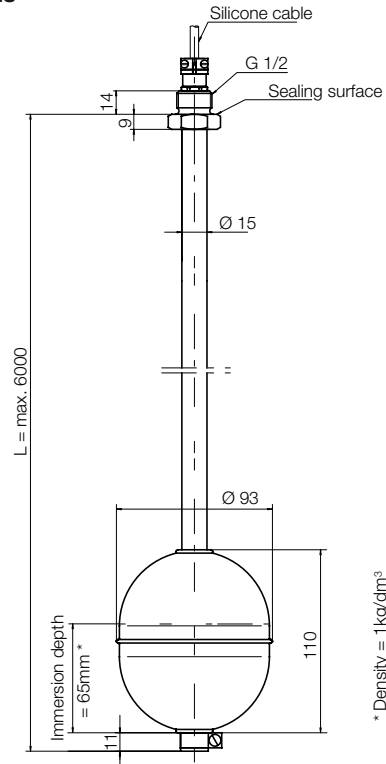

**Technical Details**

Length of measuring tube: min. 300 mm  
max. 6000 mm

Screwed fitting: G 2 or  
flange DN 65 PN 10

**Material**  
Measuring tube and  
screwed fitting: NM-310...: PVC  
NM-320...: PP-H

Float: NM-310...: PE, Ø 52 mm  
NM-320...: PP-H, Ø 52 mm

Min. density: 0.72 kg/dm<sup>3</sup>

Accuracy: 1 % of full scale value

Nominal pressure: max. 6 bar

Medium temperature: NM-310...: -20 to 60 °C  
NM-320...: -20 to 90 °C

Total resistance of  
measuring chain: standard approx. 5000 Ω  
intrinsically safe  
approx. 40 000 Ω

Measuring-circuit voltage: max. 24 V<sub>DC</sub>

Resolution: 10 mm (ML < 2000 mm)  
20 mm (ML ≥ 2000 mm)

Number of resistors and  
sealed contacts at  
standard matrix 20 mm: 20 pieces per 300 mm  
measuring chain

Electrical connection: Polyamide connecting box

**Dimensions**

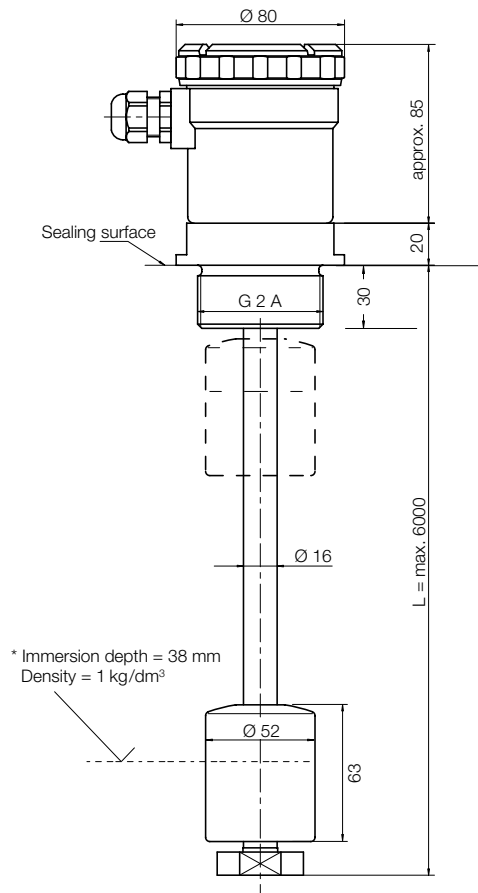

**Connecting box with 2-wire transmitter type: -M**

Output: 4 - 20 mA

Supply voltage: 16 - 32 V<sub>DC</sub>

Load: (U<sub>B</sub> - 9 V) / 0.02 A (Ω)

Ambient temperature: max. 70 °C

**Order Details (Example: NM-310 R50 R)**

Mechanical connection	Model	Electrical connection	Resistance
G 2 / PVC	NM-310 R50...	...R =connecting box ...M=with transmitter ...Y =special connection	...0 =5 kΩ ...E=40 kΩ
G 2 / PP-H	NM-320 R50...		
Flange DN 65 / PVC	NM-310 F65...		
Flange DN 65 / PP-H	NM-320 F65...		

Please specify measuring length "L" and cable length in writing.

### Technical Details

Length of measuring tube:	min. 300 mm max. 6000 mm
Screwed fitting:	G 1 or flange DN 80 PN 10
<b>Material</b>	
Measuring tube and screwed fitting:	NM-318...: PVC NM-328...: PP-H NM-338...: PTFE
Float:	NM-318...: PE, Ø 78 mm NM-328...: PP-H, Ø 78 mm NM-338...: PTFE, Ø 52 mm
Min. density:	PE: 0.6 kg/dm <sup>3</sup> PP: 0.59 kg/dm <sup>3</sup> PTFE: 0.79 kg/dm <sup>3</sup>
Accuracy:	1 % of full scale value
Nominal pressure:	max. 6 bar , 3 bar with PTFE float
Medium temperature:	NM-318...: -20 to +60 °C NM-328...: -20 to +90 °C NM-338...: -20 to +130 °C
Total resistance of measuring chain:	standard approx. 5000 Ω intrinsically safe approx. 40 000 Ω
Measuring-circuit voltage:	max. 24 V <sub>DC</sub>
Resolution:	10 mm (ML < 2000 mm) 20 mm (ML ≥ 2000 mm)
Number of resistors and sealed contacts at standard matrix 10 mm:	30 pieces per 300 mm measuring chain
Electrical connection:	PVC or silicone cable 3-core or Polyamide connecting box

### Dimensions

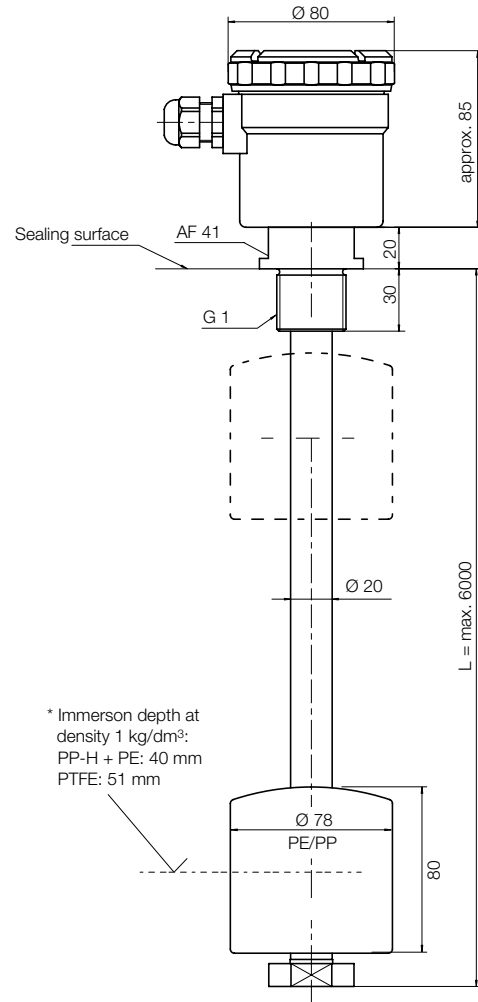

### Connecting box with 2-wire transmitter type: -M

Output:	4 - 20 mA
Supply voltage:	16 - 32 V <sub>DC</sub>
Load:	(U <sub>B</sub> -9 V) / 0.02 A (Ω)
Ambient temperature:	max. 70 °C

### Order Details (Example: NM-318 R50 R)

Mechanical connection/material	Model	Electrical connection	Resistance
G 1 / PVC	NM-318 R25...	...R = connecting box ...M = with transmitter ...Y = special connection	...0 = 5 kΩ ...E = 40 kΩ
Flange DN 80 PN 10/PVC	NM-318 F80...		
G 1 / PP-H	NM-328 R25...		
Flange DN 80 PN 10/PP-H	NM-328 F80...		
G 1 / PTFE	NM-338 R25...		
Flange DN 80 PN 10/PTFE	NM-338 F80...		

Please specify measuring length "L" in writing.