



Ultrasonic Level Meters for Liquids and Solids



measuring
•
monitoring
•
analysing



- Measuring range:
liquids: up to 8 m
solids: up to 3.5 m
- Accuracy:
0.25% max. span
- Resolution
3 mm (2-wire)
2 mm (4-wire)
- p_{max}: 3 bar abs,
t_{max}: 80 °C
- Connection:
G 1½, G 2,
1½ NPT, 2 NPT
- Case material:
Aluminium, PA66
Sensor material: PVDF
- Analogue output:
4 - 20 mA



KOBOLD companies worldwide:

ARGENTINA, AUSTRIA, BELGIUM, CANADA, CHILE, CHINA, CZECH REPUBLIK, FRANCE, GERMANY, GREAT BRITAIN, INDONESIA, ITALY, MALAYSIA, MEXICO, NETHERLANDS, PERU, POLAND, SWITZERLAND, SINGAPORE, SLOVAKIA, THAILAND, USA, VENEZUELA, VIETNAM

KOBOLD Messring GmbH
Nordring 22-24
D-65719 Hofheim/Ts.
☎ +49(0)6192 299-0
Fax +49(0)6192 23398
E-Mail: info.de@kobold.com
Internet: www.kobold.com

Model:
NUS



Description

The KOBOLD ultrasonic level meter, model NUS, is used for non-contact, continuous level measuring. The compact instrument contains an integrated temperature sensor for sound travel time compensation. The measuring range is adjustable. The instrument operates on the ultrasonic principle. The sensor transmits pulses of ultrasonic pulses to the surface of a liquid or bulk material. The reflected pulses are received by the same sensor. The electronics evaluates the echo time of the pulses and determines the level. A standard signal output for teletransmission and an LED display for local indication are available.

Applications

- Liquids
- Coarse-grained media

Dimensions

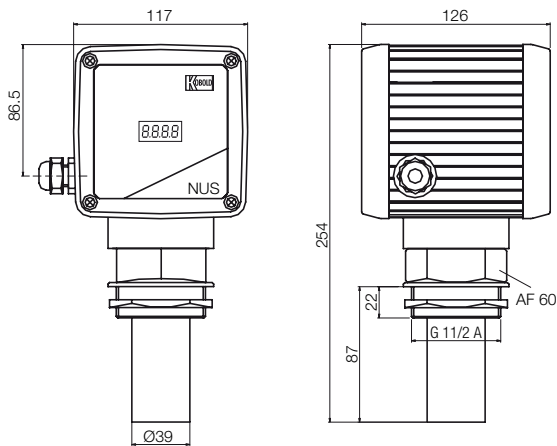

Electrical connection:
NUS-10.../NUS-20...

2-wire

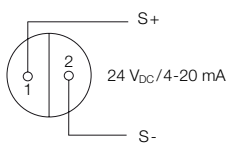

4-wire (2-pole Quickon plug)

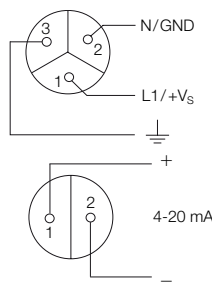

NUS-30...

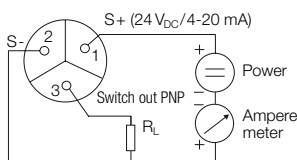

Technical Details

Measuring principle: ultrasonic principle
echo time measurement

Measuring range (liquids)
NUS-...5...: 0.25...4 m (2-wire)
0.25...5 m (4-wire)
NUS-...8...: 0.40...7 m (2-wire)
0.40...8 m (4-wire)

Measuring range (solids)
NUS-...5...: up to 2 m
NUS-...8...: up to 3.5 m

Block distance: NUS-...5...: 0.25 m
NUS-...8...: 0.40 m

Frequency: NUS-...5...: 70 kHz
NUS-...8...: 50 kHz

Pulse frequency: 0.5 to 3 Hz
(depending on electronic version)

Beam cone: 11°, conical

Min. delay time: approximately 5 s (2-wire)
approximately 1 s (4-wire)

Meas. accuracy (at 20 °C): 0.25 % of max. span

Resolution: 3 mm (2-wire)
2 mm (4-wire)

Mounting position: vertical to the surface

Process temperature: -40 to 80 °C

Ambient temperature: -20 to 60 °C

Storage temperature: -40 to 80 °C

Operating pressure: 0.7 to 3 bar abs.

Materials:
Housing: Aluminium, powder-coated
Polyamide (PA66)
PVDF / EPDM

Sensor and connection:
Connection:
NUS-...5...: G 1 1/2, 1 1/2 NPT
NUS-...8...: G 2, 2 NPT
G-thread with nut and EPDM-gasket

Design: Compact instrument

Electrical connection: 2/3-pole Quickon®

Switching output (NUS-30...): PNP, max. current load: 60 mA

Analogue output: 4 - 20 mA

Load:
NUS-10...: max. 600 Ω
NUS-20..., NUS-30...: max. 350 Ω

Supply voltage:
12 to 36 V_{DC}, 2-wire
18 to 36 V_{DC}, 4-wire
90 to 127 V_{AC}, 4-wire
180 to 250 V_{AC}, 4-wire

Display (only NUS-20/-30): 4-digit, red LED-display,
Height of digit: 7.62 mm
programmable
decimal point adjustment
Range of indication: -1999...9999

Protection: IP 65

Weight: approximately 1.6 kg (2-wire)
approximately 1.8 kg (4-wire)

Order Details (Example NUS-10 5 3 R)

Model	Version	Measuring range	Supply voltage	Connection
NUS-	10= without indication 20= with 4-digit indication 30= with indication and switching output	5=0.25...5 (4) m	3 = 12 to 36 V _{DC} , 2-wire 7 = 18 to 36 V _{DC} , 4-wire* 1 = 90 to 127 V _{AC} , 4-wire* 0 = 180 to 250 V _{AC} , 4-wire*	R=G 1 1/2 (at meas. range 5) N=1 1/2 NPT (at meas. range 5)
		8=0.40...8 (7) m		R=G 2 (at meas. range 8) N=2 NPT (at meas. range 8)

*not with NUS-30