

- Measuring length:
max. 3000 mm, one-piece
- Pressure:
max. PN 40/300 lbs
- Temperature: max. 200 °C
- Viscosity: max. 200 mm²/s
- Connection:
DIN flange DN 10 - 25
ANSI flange 1/2" - 1"
R threads and NPT threads
- Material: stainless steel 1.4571
- Rugged, reliable magnetic roller-indicator; requires no auxiliary power source
- Limit contacts
- Analogue output



KOBOLD companies worldwide:

ARGENTINA, AUSTRIA, BELGIUM, CANADA, CHILE, CHINA, CZECH REPUBLIC, FRANCE, GERMANY, GREAT BRITAIN, INDONESIA, ITALY, MALAYSIA, MEXICO, NETHERLANDS, PERU, POLAND, SWITZERLAND, SINGAPORE, SLOVAKIA, THAILAND, USA, VENEZUELA, VIETNAM

KOBOLD Messring GmbH
 Nordring 22-24
 D-65719 Hofheim/Ts.
 ☎ +49(0)6192 299-0
 Fax +49(0)6192 23398
 E-Mail: info.de@kobold.com
 Internet: www.kobold.com

Model:
NBK-M



Description

Kobold bypass level indicators are used for continuous measurement, display and monitoring of liquid levels. The bypass tube is attached onto the side wall of the vessel.

According to the law of communicating tubes the level in the bypass tube equals the level in the vessel. A float with embedded circular magnets in the bypass tube follows the liquid level and transfers it in a non-contacting manner to a display fitted outside the tube or to a monitoring device. The following indication and monitoring devices are available:

Magnetic roller indicator

As the float passes by, the red/white rollers are rotated in succession by 180° around their own axes. The rollers change from white to red as the level rises and from red to white as the level falls. The level in a tank or a mixer is continuously displayed as a red column, even when the power fails.

Transmitter

To remotely transmit the level a transmitter with a chain of resistors or a magnetostrictive transducer can be mounted outside the bypass tube. A continuous standard signal of 4 to 20 mA is generated by means of a fitted transmitter. This standard signal can then be displayed on analogue or digital indicating devices.

Universal indicating unit

A universal indicating unit of type series ADI can be mounted on the bypass to display and evaluate the standard signal (4 - 20 mA) generated by the transmitter.

Limit contacts

One or more reed contacts for limit-value acquisition or also for level control can be secured to the bypass tube.

Applications

- Storage tanks
- Mixing vessels
- Tanks on ships
- Water tanks

Technical Details

Process connection:	Flange DIN EN 1092-1 type 11, forme B ANSI flange R-thread DIN EN 10266-1 NPT thread DN 10, 15, 20, 25
Bypass tube:	Ø 40 mm
Material:	Stainless steel 1.4571
O-ring (bottom flange):	NBR 70 (-30...+100°C) (other materials as an option)
Operating pressure:	PN 6/16/40 - 150/300 lbs
Operat. temperature:	to 120°C, PP rollers to 200°C, ceramic rollers
Viscosity:	max. 200 mm ² /s
Max. meas. length:	3000 mm, one piece

Technical Details (continued)

Overall length:	see dimension drawing
Float:	Titanium, enclosed special design on request
PED 97/23/EC:	Article 3 § 3, Diagram 1, Gr. 1 no CE marking

Technical Details Additional Features

Limit contacts, models NBK-RM

Contact operation:	Bi-stable changeover contact
Switching hysteresis:	approximately 15 mm
Switching capacity:	60 W/VA; 230 V _{AC/DC} / 1 A
Resistance:	100 mΩ
Medium temperature:	max. 100°C
Ambient temperature:	max. 75°C
Connection:	3 m PVC cable
Housing:	Polycarbonate
Protection:	IP 67

Limit contact high temperature, model NBK-RT200M

Contact operation:	Bi-stable changeover contact
Switching hysteresis:	approximately 15 mm
Switching capacity:	80 VA; 250 V _{AC} , 1 A
Resistance:	< 20 mΩ
Medium temperature:	max. 200°C
Ambient temperature:	145°C
Housing:	Aluminum pressure-cast housing, terminal connection
Protection:	IP 65

Reed contact resistor chain model: ...W...

Total resistance:	approx. 5 kΩ
Meas. circuit voltage:	max. 24 V _{DC}
Measuring current:	max. 0.1 A
Medium temperature:	max. 200°C
Ambient temperature:	max. 130°C
Resolution:	10 mm (ML < 2000 mm) 20 mm (ML > 2000 mm)
Housing:	Aluminum pressure-cast
Protection:	IP 65

Reed contact resistor chain with 2-wire transmitter model: ...M...

Output:	4 - 20 mA
Auxiliary energy:	16 - 32 V _{DC}
Load:	(U _B - 9 V) / 0.02 A [Ω]
Medium temperature:	max. 120°C
Ambient temperature:	max. 80°C
Resolution:	10 mm (ML < 2000 mm) 20 mm (ML > 2000 mm)
Housing:	Aluminum pressure-cast
Protection:	IP 65



Technical Details Additional Features (continued)

Magnetostrictive sensor with 4-wire transmitter model: ...T...

Output:	4 - 20 mA
Supply voltage:	24 V _{DC} , max. 150 mA
Load:	max. 500 Ω
Max. length:	4000 mm
Medium temperature:	max. 120°C
Ambient temperature:	max. 80°C
Accuracy:	±1 mm
Housing:	Aluminum pressure-cast
Protection:	IP 65

Pressure/temperature assignment for flanges made of austenite steel; 0.2% permanent elongation limit in accordance with DIN EN 1092-1: 2001 (D).

Maximum permitted pressure:

Type	-10...+50°C	< 100°C	< 150°C	< 200°C
PN 6	5.6 bar	5.1 bar	4.7 bar	4.4 bar
PN 16	14.9 bar	13.5 bar	12.5 bar	11.7 bar
PN 40	37.3 bar	33.8 bar	31.3 bar	29.3 bar

Measuring scale, engraved, aluminium backing Option M1

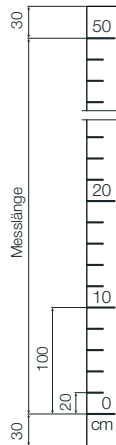

Options NBK-M

- B-* Display model ADI-B with bar graph, sturdy aluminum housing mounted on bypass tube. For description, see brochure Z2
- C- Display appliance type ADI-K with bar graph and digital display, sturdy aluminium housing, mounted on the bypass tube. For description see brochure Z2
- D- Display model ADI-D with digital display, sturdy aluminum housing mounted on bypass tube. For description, see brochure Z2
- E1- Drain flange DN 15, stainless steel 1.4571
- E2- Drain flange DN 20, stainless steel 1.4571
- E3- Drain flange, ANSI 1/2", stainless steel 1.4571
- E4- Drain flange, ANSI 3/4", stainless steel 1.4571
- L1- Drain valve G 1/4, stainless steel 1.4571
- L2- Drain valve 1/4 NPT, stainless steel 1.4571
- H1- Rinsing connection DN 15/PN 16 top and bottom
- H2- Rinsing connection ANSI 1/2", 150 lbs, top and bottom
- M1- Measuring scale to 200°C, aluminum backing, engraved scale
- M2- Measuring scale to 120°C, aluminum backing, polyester foil scale
- P- Radiographic examination DIN 54111 T1
- Q- Dye penetration test DIN EN 571-1
- X- Pressure test with water 1.5 x PN
- Z- 3.1 certificate as per EN 10204
- R1- Bottom drain screw G 1/4, PTFE seal
- R2- Bottom drain screw 1/4 NPT, no seal
- W1- O-ring (bottom flange) material: FPM (-15...+200°C)
- W2- O-ring (bottom flange) material: Silicone (-60...+200°C)
- W3- O-ring (bottom flange) material: PTFE (-20...+120°C)
- W4- O-ring (bottom flange) material: Kalrez/Chemraz (-30...+200°C)

*Use only with option T (magnetostrictive measuring sensor) or option M (resistor chain with measuring transducer)

Order Details (Example: **NBK-M1 F 10 0 0 8 0**)

Model	Nominal pressure	Connection	Nominal width	Roller display	Measuring sensor	Medium viscosity	Options
NBK-M	1 = PN 6 (not with ANSI flange) 2 = PN 16 (150 lbs) 3 = PN 40 (300 lbs)	F = DIN flange A = ANSI flange R = Tube thread N = NPT thread	10 = DN 10 (only with DIN-flange) 15 = DN 15, 1/2" 20 = DN 20, 3/4" 25 = DN 25, 1"	0 = without P = PP roller K = ceramic roller	0 = without T = magnetostrictive W = resistor chain M = resistor chain with meas. transducer	8 = from 0.8 kg/dm ³ 1 = from 1.0 kg/dm ³	0 = without ... = according to list
NBK-RM	Standard Limit Contact						
NBK-RT200M	High temperature limit contact max. 200°C						

Please show the measuring length and medium viscosity in clear text (if they deviate from 0.8 kg/dm³ or 1.0 kg/dm³).

Dimensions

NBK-M... with roller-type display

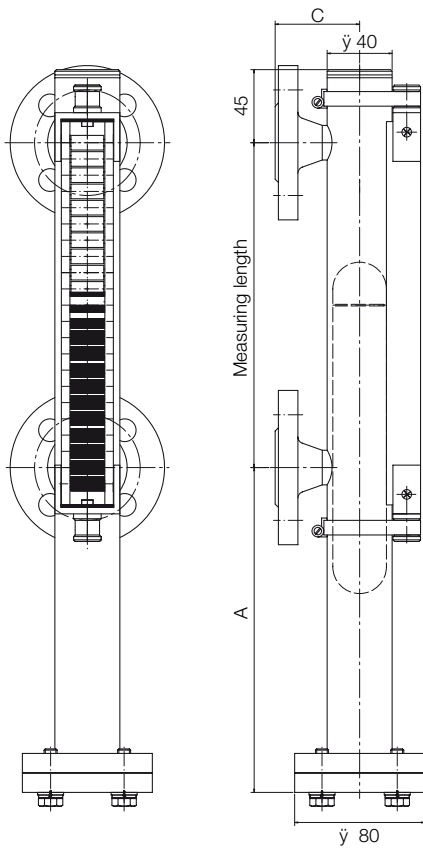

NBK-M... with roller-type display and magnetostrictive transmitter

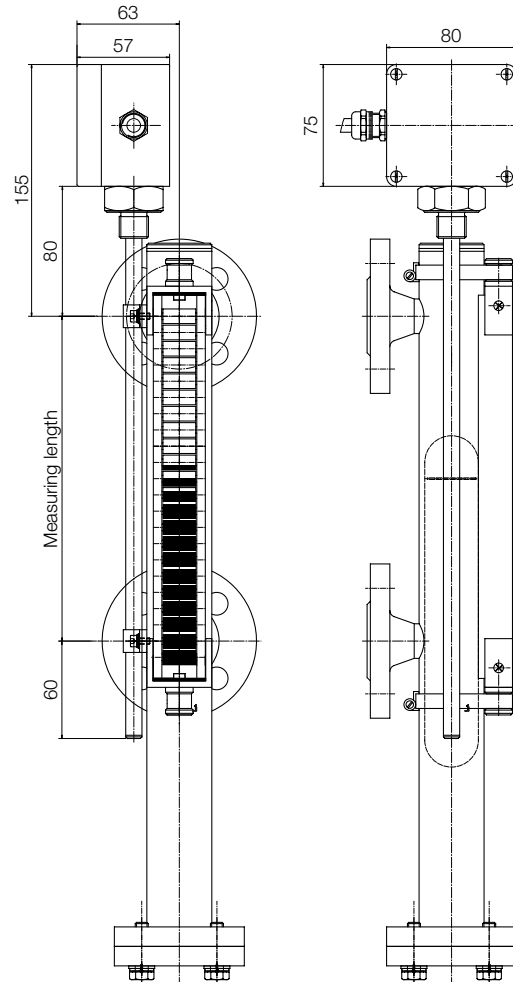

Clearance dimensions C [mm] with DIN V flange

Type	DN 10	DN 15	DN 20	DN 25
PN 6	46	47	47	72
PN 16	53	52	53	77
PN 40	53	55	55	77

Clearance

dimension A: medium density 0.8 kg/dm³: 285 mm
 Medium density 1.0 kg/dm³: 180 mm
 (with special float design dimension A may change)

Clearance dimensions C [mm] with ANSI V flange

Type	1/2"	3/4"	1"
150 lbs	64	67	66
300 lbs	69	72	73

Clearance dimension C with R or NPT thread: 60 mm