



## All-Metal Flow Meters and Switches for Liquids



measuring  
•  
monitoring  
•  
analysing



- Measuring Range:  
10-180 / 10-250 L/min  
water
- Accuracy:  
 $\pm 5\%$  f. s.
- $p_{\max}$  350 bar,  
 $t_{\max}$  100 °C
- Connection:  
G 1 ¼ female / 1 ¼ NPT
- Material:  
Brass or stainless steel



KOBOLD offices exist in the following countries:

ARGENTINA, AUSTRIA, BELGIUM, BRAZIL, CANADA, CHINA,  
FRANCE, GERMANY, GREAT BRITAIN, ITALY, MEXICO, NETHER-  
LANDS, PERU, POLAND, SWITZERLAND, USA, VENEZUELA

KOBOLD Messring GmbH  
Nordring 22-24  
D-65719 Hofheim/Ts.  
☎ +49(0)6192 299-0  
Fax +49(0)6192 23398  
E-Mail: info.de@kobold.com  
Internet: www.kobold.com

**Model:**  
SMV-..21H  
SMV-..22H



**Description**

KOBOLD flow meters and -switches series SMV-...21H and SMV-...22H are equipped with a spring loaded float which is guided within a cylindrical measuring pipe and in opposit to the principals known up to now it is hollow. The medium flows through a circular clearance which is built by the bore of the float and the mandrel bar (conical shaft) inside.

The float comprises permanent magnets actuating a bistable reed contact external to the flow circuit, that is, the flowing medium is hermetically separated from the electrical contact. In addition it is embedded in a height-adjustable switch housing thus ensuring that the contact cannot be damaged even by an aggressive atmosphere.

As the medium enters the instrument the float rises. Once its magnetic field reaches the contact tips of the reed switch the contact closes. As the flow increases the float rises further until it reaches its stop. This prevents the float from going beyond the contact range of the magnetic operating tube, that is, the contact remains closed thus ensuring bi-stable switching.

With the models SMV-2... and SMV-3... the magnetic field also activates an external, that is, hermetically separated indicator, as a result of which flows are measured accurately even at high operating pressures.

The magnetic field and the indicator are designed so as to ensure that the pointer follows even abrupt changes in flow rate.

**Applications**

- Lubrication circuits
- Paper-making machines
- Machine tools
- Glass-melting tanks
- Cooling circuits
- Welding machines
- Induction furnaces
- Pumps

**Technical Details**

Housing:	SMV-x1...: Brass, Ms 58 SMV-x2...: Stainless steel, 1.4301
Pin and o-ring:	SMV-x1...: Brass, Ms 58 SMV-x2...: Stainless steel, 1.4301
Float:	Oxide, ceramic (magnets) and SMV-x1...: Brass, Ms 58 SMV-x2...: Stainless steel, 1.4301
Spring:	Stainless steel, 1.4310
Max. temperature:	100 °C
Max. pressure:	SMV-x1...: 250 bar SMV-x2...: 350 bar
Installation position:	independent
Accuracy:	±5 % f. s.
Repeatability:	≤ 1 %

**Contacts with SMV-1..., SMV-3...**

Electrical connection:	2 m cable (SMV-...F0...) With all other types: Connector DIN 43 650
Electrical switching values:	N/O contact (CSA) max. 240 V <sub>AC</sub> / 100 VA / 1.5 A  Changeover contact (CSA) max. 240 V <sub>AC</sub> / 60 VA / 1 A  N/O contact (UL) 250 V <sub>AC</sub> - 0.4 A / 200 V <sub>DC</sub> - 0.25 A 50 V <sub>DC</sub> - 1.0 A  Changeover contact (UL) max. 250 V <sub>DC</sub> / 0.136 A - 30 V <sub>DC</sub> / 1 A
Ex-range:	ATEX-zone 1 as "simple operator"
Protection:	IP 65 (electr. contact) IP 54 (side indicator)



**Order Details**

**Flow switches with 1 contact model: SMV-1...**

(Example: SMV-1121H R0 R32)

Measuring range L/min water	Pressure loss $\Delta P$ (bar)	Float according to version		Brass	St. steel	Contact*	Connection internal thread	
		Brass	St. steel					
10...180	0.9	Brass, nickel-pl.	St. steel	SMV-1121H...	SMV-1221H...	...R0...= 1 N/O contact ...U0...= 1 changeover contact	..R32 = G 1 1/4	..N32 = 1 1/4 NPT
10...250	2.0	Brass, nickel-pl.	St. steel	SMV-1122H...	SMV-1222H...	...C0...= 1 N/O contact (UL) ...D0...= 1 changeover contact (UL)	..R32 = G 1 1/4	..N32 = 1 1/4 NPT

\*This instrument is available with two switches. Please specify in writing.

**Flow meter model: SMV-2...**

(Example: SMV-2121H 00 R32)

Measuring range L/min water	Pressure loss $\Delta P$ (bar)	Float according to version		Brass	St. steel	Contact	Connection internal thread	
		Brass	St. steel					
10...180	0.9	Brass, nickel-pl.	St. steel	SMV-2121H...	SMV-2221H...	...00...= without contact	..R32 = G 1 1/4	..N32 = 1 1/4 NPT
10...250	2.0	Brass, nickel-pl.	St. steel	SMV-2122H...	SMV-2222H...		..R32 = G 1 1/4	..N32 = 1 1/4 NPT

**Flow meter and switches with 1 contact model: SMV-3...**

(Example: SMV-3121H R0 R32)

Measuring range L/min water	Pressure loss $\Delta P$ (bar)	Float according to version		Brass	St. steel	Contact	Connection internal thread	
		Brass	St. steel					
10...180	0.9	Brass, nickel-pl.	St. steel	SMV-3121H...	SMV-3221H...	...R0...= 1 N/O contact ...U0...= 1 changeover contact	..R32 = G 1 1/4	..N32 = 1 1/4 NPT
10...250	2.0	Brass, nickel-pl.	St. steel	SMV-3122H...	SMV-3222H...	...C0...= 1 N/O contact (UL) ...D0...= 1 changeover contact (UL)	..R32 = G 1 1/4	..N32 = 1 1/4 NPT

**Order Details and Dimensions**

**1. Flow switches with 1 contact model: SMV-1...**

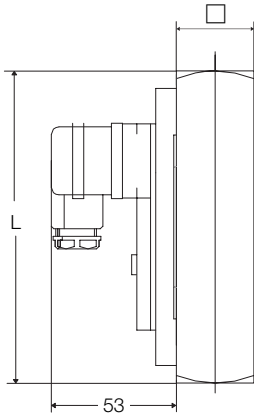

Model	Square [mm]	Thread G NPT	L [mm]	Weight [kg]
SMV-1...21H	50 x 50	1 1/4	165 (175*)	2.6
SMV-1...22H	50 x 50	1 1/4	165 (175*)	2.6

\*with NPT

**2. Flow meter model: SMV-2...**

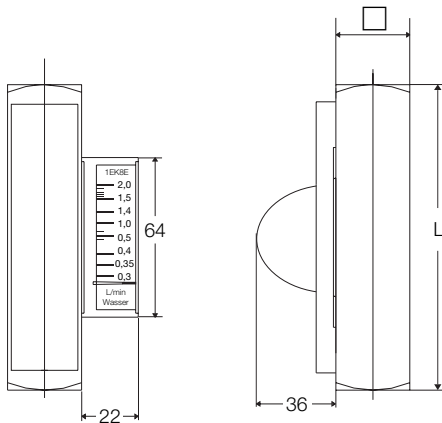

Model	Square [mm]	Thread G NPT	L [mm]	Weight [kg]
SMV-2...21H	50 x 50	1 1/4	165 (175*)	2.6
SMV-2...22H	50 x 50	1 1/4	165 (175*)	2.6

\*with NPT

**3. Flow meter and switches with 1 contact model: SMV-3...**

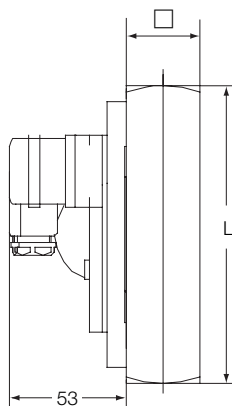

Model	Square [mm]	Thread G NPT	L [mm]	Weight [kg]
SMV-3...21H	50 x 50	1 1/4	165 (175*)	2.6
SMV-3...22H	50 x 50	1 1/4	165 (175*)	2.6

\*with NPT