



- Measuring ranges from 0.005...7500 L_N/min air
- Accuracy: ±3 % f. s.
- p_{max} 10 bar; t_{max} 70°C
- Connections: G 1/4, G 1/2, G 1
- Sensor housing: Aluminium or stainless steel
- Output: 4 - 20 mA, 0 - 5 V_{DC}
- Quick response time
- Insensitive to soiling and humidity

KOBOLD companies worldwide:

ARGENTINA, AUSTRIA, BELGIUM, CANADA, CHILE, CHINA, CZECHIA,
FRANCE, GERMANY, GREAT BRITAIN, INDIA, INDONESIA, ITALY,
MALAYSIA, MEXICO, NETHERLANDS, POLAND, SINGAPORE, SLOVAKIA,
SPAIN, SWITZERLAND, THAILAND, USA, VENEZUELA, VIETNAM

KOBOLD Messring GmbH
Nordring 22-24
D-65719 Hofheim/Ts.
☎ +49(0)6192 299-0
Fax +49(0)6192 23398
E-Mail: info.de@kobold.com
Internet: www.kobold.com

Model:
DMW



Description

The new model DMW-... direct mass flow meter has been specially designed for use in gas measuring technology. An inexpensive analogue output is fitted.

The model DMW is available in three versions: with or without integrated 3-digit LCD display or with a 8-digit counter. The direct stream procedure is ideally suited for measurements from 5 L_N/min (max.) up to 7500 L_N/min air (model: DMW-B*876). In case of small flow rates the measurements are taken with a bypass-system (DMW-A/C).

In contrast with most volumetric flow meters the mass flow meter DMW-... has no moving parts, and no temperature or pressure correction is required.

The meter may be installed in any position and the pressure loss is negligible. The simple mechanical construction ensures the highest degree of reliability when used with aggressive gases, and under tough industrial service conditions.

Application examples

- Monitoring of gases
- Counted consumption for accounting reason
- Varnishing facility
- Coating facility
- Semiconductor industry
- Laboratories and research
- Gas indication panels
- Mechanical engineering
- N₂/O₂ generators
- Burner controller

Technical Details

Measuring system:	Direct stream and Bypass
Measuring range:	3 ... 100%
Gas type:	all gases, depending on the compatibility with wetted parts
Accuracy (with calibration for air):	± 3% f. s. incl. non-linearity (other on request)
Repeatability:	± 0.5% f. s. (other on request)
Time constant (63.2%):	τ = 0.7 s (standard, other on request)
Display:	3 ½-digit LCD (flow rate); 8-digit LCD (counter)
Pressure coefficient:	0.2% / bar typically (air)
Temperature coefficient:	± 0.1% °C
Temperature range:	0 ... 70 °C
Pressure:	10 bar; higher upon request
Leakage rate:	< 2 x 10 ⁻⁹ mbar L/s He
Preheating time:	30 min for optimal accuracy; 30 s for accuracy ± 4% f. s.
Mounting position:	any, flow rate in arrow direction
Inlet section:	10 x D (DMW-A) without limitation for other types
k _{V5} -values controller:	0.066; 0.35; 1.0 (DMW-C/D)

Materials

Sensor:	Stainless steel AISI 316L
Casing:	Stainless steel AISI 316L or Aluminium (anodized)
Filter / rings:	Stainless steel/PTFE
Seal:	FPM, EPDM or Kalrez
Power supply:	24 V _{DC} ± 10%

Max. current values

DMW-A/C:	75 mA max.
DMW-B/D:	current input 250 mA max. without flow 75 mA max. 100% flow rate 175 mA max.
With valve control:	+ 250 mA max.
Signal input (with controller only):	Pot, 0 ... 5 V _{DC} or 4 ... 20 mA
Signal output:	0 ... 5 V _{DC} or 4 ... 20 mA active
Connector:	round pin plug/opposite plug, 6-pole DIN



Technical Details (cont.)

Protection: IP 40; IP 65 (option)
 Special design (upon request): » Low ΔPκ version, dry and oil-free; "fast response" version; digital design with Bus connection
 Special calibration (upon request): for example: H₂, Helium, CO₂, Methan, Propan, Butan, Argon (no oxygen)

Informations for request and order

To be able to find out the suitable instrument for your application, we ask for the following technical details:

- Gas type, measuring range
- Operating temperature and pressure (for controller, upstream and downstream pressure)
- Required output signal
- Seals

Based on this information, the following calculations or examinations are carried out:

- Converting of the desired gas-flow, based on air (the desired flow is divided by the adequate converting factor).
- *Only for controller:* Examination, whether the pressure difference over the valve (ΔP) is an acceptable range.
- *Only for controller:* Examination, whether the calculated KV-value is inside the specification.

Order Details mass flow meter (Example: DMW-A71 12 G2 F 3 2)

Measuring system	Measuring tube	Sensor housing		Measuring range [L _N /min air]*	Connection
		Aluminium	Stainless steel		
Bypass flow meter	small	DMW-A71...	DMW-A21...	..12.. = 0.005...0.1 ..22.. = 0.010...0.2 ..52.. = 0.025...0.5 ..13.. = 0.05...1.0 ..23.. = 0.1...2.0 ..53.. = 0.25...5.0 ..14.. = 0.5...10.0	..G2.. = G ¼ fem.
Direct stream flow meter	4 mm	DMW-B70...	DMW-B20...	..53.. = 0.25...5.0 ..14.. = 0.5...10.0 ..24.. = 1.0...20.0	..G2.. = G ¼ fem.
Direct stream flow meter	8 mm	DMW-B71...	DMW-B21...	..24.. = 1.0...20.0 ..54.. = 2.5...50.0 ..15.. = 5.0...100.0	..G2.. = G ¼ fem.
Direct stream flow meter	16 mm	DMW-B72...	DMW-B22...	..15.. = 5.0...100.0 ..25.. = 10.0...200.0 ..45.. = 20.0...400.0	..G4.. = G ½ fem.
Direct stream flow meter	32 mm	DMW-B73...	DMW-B23...	..55.. = 25,0...500,0 ..16.. = 50,0...1000,0 ..26.. = 100,0...2000,0	..G4.. = G ½ fem.
Direct stream flow meter	56 mm	DMW-B75...	DMW-B25...	..36.. = 150.0...3000.0 ..46.. = 200.0...4000.0 ..56.. = 250.0...5000.0	..G6.. = G 1 fem.
Direct stream flow meter	84 mm	DMW-B78...	DMW-B28...	..66.. = 300.0...6000.0 ..76.. = 375.0...7500.0	..G6.. = G 1 fem.

*L_N = Norm Litre at 1013 mbar and 0°C

L_S = Standard Litre at 1013 mbar and 20°C (others upon request)

Measuring ranges also available in m³_N/min, m³_N/h, L_N/h or others.

Seal	Indication/protection	Output
..F.. = FPM ..E.. = EPDM ..P.. = Kalrez	..3.. = without indication, IP 40 ..6.. = without indication, IP 65 ..D.. = flow rate indication, IP 40 ..Z.. = counter, IP 40	..2 = 0 - 5 V _{DC} ..4 = 4 - 20 mA



Order Details mass flow controller (Example: DMW-C71 12 G2 F 3 2)

Measuring system	Measuring tube	Sensor housing		Measuring [L _N /min air]	Connection
		Aluminium	Stainless steel		
Bypass flow meter	small	DMW-C71...	DMW-C21...	..12.. = 0.005...0.1 ..22.. = 0.010...0.2 ..52.. = 0.025...0.5 ..13.. = 0.05...1.0 ..23.. = 0.1...2.0 ..53.. = 0.25...5.0 ..14.. = 0.5...10.0	..G2.. = G 1/4 fem.
Bypass flow meter	medium	DMW-C72...	DMW-C22...	..14.. = 0.5...10.0 ..24.. = 1.0...20.0 ..54.. = 2.5...50.0	..G4.. = G 1/2 fem.
Direct stream flow meter	4 mm	DMW-D70...	DMW-D20...	..53.. = 0.25...5.0 ..14.. = 0.5...10.0 ..24.. = 1.0...20.0	..G2.. = G 1/4 fem.
Direct stream flow meter	8 mm	DMW-D71...	DMW-D21...	..24.. = 1.0...20.0 ..54.. = 2.5...50.0 ..15.. = 5.0...100.0	..G2.. = G 1/4 fem.
Direct stream flow meter	16 mm	DMW-D72...	DMW-D22...	..15.. = 5.0...100.0 ..25.. = 10.0...200.0 ..55.. = 25.0...500.0	..G4.. = G 1/2 fem.
Direct stream flow meter	32 mm	DMW-D73...	DMW-D23...	..55.. = 25.0...500.0 ..16.. = 50.0...1000.0	..G4.. = G 1/2 fem.

Seal	Indication/Protection	Input/Output
..F.. = FPM ..E.. = EPDM ..P.. = Kalrez	..3.. = without indication, IP 40 ..6.. = without indication, IP 65 ..D.. = flow rate indication, IP 40 ..Z.. = counter, IP 40	..2 = 0 - 5 V _{DC} ..4 = 4 - 20 mA ..6 = Pot/0 - 5 V _{DC} ..8 = Pot/4 - 20 mA

Pressure loss diagram

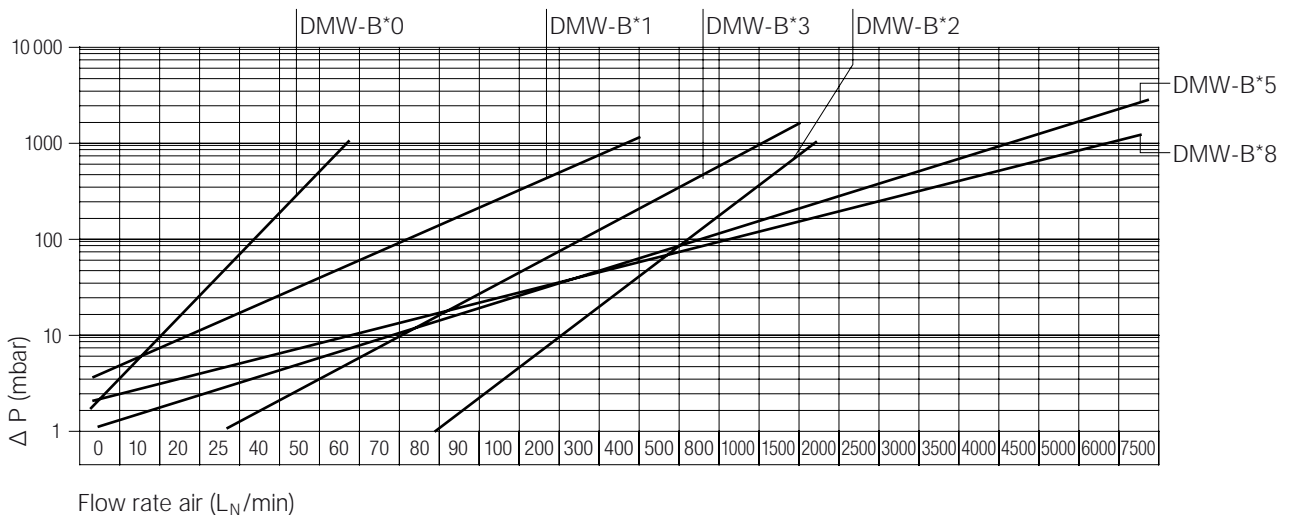

Dimensions

DMW-A..., DMW-B*0..., DMW-B*1..., DMW-B*2...

Model	B	C
DMW-A...	G 1/4	G 1/4
DMW-B*0...	G 1/4	G 1/4
DMW-B*1...	G 1/4	G 1/4
DMW-B*2...	G 1/2	G 1/2

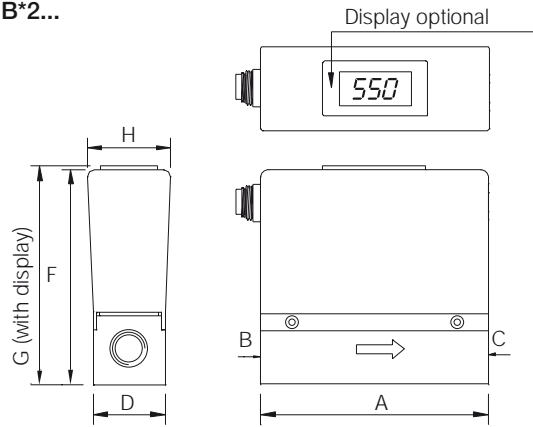

DMW-B*3..., DMW-B*5..., DMW-B*8...

Model	A	B	C	D	F	G	H
DMW-B*3...	116	G 1/2	G 1/2	50	123	125	35
DMW-B*5...	116	G 1	G 1	70	141	143	35
DMW-B*8...	143	G 1	G 1	110	171	173	35

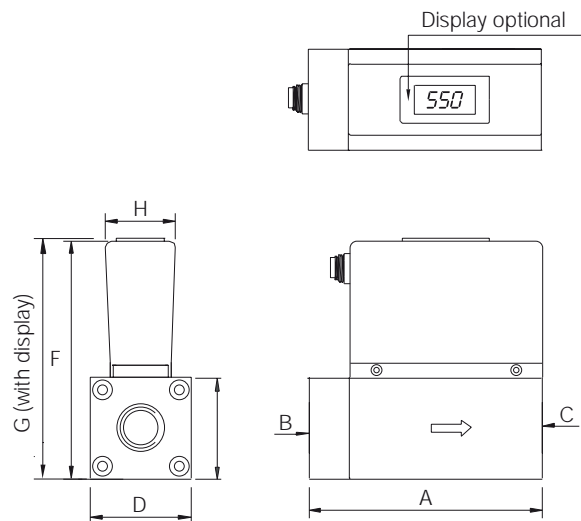



DMW-C*1..., DMW-C*2..., DMW-D*0..., DMW-D*1...

Model	A	B	C	D	F	G	H
DMW-C*1...	95	G 1/4	G 1/4	30	90	92	35
DMW-C*2...	95	G 1/2	G 1/2	30	94	96	35
DMW-D*0...	95	G 1/4	G 1/4	30	90	92	35
DMW-D*1...	95	G 1/4	G 1/4	30	90	92	35

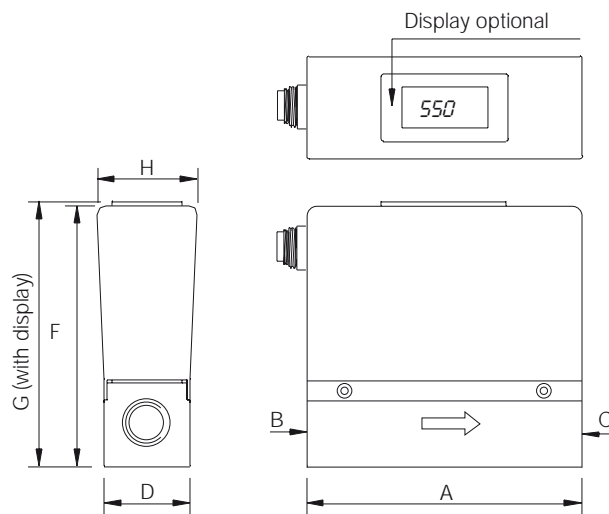

DMW-D*2..., DMW-D*3...

Model	A	B	C	D	F	G	H	I
DMW-D*2...	145	G 1/2	G 1/2	50	132	45	95	45
DMW-D*3...	-	G 1/2	G 1/2	Dimensions upon request				

