

Compact Vortex Flow Meter for Low Viscosity Liquids



- Range:
0.5-4.5 to 10-100 L/min
- Accuracy:
± 2.5 % F.S.
- p_{max} 10 bar; t_{max} 80 °C
- Connections:
G 1/4...G 1, 1/4 NPT...1 NPT
- Connection material:
Brass or stainless steel
- Switching output, frequency
output, analogue output
- Compact electronics with
digital display



KOBOLD companies worldwide:

ARGENTINA, AUSTRIA, BELGIUM, CANADA, CHILE, CHINA, CZECHIA,
 FRANCE, GERMANY, GREAT BRITAIN, INDIA, INDONESIA, ITALY,
 MALAYSIA, MEXICO, NETHERLANDS, POLAND, SINGAPORE, SLOVAKIA,
 SPAIN, SWITZERLAND, THAILAND, USA, VENEZUELA, VIETNAM

KOBOLD Messring GmbH
 Nordring 22-24
 D-65719 Hofheim/Ts.
 ☎ +49(0)6192 299-0
 Fax +49(0)6192 23398
 E-Mail: info.de@kobold.com
 Internet: www.kobold.com

Model:
 DVZ



DVZ-...S300

DVZ-...F300
DVZ-...L303
DVZ-...L343

DVZ-...L443

DVZ-...L443
(usage with AUF-3000)

DVZ-...C3...
(Compact electronics)

Description

The compact KOBOLD Vortex flow meter Type DVZ is used for measuring and monitoring smaller and medium-sized flow of low viscosity, water-like liquids in pipes. The device works using the vortex principle, making it virtually maintenance-free. This involves the installation of a sharp-edged object (the vortex generator) in the flow duct. Vortices are created behind the object whose frequency is proportional to the velocity of flow of the liquid. The flow volume can be determined with a very great degree of accuracy by measuring the vortex frequency. This achieves a very high linearity over the whole measuring range.

The device can be fitted with switching, frequency or analogue outputs. There is also an optional compact electronics package that includes a digital display, and both a switching and analogue output. Dosing and metering electronics are currently being developed.

Areas of application

- Monitoring the flow of low viscosity liquids
- Measuring of aggressive, high-purity or salty solutions
- Unsuitable for abrasive media or media containing a large proportion of fibres

Technical Data

Measurement process:	Vortex principle
Mounting position:	Any, flow in direction of arrow
Accuracy:	±2.5% of F. S.
Repeat accuracy:	±1% of F. S.
Inlet/outlet runs:	10x DN
Operating temperature:	0...80°C
Max. pressure:	10 bar
Max. pressure loss:	0.25 bar at F. S.

Wetted parts

Sensor housing:	PPS, fibreglass-reinforced
Sensor:	PVDF
Connections:	Brass, nickel plated or stainless steel 1.4404
Bluff body:	PPS, fibreglass-reinforced or oxide ceramic (non-wear version)
Seal:	NBR, EPDM or FPM
Response time:	1 s
Protection:	IP 65
Weight:	depending on version (see table)

Model	Weight fixed connections	Weight rotatable connect.
DVZ-...S300 DVZ-...F300 DVZ-...L3*3 DVZ-...L443	approx. 0.50 kg	approx. 0.90 kg
DVZ-...C3...	approx. 0.65 kg	approx. 1.10 kg

Technical Data (continued)

DVZ-...S300

Display: Duo-LED for switching condition and when range limit is exceeded

Switching output: Relay change over, max. 1 A/30 V_{DC}

Switch point: 10...100% FS in 10%-steps that can be configured by the customer using a rotary switch

Power supply: 24 V_{DC} ± 20%

Power consumption: 12 mA

Electr. connection: Plug M12x1, 5 pole

DVZ-...F300

Pulse output: PNP, Open Collector, max. 200 mA

Power supply: 24 V_{DC} ± 20%

Power consumption: 5 mA

Electr. connection: Plug M12x1

DVZ-...L303; DVZ-...L343

Output: 0(4)-20 mA, 3-wire

Max. load: 500 Ω

Power supply: 24 V_{DC} ± 20%

Electr. connection: Plug M12x1

DVZ-...L443 (usage with AUF-3000)

Output: 4-20 mA, 3-wire

Max. load: 500 Ω (250 Ω with AUF-3000)

Power supply: 24 V_{DC} ± 20%

Electr. connection: Plug DIN 43650

DVZ-...C30* (compact electronics)

Display: 3-digit LED

Type of switch. output: 2 Open Collector PNP or NPN, factory set, max. 300 mA

Contact function: N/C, N/O, frequency, programmable

Programming: with 2 keys

Power supply: 24 V_{DC} ± 20%, 3-wire techn.

Power consumption: approx. 100 mA

Electr. connection: Plug M12x1, 5-pole

DVZ-...C34* (compact electronics)

Display: 3-digit LED

Analogue output: (0)4...20 mA adjustable

Type of switch. output: 1 Open Collector PNP or NPN, factory set, max. 300 mA

Contact function: N/C, N/O, frequency, programmable

Programming: with 2 keys

Power supply: 24 V_{DC} ± 20%, 3-wire techn.

Power consumption: approx. 100 mA

Electr. connection: Plug M12x1, 5-pole

Electrical connections:

DVZ-...S300

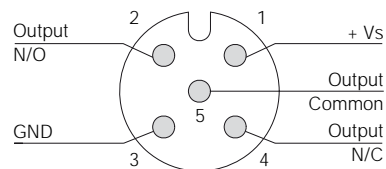

DVZ-...F300; DVZ-...L3x3

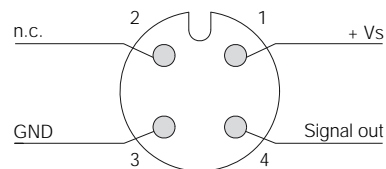

DVZ-...L443

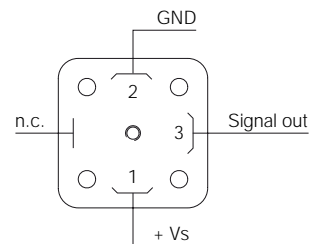

DVZ-...C30*

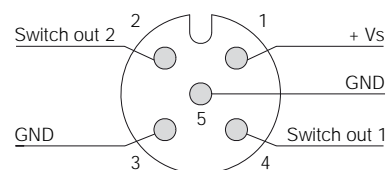

DVZ-...C34*

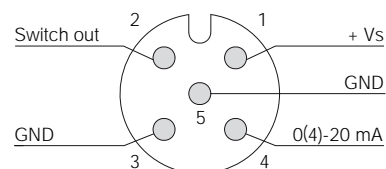



Order data (Example: DVZ-1 1 04 G2 S300)

Storage body	Connection/ Seal	Measuring range	Connections		Electronics
			fixed	rotatable	
DVZ-1.. = PPS DVZ-2.. = Ceramic	..1.. = Brass/NBR ..2.. = St. steel/NBR ..4.. = Brass/EPDM ..5.. = St. steel/EPDM ..7.. = Brass/FPM ..8.. = St. steel/FPM	..04.. = 0.5-4.5 L/min ..07.. = 0.8-7.0 L/min ..10.. = 1.0-10.0 L/min	..G2.. = G 1/4 ..G3.. = G 3/8 ..G4.. = G 1/2 ..N2.. = 1/4 NPT ..N3.. = 3/8 NPT ..N4.. = 1/2 NPT	..B2.. = G 1/4 ..B3.. = G 3/8 ..B4.. = G 1/2 ..P2.. = 1/4 NPT ..P3.. = 3/8 NPT ..P4.. = 1/2 NPT	..S300 = Switching output, M12-Plug, Relay output ..F300 = Frequency output, M12-Plug ..L303 = Analogue output, M12-Plug, 0-20 mA
		..16.. = 2.0-16.0 L/min	..G3.. = G 3/8 ..G4.. = G 1/2 ..G5.. = G 3/4 ..N3.. = 3/8 NPT ..N4.. = 1/2 NPT ..N5.. = 3/4 NPT	..B3.. = G 3/8 ..B4.. = G 1/2 ..B5.. = G 3/4 ..P3.. = 3/8 NPT ..P4.. = 1/2 NPT ..P5.. = 3/4 NPT	..L343 = Analogue output, M12-Plug, 4-20 mA ..L443 = Analogue output, DIN-Plug, 4-20 mA
		..22.. = 3.2-22.0 L/min ..32.. = 4.0-32.0 L/min	..G4.. = G 1/2 ..G5.. = G 3/4 ..G6.. = G 1 ..N4.. = 1/2 NPT ..N5.. = 3/4 NPT ..N6.. = 1 NPT	..B4.. = G 1/2 ..B5.. = G 3/4 ..B6.. = G 1 ..P4.. = 1/2 NPT ..P5.. = 3/4 NPT ..P6.. = 1 NPT	..C30R = Compact electron., 2x Open Coll., PNP ..C30M = Compact electron., 2x Open Coll., NPN ..C34P = Compact electron., 4-20 mA, 1x Open Coll., PNP
		..63*.. = 5.0-63.0 L/min ..99*.. = 10.0-100 L/min	..G5.. = G 3/4 ..G6.. = G 1 ..N5.. = 3/4 NPT ..N6.. = 1 NPT	..B5.. = G 3/4 ..B6.. = G 1 ..P5.. = 3/4 NPT ..P6.. = 1 NPT	..C34N = Compact electron., 4-20 mA, 1x Open Coll., NPN

* Measuring ranges in preparation

* Please specify flow direction in the order

Pressure loss at range end value

Model	Meas. range end value [L/min]	Pressure loss [mbar]
DVZ-__ 04	4.5	420
DVZ-__ 07	7.0	650
DVZ-__ 10	10.0	780
DVZ-__ 16	16.0	600
DVZ-__ 22	22.0	450
DVZ-__ 32	32.0	370

Dimensions

DVZ-...S300; DVZ-... F300; DVZ-...L3...
with fixed connection

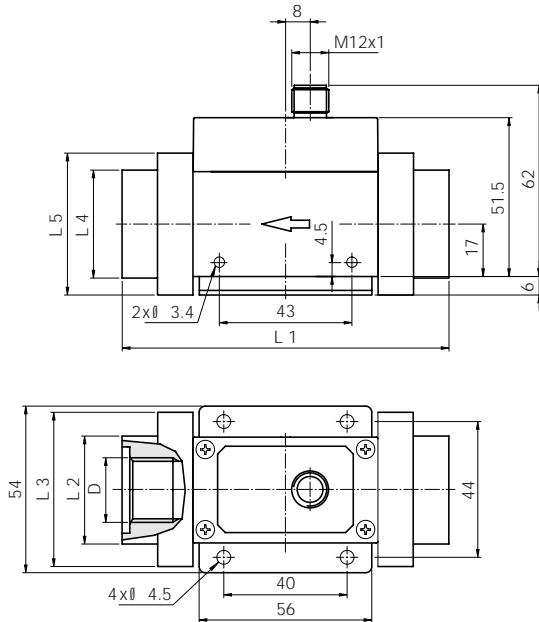

DVZ-...L443
with fixed connection

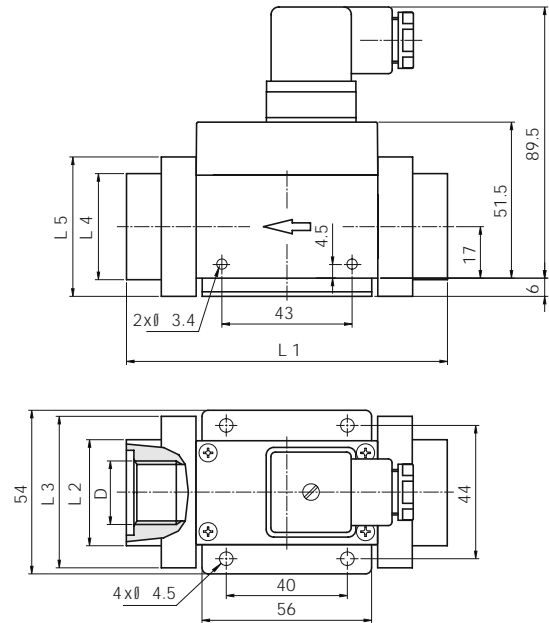

Dimensions for DVZ with fixed connection (G or NPT)

D	1/4"	3/8"	1/2"	3/4"	1"
L1	100	100	106	120	128
L2	35	35	35	34	-
L3	-	-	-	50	50
L4	35	35	35	34	-
L5	-	-	-	-	46

DVZ-...S300; DVZ-...F300; DVZ-...L3...
with rotatable connection

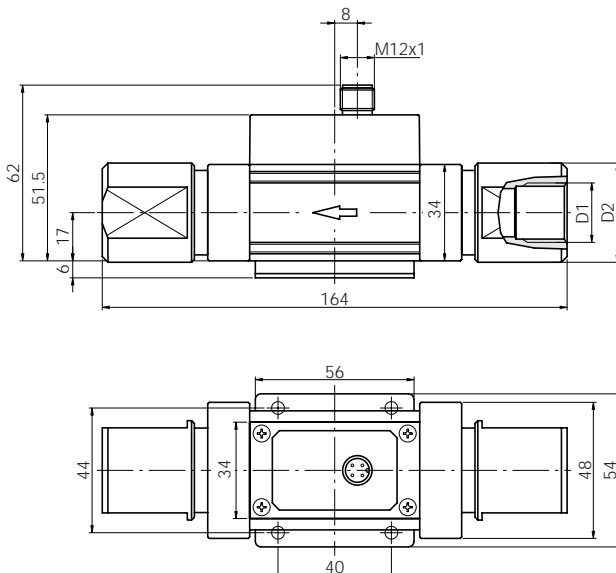

DVZ-...L443
with rotatable connection

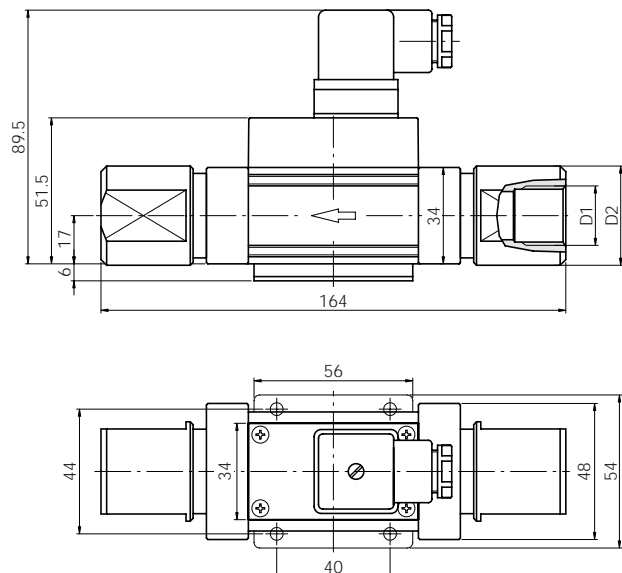

DVZ-...C3...
with fixed connection

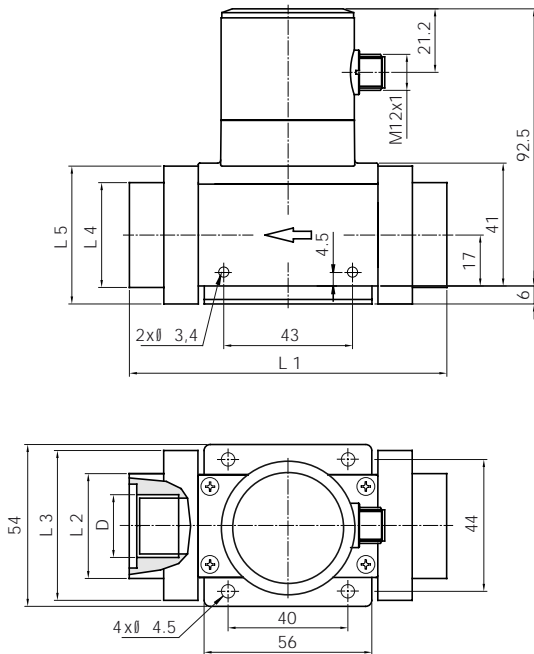

Dimensions for DVZ
with fixed connection (G or NPT)

D	1/4"	3/8"	1/2"	3/4"	1"
L1	100	100	106	120	128
L2	35	35	35	34	-
L3	-	-	-	50	50
L4	35	35	35	34	-
L5	-	-	-	-	46

DVZ-...C3...
with rotatable connection

