



- Measuring/switching range: -50 to +125°C
- Pressure: max. 80 bar
- Accuracy: ±0.5°C (for -10 to +85°C)
- Housing material: St. Steel
- Connection:  
 G 1/2, G 3/4, 1/2 NPT, 3/4 NPT or M25 x 1.5





**Description**

KOBOLD temperature switches of model TDD are used for economical measurement and monitoring of temperature. They are suited for applications where temperature must be monitored with a high degree of switching accuracy. A semiconductor, which outputs a digital signal to the evaluating electronics in 0.5 °C steps, serves as sensor element.

The current measured value is displayed on a 3-digit LED display. Two switch points, on-/off-switching delay and hysteresis are adjustable within the measuring range.

**Applications**

- Compressors
- Mechanical engineering
- Plant engineering
- Pumps

**Accessories: Electrical connection**

Description	Model
M12x1 box with terminal	ZUB-KAB-12D500
M12x1 box with 2 m cable	ZUB-KAB-12K002
M12x1 box with Quickon plug	ZUB-KAB-12Q000

**Technical Details**

Housing cover: St. steel 1.4305  
 Housing: St. steel 1.4404 (compact version)  
 St. steel 1.4305 (separate version)

**Connection compact version:**

G 1/2 or G 3/4 male thread  
 St. steel 1.4404  
 Option: 1/2 NPT or 3/4 NPT

**Connection separate version:**

Sensor: 100 mm, 6 mm, st. st. 1.4404  
 Cable: 2.5 m PTFE with M12x1 plug  
 Housing: M25x1.5 with counter nut  
 Principle of measurement: Semiconductor  
 Display: 3-digit LED, digit-height: 7 mm  
 Resolution: 0.5 °C up to 99.9 °C  
 1 °C (100 °C onwards)

Max. temperature of measured medium: -20...+120 °C (compact version)  
 -50...+125 °C (separate version)

Max. ambient temp.: -20...+50 °C

Max. pressure: 80 bar

Power supply: 24 V<sub>DC</sub> ± 20 %

Current consumption: approx 50 mA  
 (without switching output)

Electrical connection: Plug M12x1 or  
 PVC cable (cable t<sub>max</sub>: 90 °C)

Type of switching output: Semiconductor;  
 PNP or NPN (factory set),  
 max. 300 mA, short-circuit proof

Contact function: N/O / N/C, window, adjustable

Switch. point adjustment: adjustable via 2 keys

Switching display: programmable

Switching state display: 1 (2) LED

Hysteresis: adjustable via 2 keys

ON/OFF-switching delay: 0.5...99.5 (separately adjustable)  
 (only TDD-5, TDD-7)

Measuring cycle: 0.5 s

Accuracy (sensor): ± 0.5 °C (between -10...+85 °C)  
 ± 2 °C (between +85...125 °C)  
 ± 2 °C (between -50...-10 °C)

Protection cat: IP 65

**Order Codes** (Example: TDD-153 R4H2 00) Please specify cable length with order!

Electrical Connection	Model				Version	Sensor length*
	Switching output 1 x PNP	Switching output 1 x NPN	Switching output 2 x NPN	Switching output 2 x NPN		
Plug M12x1	TDD-153	TDD-353	TDD-553	TDD-753	R4H2 = G 1/2; -20...+120 °C R5H2 = G 3/4; -20...+120 °C N4H2 = 1/2 NPT; -20...+120 °C N5H2 = 3/4 NPT; -20...+120 °C D6H3 = separate version; smooth sensor; -50...+125 °C	00 = short
1 m PVC-cable	TDD-150	TDD-350	-	-		10 = 100 mm
Special cable length	TDD-159	TDD-359	-	-		20 = 200 mm

\*Separate version only with 100 mm sensor; maximum length at NPT-threads is 184 mm instead 200 mm



**Description**

KOBOLD temperature switches of model TDD are used for economical measurement and monitoring of temperature. They are suited for applications where temperature must be monitored with a high degree of switching accuracy. A semiconductor, which outputs a digital signal to the evaluating electronics in 0.5 °C steps, serves as sensor element.

The current measured value is displayed on a LED-bargraph.

**Applications**

- Compressors
- Mechanical engineering
- Plant engineering
- Pumps

**Accessories: Electrical connection**

Description	Model
M12x1 box with terminal	ZUB-KAB-12D500
M12x1 box with 2 m cable	ZUB-KAB-12K002
M12x1 box with Quickon-plug	ZUB-KAB-12Q000

**Technical Details**

Housing cover: St. steel 1.4305  
 Housing: St. steel 1.4404 (compact version)  
 St. steel 1.4305 (separate version)

**Connection compact version:**

G 1/2 or G 3/4 male thread  
 St. steel 1.4404  
 Option: 1/2 NPT or 3/4 NPT

**Connection separate version:**

Sensor: 100 mm, 6 mm, St. steel 1.4404  
 Cable: 2.5 m PTFE with M12x1 plug  
 Housing: M25x1.5 with counter nut

Principle of measurement: Semiconductor

Display: 8-digit LED-bargraph

Resolution: 5 °C

Max. temperature of measured medium: -20...+120 °C (compact version)  
 -50...+125 °C (separate version)

Max. ambient temp.: -20...+50 °C

Max. pressure: 80 bar

Power supply: 24 V<sub>DC</sub> ± 20 %

Current consumption: approx. 40 mA (without switching output)

Electrical connection: Plug M12x1 or PVC cable (cable t<sub>max</sub>: 90 °C)

Switching output: Semiconductor; PNP or NPN (factory set), max. 300 mA, short-circuit proof

Contact function: N/O / N/C, window, adjustable

Switch. point adjustment: adjustable via 2 keys

Switching display: adjustable

Switching state display: flashing LED of LED-chain

Hysteresis: adjustable via 2 keys

Measuring cycle: 0.5 s

Accuracy (sensor): ±0.5 °C (between -10...+85 °C)  
 ±2 °C (between -50...-10 °C and +85...+125 °C)

Protection cat: IP 65

**Order Codes** (Example: TDD-253 R4 00 00) Please specify cable length with order!

Electrical Connection	Model		Version Connection	Measuring range*	Sensor length**
	Switching output PNP	Switching output NPN			
M12x1 plug	TDD-253	TDD-453	R4 = G 1/2 R5 = G 3/4 N4 = 1/2 NPT N5 = 3/4 NPT D6 = separate version; smooth sensor	00 = -35...0 °C 20 = -15...+20 °C 40 = 5...40 °C 60 = 25...60 °C 80 = 45...80 °C 1H = 65...100 °C H2 = 85...120 °C	00 = short 10 = 100 mm 20 = 200 mm
1 m PVC-cable	TDD-250	TDD-450			
Special cable length	TDD-259	TDD-459			

\* Measuring range -35...0 °C only for separate version

\*\*Separate version only with 100 mm sensor; maximum length at NPT-threads is 184 mm instead 200 mm

Dimensions

Separate version short

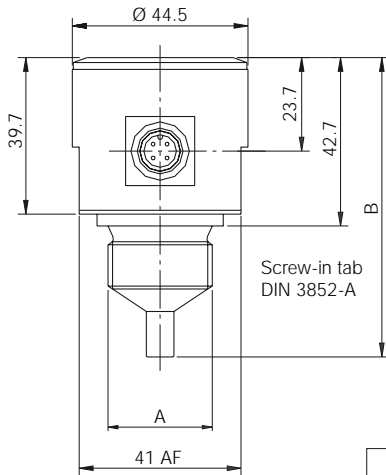

A	B
G 1/2	72,3
G 3/4	75,9
1/2-14 NPT	70,2
3/4-14 NPT	70,5

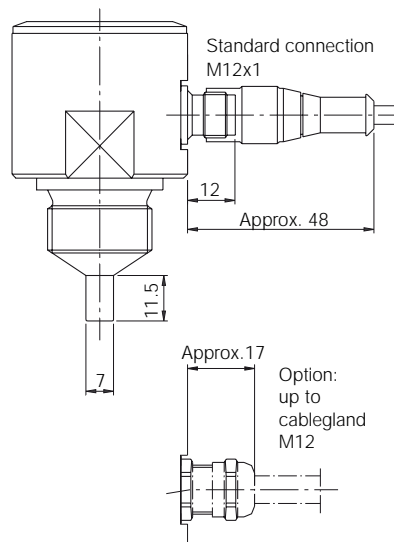

Compact version long

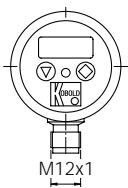
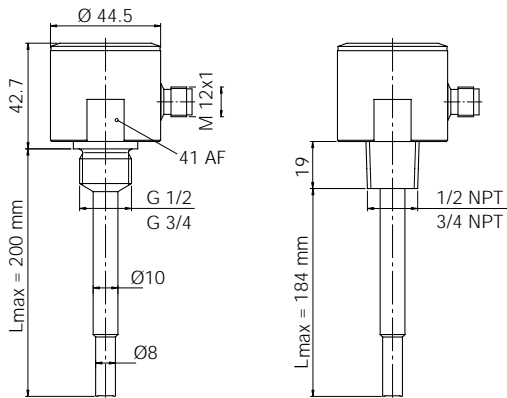

Separate version

