

Rod and Air-Duct Thermostats

for General Applications



- Switching range:
-30 to +30 to +50 to +120°C
- Material:
Housing: plastic
Probe: copper or
stainless steel
- Single contact switching



KOBOLD offices exist in the following countries:

ARGENTINA, AUSTRIA, BELGIUM, CANADA, CHINA,
COLOMBIA, FRANCE, GERMANY, GREAT BRITAIN,
NETHERLANDS, POLAND, SWITZERLAND, USA, VENEZUELA

KOBOLD Messring GmbH
Nordring 22-24
D-65719 Hofheim/Ts.
☎ (06192) 299-0
Fax (06192) 23398
E-mail: info.de@kobold.com
Internet: www.kobold.com

Model:
TEA-L
TEA-S

Description

The rod thermostats are fitted with liquid-filled probes made of copper that act as temperature-dependant pressure probes. A change in temperature causes a pressure change in the probe, which is transferred to a switch by a bellows system. A compression spring acts as a counteracting force. The switching values are set by changing the initial stress of the compression spring with a setpoint spindle. A thermowell with R 1/2 external thread made of brass or stainless steel (optional) is part of the scope of delivery.

The rod thermostats are available with adjustable switching difference or temperature switch, temperature controllers and safety temperature limiters according to DIN 3440.

Technical Details

- Material:
- Housing: impact-resistant plastic
 - Probe: copper, liquid-filled
 - Thermowell: brass, optional stainless steel 1.4301
- Connection: R 1/2 AG, depth of immersion 120 mm
- Contact operation: single-pole, floating changeover contact, dust-proof
- Switching difference: adjustable from inside.
- Switching capacity: 24 - 250 VAC, 15 A at 250 VAC, 8 A at 250 VAC inductive
- Ambient temperature: max. 55°C
- Protection: IP 65

Rod thermostats with fixed or adjustable switching difference



Dimensions

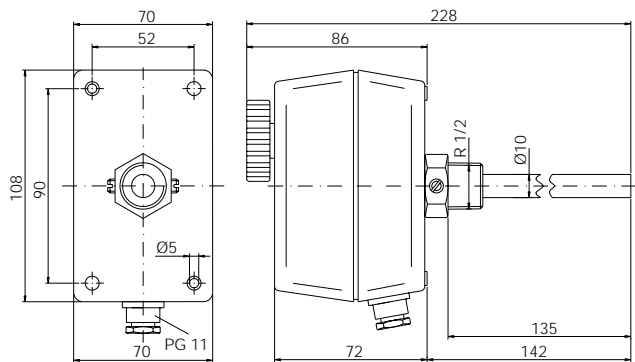

Applications

- Monitoring and control of temperatures of liquids and gases.
- Heating, ventilation, air conditioning technology
- Mechanical engineering, vessel and equipment manufacturing

Order Details (Example: TEA-S 3133 M0)

Setting range	Max. probe temperature	Hysteresis fixed 1K	Hysteresis adjustable 2-20K	Thermowell material	Option
-30 to +30°C	60°C	TEA-S 3133...	TEA-S 2133...	..M.. = brass	..0 = without
+0 to +60°C	75°C	TEA-S 3106...	TEA-S 2106...	..V.. = st. steel	..A = full internal adjustment
+20 to +90°C	100°C	TEA-S 3129...	TEA-S 2129...		
+50 to +120°C	140°C	TEA-S 3112...	TEA-S 2112...		

Rod thermostat as temperature switch, temperature controller and safety temperature limiter according to DIN 3440 and thermostats



Technical Details

Material:

- Housing: impact-resistant plastic
- Probe: copper, liquid-filled, intrinsically safe
- Thermowell: brass, optional stainless steel

Connection: R 1/2 AG, depth of immersion 120 mm,

Contact operation: single-pole, floating changeover contact, dust proof

Switching difference: fixed

Switching capacity: 24 - 250 VAC
 with rising temp.: 10 A at 250 VAC
 1.5 A inductive
 with falling temp.: 5 A at 250 VAC
 1 A inductive at 250 VAC

Switching point setting according to DIN 3440

- Temperature switch TW from inside
- Temperature controller TR from outside
- Safety temperature limiter STB from outside with reset interlock: restoration with reset button approximately 15 - 20 K below the switching temperature

The instrument switches off with low-temperature cut-off at a probe temperature < -10°C and locks

Ambient temperature: 0 - 70°C

Protection: IP 54

Dimensions

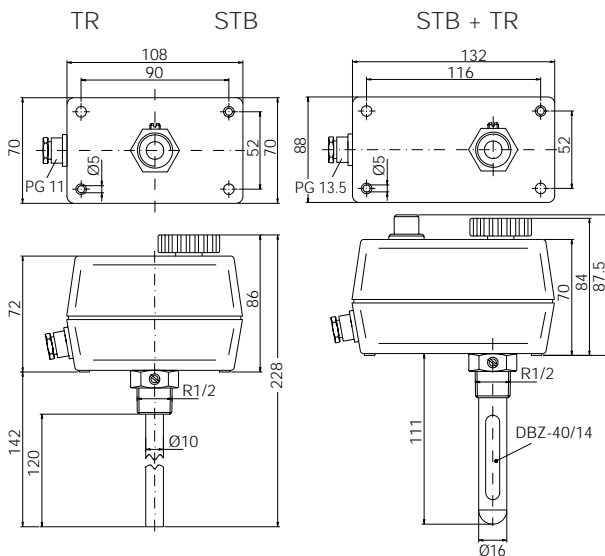

Electrical connection

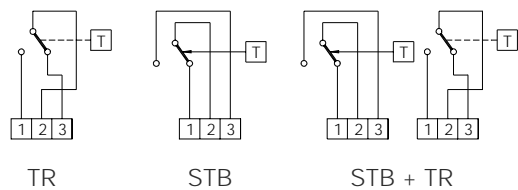

Order Details (Example: TEA-S R006 MA)

Setting range 1	Setting range 2	Function acc. to DIN 3440 F	Max. probe temperature	Switching diff. (fixed)*		Order no.	Thermowell Material
				Range 1	Range 2		
0 to +60°C	-	TR	75°C	3-5 K	-	TEA-S R006...	..MA = brass ..VA = st. steel
0 to +90°C	0 to +60°C	TR/TW	120°C	3-5 K	3-5 K	TEA-S RW09...	
0 to +60°C	+65 to +85°C	TR/STB	120°C	3-5 K	15-20 K	TEA-S RB06...	
0 to +90°C	-	TW	120°C	3-8 K	-	TEA-S W009...	
+30 to +90°C	-	TR	120°C	3-8 K	-	TEA-S R039...	
+30 to +90°C	+65 bis +85°C	TR/STB	120°C	3-8 K	15-20 K	TEA-S RB3A...	
+30 to +90°C	+90 bis +110°C	TR/STB	120°C	3-8 K	15-20 K	TEA-S RB3B...	
+50 to +140°C	-	TR	150°C	3-8 K	-	TEA-S R014...	
+65 to +85°C	-	STB	120°C	15-20 K	-	TEA-S B068...	
+90 to +110°C	-	STB	120°C	15-20 K	-	TEA-S B011...	

* Tolerance band



Description

The air thermostats are fitted with liquid-filled probes made of copper that act as temperature-dependant pressure probes. A change in temperature causes a pressure change in the probe, which is transferred to a switch by a bellows system. A compression spring acts as a counteracting force. The switching values are set by changing the initial stress of the compression spring with a setpoint spindle. The probe is protected with a coil against mechanical damage. The thermostat is secured to the duct with a clip.

The air-duct thermostats are available with adjustable switching difference or as temperature switches, temperature controllers and safety temperature limiters according to DIN 3440.

Applications

- Monitoring and control of temperatures in air channels.
- Heating, ventilation, refrigeration technology
- Vessel manufacturing and mechanical engineering

Air-duct thermostats with fixed or adjustable switching difference



Technical Details

- Material:
- Housing: impact-resistant plastic
 - Probe: copper, liquid-filled
- Depth of immersion: 190 mm
- Contact operation: single-pole, floating changeover contact, dust proof
- Switching difference: fixed or adjustable from inside
- Switching capacity: 24 - 250 VAC,
15 A at 250 VAC
8 A at 250 VAC inductive
- Ambient temperature: max. 55°C
- Protection: IP 65

Dimensions

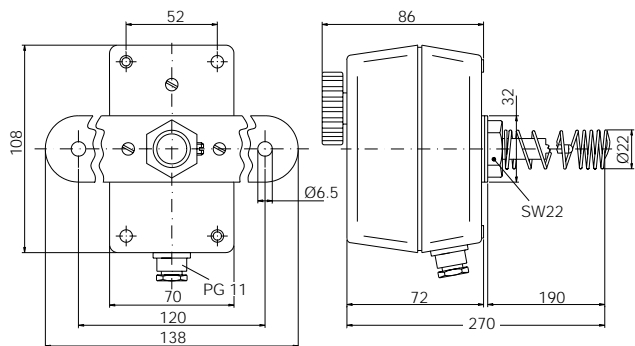

Order Details (Example: TEA-L 3113 0)

Setting range	Max. probe temperature	Hysteresis fixed 1 K	Hysteresis adjustable 2-20 K	Option
-30 to +30°C	60°C	TEA-L 3133...	TEA-L 2133...	..0 = without
0 to +60°C	75°C	TEA-L 3106...	TEA-L 2106...	..A = full internal adjustment
+20 to +90°C	100°C	TEA-L 3129...	TEA-L 2129...	
+50 to +120°C	140°C	TEA-L 3112...	TEA-L 2112...	

Air-duct thermostats as temperature switches, controllers and safety limiters according to DIN 3440 single and double contact thermostats

Dimensions

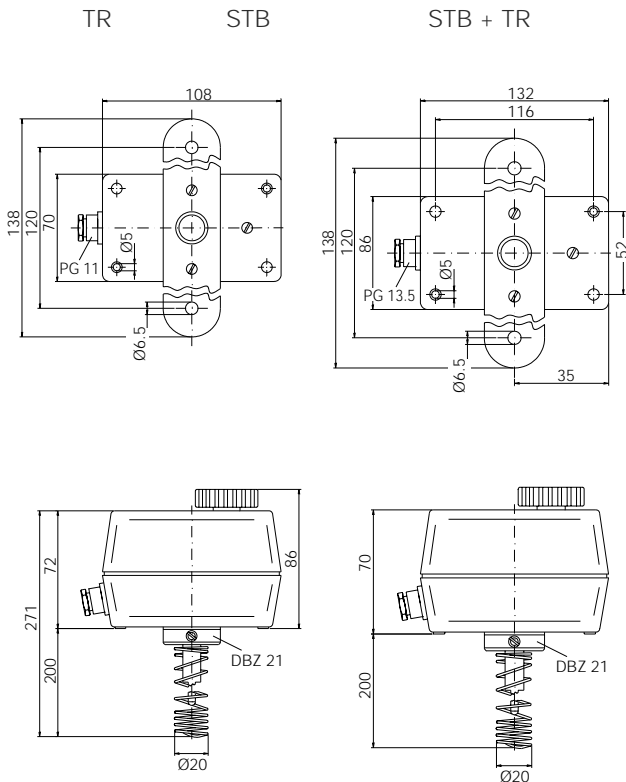

Technical Details

Material:

- Housing: impact-resistant plastic
- Probe: copper, liquid-filled, intrinsically safe

Depth of immersion: 200 mm

Contact operation: single-pole, floating changeover contact, dust proof

Switching difference: fixed

Switching capacity:
 with rising temp.: 24 - 250 VAC
 10 A at 250 VAC
 1.5 A at 250 VAC inductive
 with falling temp.: 5 A at 250 VAC
 1 A at 250 VAC inductive

Switching point setting according to DIN 3440

- Thermowell TW from inside
- Temperature controller TR from outside
- Safety temperature limiter STB from outside with reset interlock: restoration with reset button approximately 15 - 20 K below the switching temperature

The instrument switches off with low-temperature cut-off at a probe temperature < -10°C and locks

Ambient temperature: 0 - 70°C

Protection: IP 54

Electrical connection

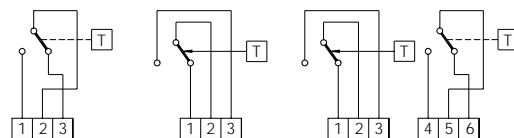

TR (TW)

STB

STB + TR

Order Details (Example: TEA-L R006)

Setting range 1	Setting range 2	Function acc. to DIN 3440 F	Max. probe temperature	Switching difference (fixed)*		Order no.
				Range 1	Range 2	
0 to +60°C	-	TR	75°C	3-5 K	-	TEA-L R006
0 to +90°C	0 to +90°C	TR/TW	120°C	3-5 K	3-5 K	TEA-L RW09
0 to +60°C	+65 to +85°C	TR/STB	120°C	3-5 K	15-20 K	TEA-L RB06
0 to +90°C	-	TW	120°C	3-5 K	-	TEA-L W009
+30 to +90°C	-	TR	120°C	3-5 K	-	TEA-L R039
+30 to +90°C	+65 bis +85°C	TR/STB	120°C	3-8 K	15-20 K	TEA-L RB3A
+30 to +90°C	+90 bis +110°C	TR/STB	120°C	3-8 K	15-20 K	TEA-L RB3B
+50 to +140°C	-	TR	150°C	3-8 K	-	TEA-L R014
+65 to +85°C	-	STB	120°C	15-20 K	-	TEA-L B068
+90 to +110°C	-	STB	120°C	15-20 K	-	TEA-L B011

* Tolerance band

Please refer to our P3 brochure...



...for pressure switches.