

## OTWK502A0091

Part Number



- Adjustable Detection Range
- Clever Inclusive Mounting Technology
- Large Detection Range
- Minimal installation space
- Simple installation

### Technical Data

<b>Optical Data</b>	
Range	500 mm
Switching Hysteresis	< 15 %
Light Source	Infrared Light
Service Life (T = +25 °C)	100000 h
max. Ambient Light	10000 Lux
Opening Angle	5 °
Light Spot Diameter	see Table 1
<b>Electrical Data</b>	
Supply Voltage	10...30 V DC
Current Consumption (U <sub>b</sub> = 24 V)	< 25 mA
Switching Frequency	500 Hz
Response Time	1 ms
Temperature Drift	< 10 %
Temperature Range	-25...60 °C
Switching Output Voltage Drop	< 2,5 V
PNP Switching Output/Switching Current	200 mA
Residual Current Switching Output	< 50 µA
Short Circuit Protection	yes
Reverse Polarity Protection	yes
Overload Protection	yes
Protection Class	III
<b>Mechanical Data</b>	
Adjustment	Potentiometer
Housing	Plastic
Degree of Protection	IP67
Connection	Prewired
Cable Length	2 m
PNP NO/NC antivalent	●
Connection Diagram No.	201
Control Panel No.	DK1
Suiting Mounting Technology No.	150 160

The transmitter and the receiver are integrated into a single housing. The sensor evaluates transmitted light reflected back from the object. The output is switched as soon as an object passes the selected range. Bright objects reflect more light than dark objects, and can thus be recognized from greater distances.

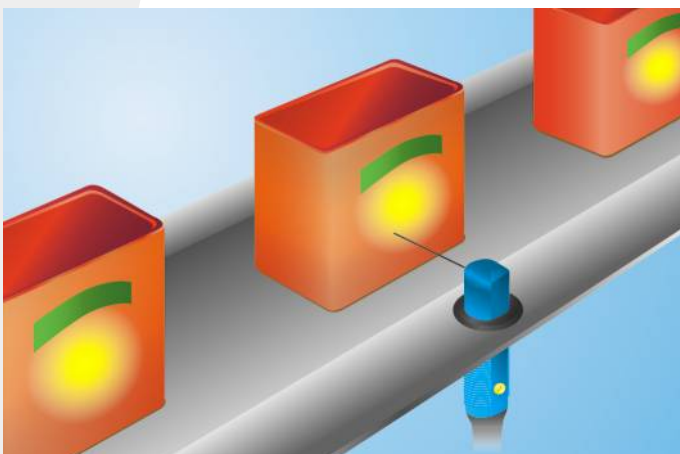

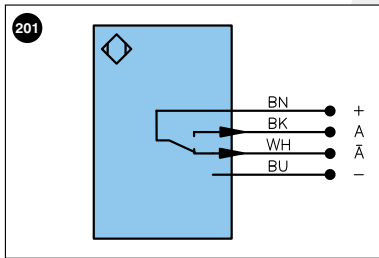
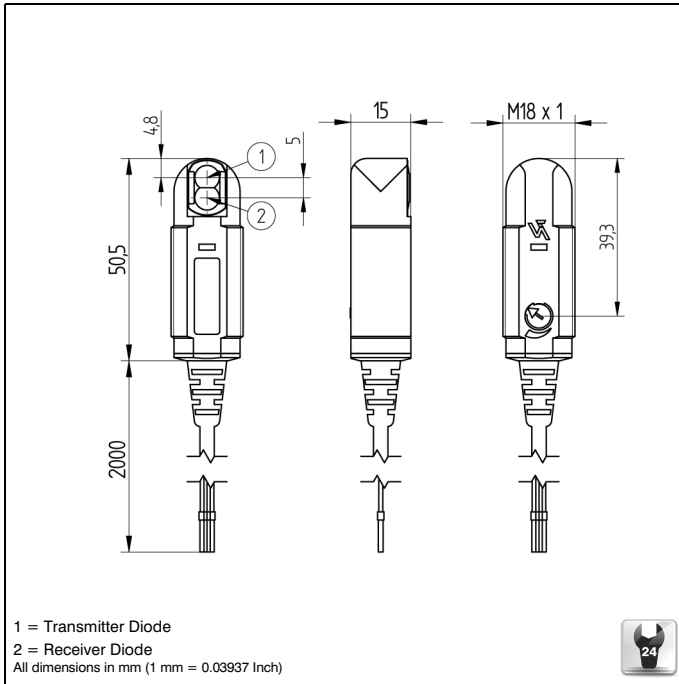

Legend			
+	Supply Voltage +	U	Test Input
-	Supply Voltage 0 V	Ū	Test Input inverted
~	Supply Voltage (AC Voltage)	W	Trigger Input
A	Switching Output (NO)	O	Analog Output
Ā	Switching Output (NC)	O-	Ground for the Analog Output
V	Contamination/Error Output (NO)	BZ	Block Discharge
V̄	Contamination/Error Output (NC)	AWV	Valve Output
E	Input (analog or digital)	a	Valve Control Output +
T	Teach Input	b	Valve Control Output 0 V
Z	Time Delay (activation)	SY	Synchronization
S	Shielding	E+	Receiver-Line
RxD	Interface Receive Path	S+	Emitter-Line
TxD	Interface Send Path	±	Grounding
RDY	Ready	SnR	Switching Distance Reduction
GND	Ground	Rx +/-	Ethernet Receive Path
CL	Clock	Tx +/-	Ethernet Send Path
E/A	Output/Input programmable	Bus	Interfaces-Bus A(+)/B(-)
	IO-Link	La	Emitted Light disengageable
		PoE	Power over Ethernet
			Wire Colors according to DIN IEC 757
		BK	Black
		BN	Brown
		RD	Red
		OG	Orange
		YE	Yellow
		GN	Green
		BU	Blue
		VT	Violet
		GY	Grey
		WH	White
		PK	Pink
		GNYE	Green Yellow

Table 1

Detection Range	100 mm	300 mm	500 mm
Light Spot Diameter	11 mm	26 mm	41 mm

Ctrl. Panel

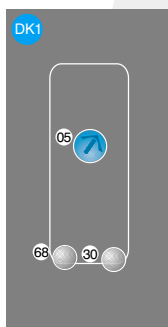

05 = Switching Distance Adjuster  
30 = Switching Status/Contamination Warning  
68 = Supply Voltage Indicator