

# WS19KK Position Sensor with Absolute Encoder

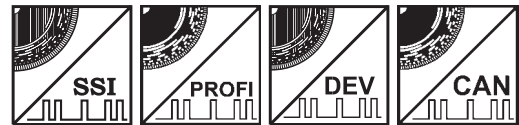

## Position Sensor with Heavy-Duty Encoder

- Protection Class IP64
- Measurement Range:  
0 ... 2000 mm up to 0 ... 15000 mm  
0 ... 78.74 in up to 0 ... 590.55 in
- With Absolute Encoder Output



Specifications	Outputs	Multiturn encoder	
	Resolution for TSSI (-P) / pulses per mm for PP24V, LD5V	WS19KK-2000: WS19KK-3000: WS19KK-5000: WS19KK-8000: WS19KK-15000 mm:	Resolution 0.04 mm 0.063 mm 0.10 mm 0.162 mm 0.146 mm
Material	Aluminium, stainless steel and plastic. Cable: Stainless Steel		
Sensing Device	Absolute Multiturn Encoder		
Connector	Depends on the encoder: 12 pin socket or bus cover		
Linearity	±0.05 % full scale, optional ±0.01 % full scale		
Protection Class (IEC 529)	IP64		
Weight	See table the page after next		
Environmental			
Immunity to Interference (EMC)	Refer to output specification		
Temperature	Refer to output specification		

## Order Code WS19KK

### Model Name

### Measurement Range (in mm)

2000 / 3000 / 5000 / 8000 / 15000

### Outputs

HSSI = Absolut encoder with SSI interface  
 HPROF = Absolut encoder with Profibus interface  
 HINT = Absolut encoder with Interbus interface  
 HDEV = Absolut encoder with DeviceNet interface  
 HCAN = Absolut encoder with CAN interface  
 HCANOP = Absolut encoder with CANopen interface

### Linearity (option)

L01 = ±0.01 % related to the specified sensitivity on the label

### Option

M4 = M4 cable fixing



## Order Code Mating Connector

SSI: **CONN-CONIN-12F-G**

**Order Example: WS19KK - 5000 - HSSI - M4**

# WS19KK Position Sensor with Incremental Encoder



## Position Sensor with Heavy-Duty Encoder

- Protection Class IP64
- Measurement Range:  
0 ... 2000 mm up to 0 ... 15000 mm  
0 ... 78.74 in up to 0 ... 590.55 in
- With Incremental Encoder Output

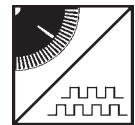

Specifications	Outputs	Incremental encoder with TTL or HTL output
	Resolution for TSSI (-P) / pulses per mm for PP24V, LD5V	WS19KK-2000: 25 pulses WS19KK-3000: 15.75 pulses WS19KK-5000: 10 pulses WS19KK-8000: 6.13 pulses WS19KK-15000 mm: 6.83 pulses
Material	Aluminium, stainless steel and plastic. Cable: Stainless Steel	
Sensing Device	Incremental Encoder	
Connector	12 pin socket	
Linearity	±0.05 % full scale, optional ±0.01 % full scale	
Protection Class (IEC 529)	IP64	
Weight	See table next page	
Environmental		
Immunity to Interference (EMC)	Refer to output specification	
Temperature	Refer to output specification	

## Order Code WS19KK

### Model Name

### Measurement Range (in mm)

2000 / 3000 / 5000 / 8000 / 15000

### Outputs

LD5VC = Incremental encoder TTL compatible

PP24VC = Incremental encoder HTL compatible

### Linearity (option)

L01 = ±0.01 % related to the specified sensitivity on the label

### Option

M4 = M4 cable fixing

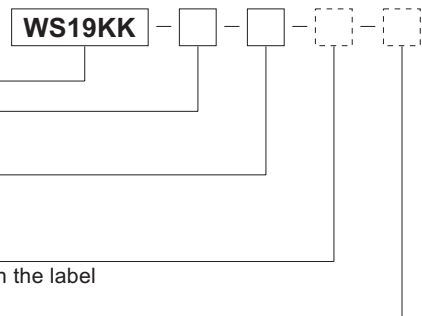

## Order Code Mating Connector

CONN-CONIN-12F-G

Order Example: WS19KK - 5000 - LD5VC - M4

# WS19KK Position Sensor with Absolute or Incremental Encoder



Cable Forces and Weights typical at 20 °C	Range		Weight [kg]	Maximum Pull-out Force [N]	Minimum Pull-in Force [N]
	[mm]	[in]			
	2000	78.74	1.5	11.0	6.2
	3000	118.11	1.7	8.0	4.1
	5000	196.85	3.2	13.1	8.6
8000	314.96	6.8	10.0	7.0	
15000	590.55	7.3	17.5	7.5	

**Outline drawing**  
WS19KK-2000 / 3000

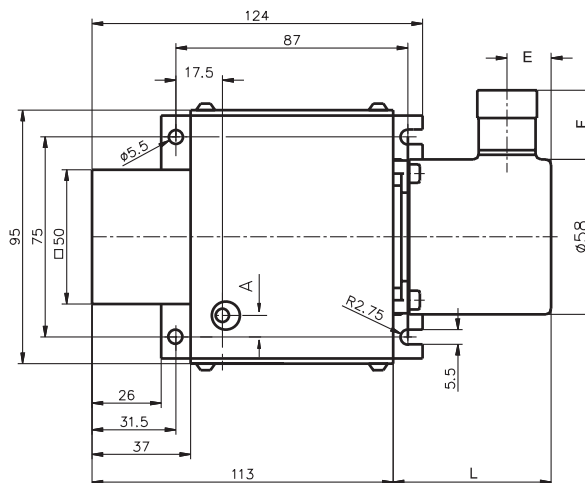
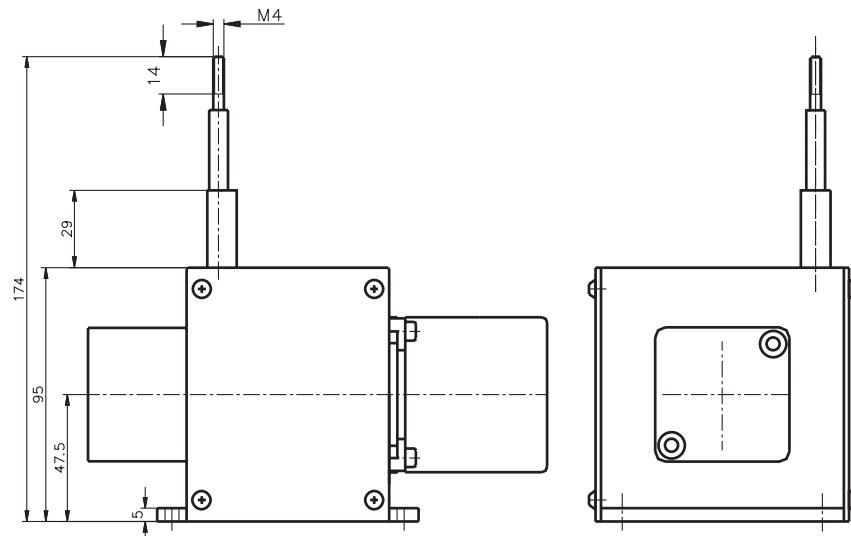

Range [mm]	Dim. A [mm]
2000	11,5
3000	0

Dimensions E, F and L depend on the encoder type

For guaranteed dimensions consult factory

# WS19KK Position Sensor with Absolute or Incremental Encoder



Outline drawing  
WS19KK-5000

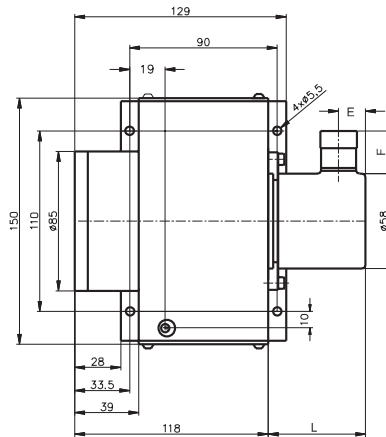
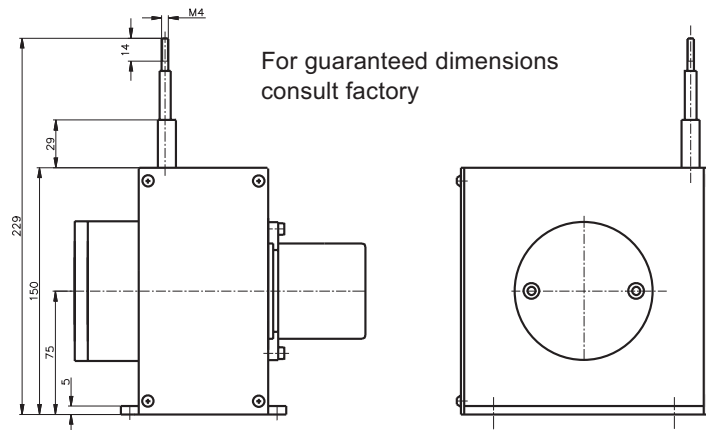

Dimensions E, F and L  
depend on the encoder  
type

Outline drawing  
WS19KK-8000

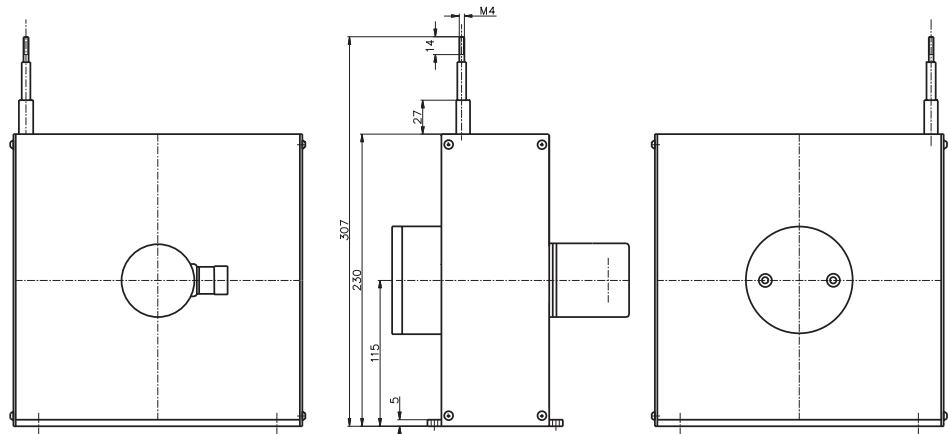

For guaranteed dimensions  
consult factory

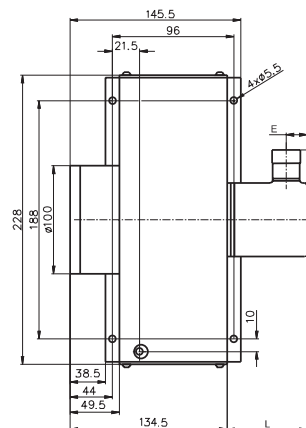

Dimensions E, F and L  
depend on the encoder  
type

# WS19KK Position Sensor with Absolute or Incremental Encoder



Outline drawing  
WS19KK-15000

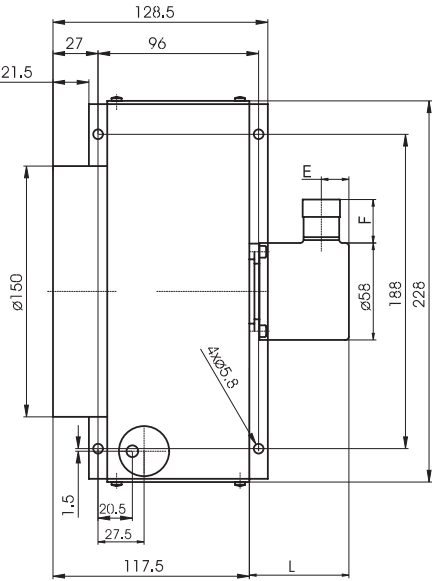
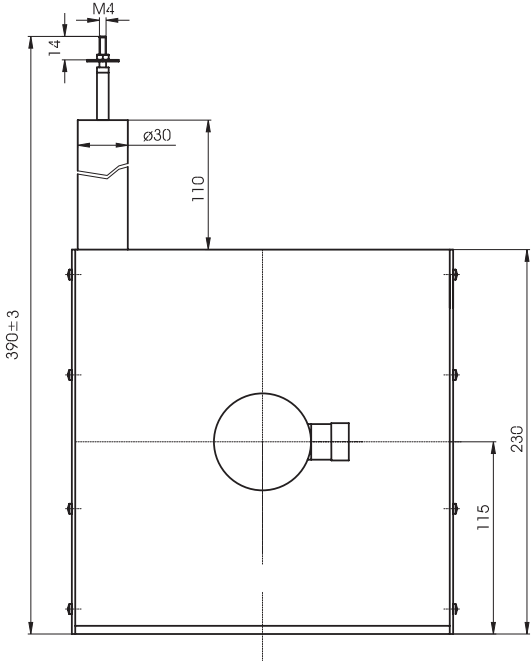

Dimensions E, F and L depend on the encoder type

Verbindliche Zeichnungen bitte vom Werk anfordern

# POSIWIRE®

## LD5VC and PP24VC

### Incremental Output



<b>Signal conditioner LD5VC</b> Incremental 	Interface	Line driver RS422
	Excitation voltage	5 V DC $\pm 10\%$
	Excitation current	150 mA max. w/o load
	Output frequency	300 kHz max.
	Output current	20 mA per channel
	Signal level	
	Ud High at Id=20 mA	$\geq 2.5$ V
	Ud Low at Id=20 mA	$\leq 0.5$ V
	Transition time positive edge	<100 ns
	Transition time negative edge	<100 ns
	Stability (temperature)	$\pm 20 \times 10^{-6}$ / °C f.s. (sensor mechanism)
	Operation temperature	-20 ... +85 °C
	Protection	Short circuit, overvoltage
	EMC	According to EN 61326:2006

<b>Signal conditioner PP24VC</b> Incremental 	Interface	Push-pull line driver (24 V-HTL)
	Excitation voltage	10 ... 30 V DC
	Excitation current	150 mA max. w/o load
	Output frequency	300 kHz max.
	Output current	100 mA per channel
	Signal level	
	Ud High at Id=20 mA, Ub=24 V	$\geq 21$ V
	Ud Low at Id=20 mA, Ub=24 V	$\leq 2.8$ V
	Transition time positive edge	<200 ns
	Transition time negative edge	<200 ns
	Stability (temperature)	$\pm 20 \times 10^{-6}$ / °C f.s. (sensor mechanism)
	Operating temperature	-20 ... +85 °C
	Protection	Reverse polarity, short circuit, overvoltage
	EMC	According to EN 61326:2006

#### Output signals

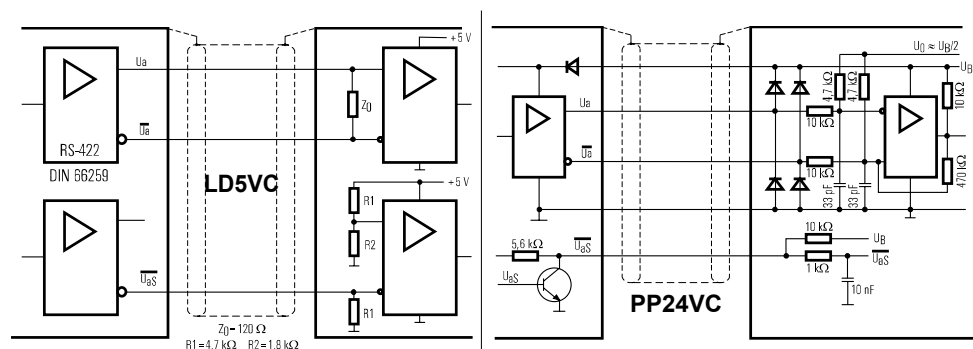
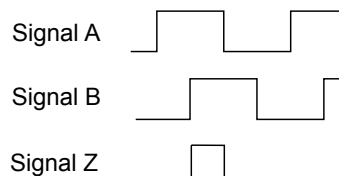

Signal name	CONN-CONIN-12F, connector pin no.
Excitation +	12
Excitation GND (0 V)	10
Signal A	5
Signal $\bar{A}$	6
Signal B (A + 90°)	8
Signal B	1
Signal Z (reference pulse)	3
Signal $\bar{Z}$	4
Fault detection signal $\bar{U}_{as}$	7
Shield	Housing

View to sensor connector

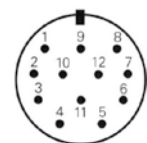

CONN-CONIN-12F

# POSIWIRE®

## HSSI

### Absolute SSI Encoder



<b>Signal conditioner</b> <b>HSSI</b> Absolute encoder synchronous serial 	Excitation voltage	10 ... 30 V DC
	Excitation current	100 mA
	Interface	Standard SSI
	Lines / drivers	Clock and data / RS422
	Code	Gray
	Resolution	12 + 12 Bit
	3 dB cutoff frequency	500 kHz
	Control input	Direction
	Alarm output	Alarm bit (SSI option), warning bit
	Status LED	Green = OK, red = alarm
	Connection	Cable or 12 pin male socket

<b>Data format</b>	<b>Resolution</b>	<b>Clock</b>												
		T1	T2	T3	...	T12	T13	...	T21	T22	T23	T24	T25	T26
		<b>Data bits</b>												
24 bit	M11	M10	M9	...	M0	S11	...	S3	S2	S1	S0	0		

Mx = multibit bits, Sx = singlet bit

<b>Transmission rate</b>	<b>Cable length</b>	<b>Baud rate</b>	<b>Note:</b> Extension of the cable length will reduce the maximum transmission rate.
	< 50 m	< 400 kHz	
	< 100 m	< 300 kHz	
	< 200 m	< 200 kHz	
	< 400 m	< 100 kHz	

<b>Signal wiring</b>	<b>Signal name</b>	<b>Color</b>	<b>Connector pin no.</b>
	Excitation +	White	8
	Excitation GND (0 V)	Brown	1
	CLOCK	Yellow	3
	CLOCK	Green	11
	DATA	Pink	2
	DATA	Grey	10
	Direction *	Blue	5
	0 V Signal output	Black	12

\* Excitation + = cw increasing code, 0 V = cw decreasing code

### Connection

View to sensor  
connector

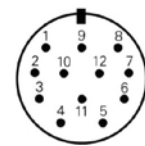

CONN-CONIN-12F

# POSIWIRE®

## HPROF

### Absolute Profibus Encoder



#### Interface HPROF

Absolute encoder  
Profibus



Excitation voltage	10 ... 30 V DC
Excitation current	250 mA
Interface	RS485
Protocol	Profibus DP with encoder profile C2
Resolution	12 (10 ... 14) + 12 bit
Output code	Binary
Baud rate	Automatically selected between 9,6 kBaud and 12 MBaud
Programmability	Resolution, preset, direction
Integrated special functions	Velocity, acceleration, operating time
Bus terminating resistor	Selectable via DIP switch
Connection	Bus cover with T manifold
EMC	EN 61326: class A

#### Signal wiring

Signal name	Cable terminal no. (bus cover)
U <sub>B</sub> in	1
0V in	2
U <sub>B</sub> out	3
0V out	4
B in	5
A in	6
B out	7
A out	8



# POSIWIRE®

## HINT

### Absolute Interbus Encoder



<b>Interface HINT</b> Absolute encoder Interbus 	Excitation voltage	10 ... 30 V DC
	Excitation current	250 mA
	Interface	Interbus, ENCOM profile K3 (configurable), K2
	Output code	32 Bit binary
	Baud rate	500 kBaud
	Data refresh	Every 600 µs
	Resolution	12 (10 ... 14) + 12 bit
	Programmability	Direction, preset, offset, resolution
	Connection	Bus cover with T manifold
	EMC	EN 50081-2, EN 50082-2

<b>Data format</b> Interbus K2/K3		Differential signals (RS485) ENCOM profile K3, K2, 32 Bit, binary process data				
	DT-Format	Supi address	0	1	2	3
	(according to the Phoenix company)	Byte No.	3	2	1	0
	ID code K2		36 H (= 54 dec.)			
	ID code K3		37 H (= 55 dec.)			

Signal wiring	Signal name	Cable terminal no. (bus cover)
		U <sub>B</sub> +
	GND	2
	DI1	3
	$\overline{DI1}$	4
	DO1	5
	$\overline{DO1}$	6
	DO2	7
	$\overline{DO2}$	8
	DI2	9
	$\overline{DI2}$	10
	RBST	11
	GND	12

**POSIWIRE®**  
**HDEV**  
**Absolute DeviceNet Encoder**



<b>Interface HDEV</b> Absolute encoder DeviceNet 	Excitation voltage	10 ... 30 V DC
	Excitation current	250 mA
	Interface	CAN highspeed according to ISO/DIS 11898 CAN specification 2.0 A (11 bit identifier)
	Protocol	DeviceNet according rev. 2.0, programmable encoder
	Resolution	12 (10 ... 14) + 12 bit
	Output code	Binary
	MAC-ID	Selectable via DIP switch
	Date refresh	Every 5 ms
	Baud rate	Selectable via DIP switch: 125 kBaud, 250 kBaud, 500 kBaud
	Programmability	Resolution, preset, direction
	Bus terminating resistor	Selectable via DIP switch
	Connection	Bus cover with T manifold
	EMC	EN 50081-2, EN 50082-2
<b>Recommended transmission</b>	Characteristic impedance	135 ... 165 Ω (3 ... 20 MHz)
	Operating capacity	< 30 pF
	Loop resistance	< 110 Ω/km
	Wire diameter	> 0.63 mm
	Wire width	> 0.34 mm <sup>2</sup>
<b>Transmission rate</b>	<b>Segment length</b>	<b>Kbit/s</b>
	500 m	125
	250 m	250
	100 m	500
<b>Signal wiring</b>	<b>Signal name</b>	<b>Cable terminal no. (bus cover)</b>
	U <sub>b</sub> in	1
	0V in	2
	CAN-L	3
	CAN-H	4
	Drain	5
	Drain	6
	CAN-H	7
CAN-L	8	

**POSIWIRE®**  
**HCAN/HCANOP**  
**Absolute CAN / CANopen Encoder**



**Interface**  
**HCAN/HCANOP**  
 Absolute encoder  
 CANopen/CAN Layer 2



Excitation voltage	10 ... 30 V DC
Excitation current	250 mA
Interface	CAN highspeed according to ISO/DIS 11898
Protocol	CANopen according DS301 with encoder profile DSP406, programmable encoder according class C2
Resolution	12 (10 ... 14) + 12 bit
Output code	Binary
Data refresh	Every millisecond (selectable), on request
Baud rate	Selectable 10 up to 1000 kbit/s
Base identifier	Selectable via DIP switch
Programmability	CANopen: direction, resolution, preset, offset CAN L2: direction, limit values
Integrated special functions	CANopen: velocity, acceleration, rotary axis, limit values CAN L2: direction, limit values
Connection	Bus cover with T manifold
EMC	EN 50081-2, EN 50082-2

**Signal wiring**

Signal name	Cable terminal no. (bus cover)
U <sub>B</sub> in	1
0V in	2
CAN in – (dominant L)	3
CAN in + (dominant H)	4
CAN GND in	5
CAN GND out	6
CAN out + (dominant H)	7
CAN out – (dominant L)	8
0V out	9
U <sub>B</sub> out	10