

COM3C

TWO-HAND CONTROL DEVICE

- Control of 2 buttons 1NO+1NC
- Desynchronism between buttons : 0,4 sec.
- 2NO + 1NC output contacts
- Test input (position switches, contactors)
- DLC short-circuit monitoring
- Plug-in terminals
- 24Vac/dc supply
- 22,5 mm housing

8A/250Vac
8A/50Vdc

POLYVALENT
POWER SUPPLY



DIGITAL
SYSTEM

SAFETY CATEGORY

COM 3C : IIC type according to EN 574

WIRING DIAGRAM

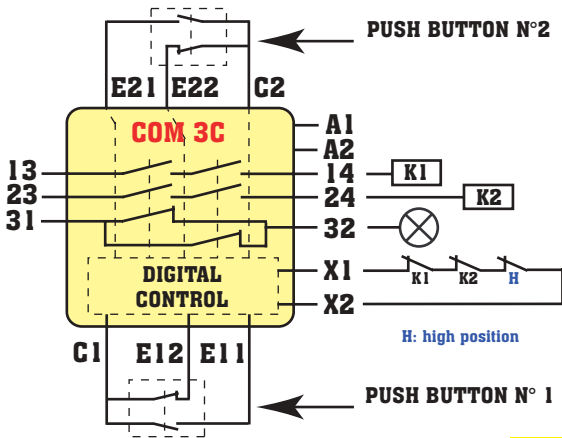

TYPE IIC

DIMENSIONS

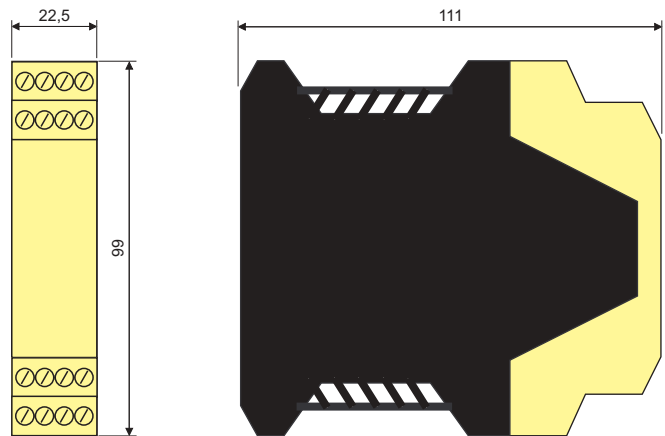

This module disposes of a new digital system allowing to keep a constant delay between the two push buttons (400 ms). It makes this module compatible even with high-speed presses and allows to improve the productivity.

ADVICE

A two hand control device type IIC designed for a high work frequency in a 22,5 mm housing.

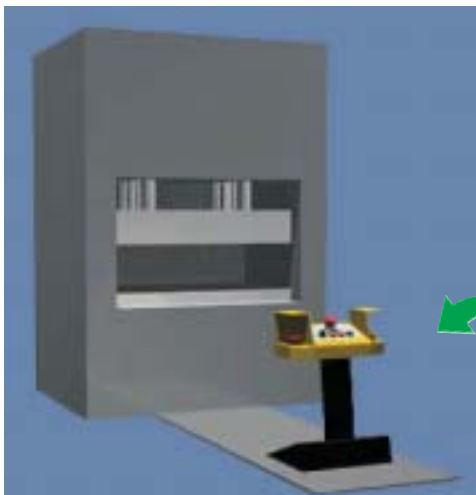

The COM3C can control a process board of a two-hand control device.