

# VALTRONIC

## PROTECTION OF OPERATORS IN DEATH ZONES

- Protection of an operator placed in a death zone
- 2 independent lines of command to activate up to 2 safety systems & 1 NC auxiliary line
- Pushing on 2 buttons of which 1 is priority
- Delaying time adjustable by incremental coders
- Delaying time: 0, 2, 4, 6, 8, 12, 16, 18, 20, 22s
- Power supply : 24V

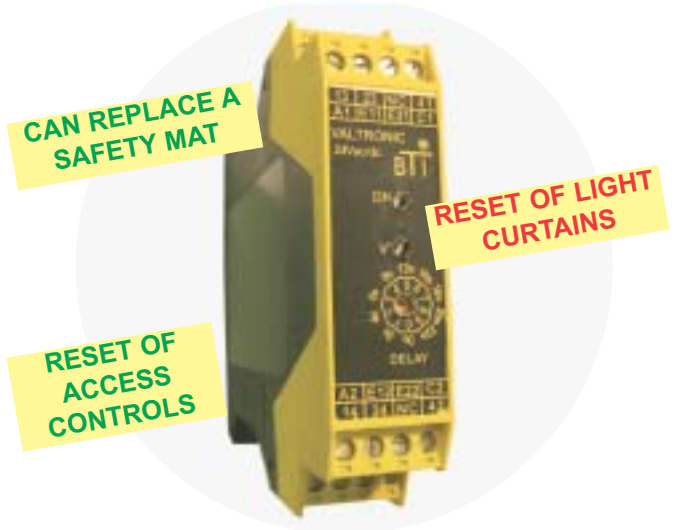

### SAFETY CATEGORY

**VALTRONIC** : Category 4 according to ISO13849-1  
The safety category depends on the system to be reset.

### WIRING EXAMPLE

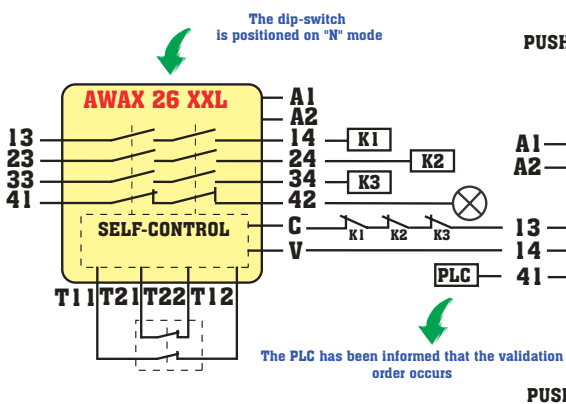

### DIMENSIONS

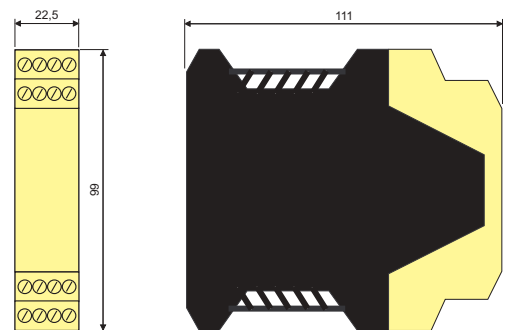

cat.4

### APPLICATION

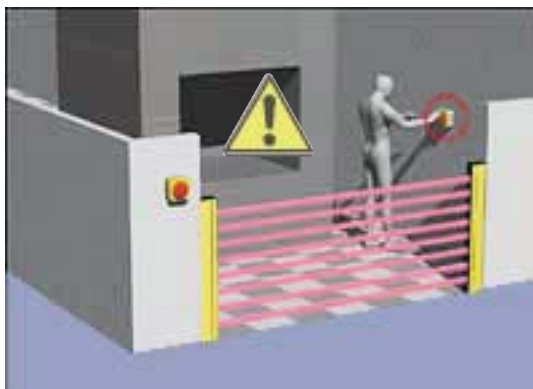

Press the A button first  
the worker is in safety

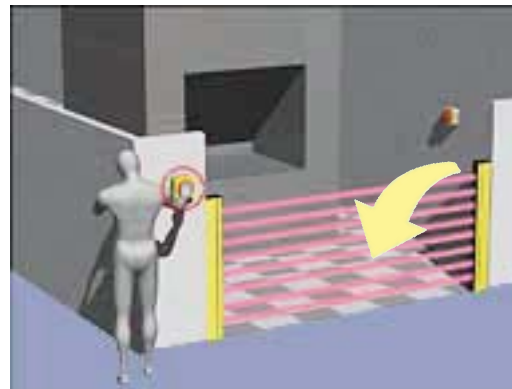

The worker gets out from the zone and presses the B button. He must do it in scheduled time to reset the machine.