

A comprehensive solution for industrial applications

# ULTRASONIC SENSORS

**microsonic-App**



Free download.

Available on the  
App Store



Extract from our online catalogue:

## Ipc ultrasonic sensors

Current to: 2015-01-12

microsonic gmbh, hauert 16, d-44227 dortmund, telephone: +49 231 975151-0, fax: +49 231 975151-51, e-mail: info@microsonic.de  
microsonic® is a registered trademark of microsonic GmbH. All rights reserved.

The lpc sensors are available as a two switched outputs, a one analogue output and a combined one analogue plus one switched output version.



## Highlights

- › **Analogue output plus 1 pnp switching output in M18 design**
- › **Automatic synchronisation** ::: for simultaneous operation of up to ten sensors in close quarters

## Basics

- › **2 switching outputs in pnp or npn variant**
- › **Analogue output 4–20 mA or 0–10 V**
- › **Analogue output plus 1 pnp switching output**
- › **microsonic Teach-in on pin 5**
- › **0.08 mm resolution**
- › **Temperature compensation**
- › **10–30 V operating voltage**
- › **LinkControl** ::: for configuration of sensors from a PC

# Description

## The sensors of the lpc sensor range

have an extremely narrow beam spread with an operating range of 250 mm and a maximum range of 350 mm. The blind zone amounts to a mere 30 mm.

### 3 output versions are available:



2 switching output, optionally in pnp oder npn circuitry



1 analogue output 4-20 mA and 0-10 V



1 analogue output with an additional pnp switching output

### Via pin 5 at the circular connector,

the lpc sensors are set (Teach-in): If pin 5 is connected to +UB, the D1 switched output is set; if pin 5 is connected to -UB, the D2 switched output is set. With the sensor version with analogue and switched output, the analogue output is set with pin 5 connected to +UB and the switched output is set with pin 5 connected to -UB.

### Two yellow LEDs,

which are laterally arranged at the M18 threaded sleeve, indicate the sensor output states and support the teach-in procedures.

### The lpc sensors with switched output

have three operating modes:

- > Single switching point
- > Two-way reflective barrier
- > Window mode

### A single switching point is set by:

- > positioning the object to be detected within the desired distance (1) to the sensor,
- > connecting pin 5 to +UB (for switched output D1) or -UB (for switched output D2) for about 3 seconds until both LEDs flash,
- > once more connecting pin 5 to +UB (for D1) or -UB (for D2) for about 1 second until the corresponding LED go out.

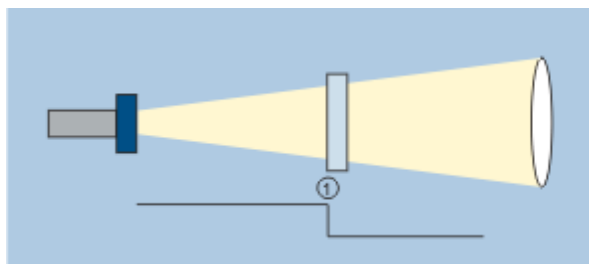

Teach-in of a switching point

### A two-way reflective barrier

can be very easily set with the help of a permanently mounted reflector. The lpcsensor is set up in window mode in such a way that the fixed reflector lies within the window.

The two-way barrier is taught to the D1 switched output by:

- > connecting pin 5 to +UB for about 3 seconds until both LEDs start to flash,
- > once more connecting pin 5 to +UB for about 10 seconds until LED 1 remain lit.

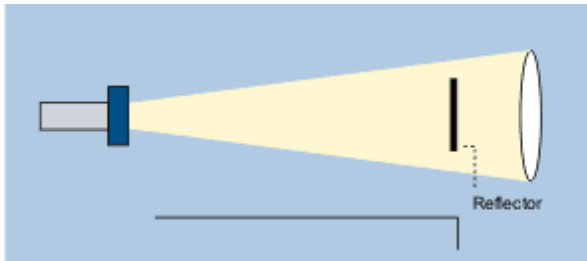

Teach-in of a two-way reflective barrier

Now, the two-way reflective barrier has been set. The D2 switched output can be set in the same way by connecting pin 5 to -UB.

### The analogue output is set by:

- > initially positioning the object to be detected on the sensor-close window limit (1),
- > connecting pin 5 to +UB for about 3 seconds until both LEDs start to flash,
- > shifting the object to the sensor-far window limit (2),
- > once more connecting pin 5 to +UB for about 1 second until LED 2 go out.

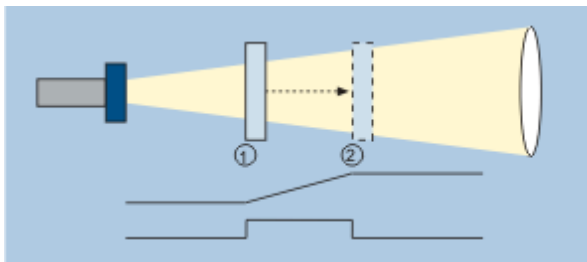

Teach-in of an analogue characteristic curve or a window with two switching points

### To set a window

with two switching points on a single switched output, the procedure is the same as setting the analogue.

### The NCC/NOC function and the rising/falling analogue characteristic

can also be set via pin 5.

### A synchronisation

of up to ten lpc sensors is possible thanks to the integrated self-synchronisation:

- > First, set the sensors in accordance with the above-described Teach-in procedures.
- > Then, switch pin 5 to the synchronisation mode by:

- disconnecting the sensors' supply voltage,
  - connecting pin 5 to -UB,
  - reconnecting the supply voltage,
  - disconnecting pin 5 from -UB as soon as LED 2 starts to flash rapidly,
  - applying pin 5 to -UB to activate the self-synchronisation and
  - waiting 10 seconds.
- Once the synchronisation mode has been activated for all sensors, the sensors must be electrically interconnected via pin 5.

All connected sensors are now automatically synchronised via pin 5. In synchronous mode, all lpc sensors implement their measurements accurately simultaneously. This prevents mutual interference. With a respectively narrow mounting distance between the sensors, a synchronised sensor can also receive echo signals from an adjacent sensor. This can, for example, be exploited to broaden the sensors' detection zone. With this, the sensors form a sensor line.

If more than ten sensors must be synchronised, this can be carried out with the SyncBox1, which is available as an accessory.

#### The default settings

of the lpc sensors can also be restored via pin 5.



#### LinkControl

consists of the LinkControl adapter and the LinkControl software and facilitates the setting of the lpc sensors with the help of a PC or notebook running any conventional Windows® operating systems. Switching points, analogue characteristic and a multitude of further settings can be read out, edited on the PC, buffered and written back to the sensor. Particularly the two measurement plotters for distance value visualisation support the development of solutions for complex automation tasks .



LinkControl adapter for lpc sensors, LinkControl adapter

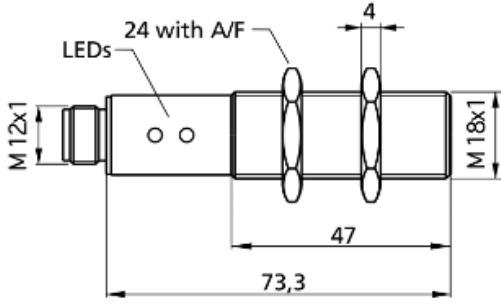
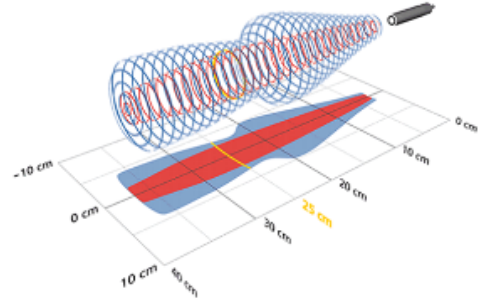

# Ipc-25/CDD/M18

| scale drawing  | detection zone  |
|--|---|
|                 |               |
|  <b>2 x pnp</b> |  <b>350 mm</b> |
| operating range  | 30 - 250 mm   |
| design   | cylindrical M18   |
| operating mode   | proximity switch/reflective mode<br>reflective barrier<br>window mode                           |
| <b>ultrasonic -specific</b>  |   |
| means of measurement   | echo propagation time measurement   |
| transducer frequency   | 320 kHz   |
| blind zone   | 30 mm   |
| operating range  | 250 mm  |
| maximum range  | 350 mm  |
| angle of beam spread   | please see graphics detection zone  |
| resolution/sampling rate   | 0.069 mm  |
| reproducibility  | ± 0.15 %  |
| accuracy   | ± 1 % (temperature drift internally compensated)  |
| <b>electrical data</b>   |   |
| operating voltage $U_B$  | 10 - 30 V d.c., reverse polarity protection   |
| voltage ripple   | ± 10 %  |
| no-load current consumption  | ≤ 40 mA   |
| type of connection   | 5-pin M12 initiator plug  |

# Ipc-25/CDD/M18

|   |   |
|---|---|
| <b>outputs</b>                            |   |
| output 1                                  | switching output<br>pnp: $I_{max} = 200 \text{ mA}$ ( $U_B - 2V$ )<br>NOC/NCC adjustable, short-circuit-proof |
| output 2                                  | switching output<br>pnp: $I_{max} = 200 \text{ mA}$ ( $U_B - 2V$ )<br>NOC/NCC adjustable, short-circuit-proof |
| switching hysteresis                      | 2.0 mm  |
| switching frequency                       | 25 Hz   |
| response time                             | 24 ms   |
| delay prior to availability               | < 300 ms  |
| <b>inputs</b>                             |   |
| input 1                                   | com input<br>teach-in input   |
| <b>housing</b>                            |   |
| material                                  | brass sleeve, nickel-plated, plastic parts, PBT   |
| ultrasonic transducer                     | polyurethane foam, epoxy resin with glass contents  |
| class of protection to EN 60529           | IP 67   |
| operating temperature                     | -25°C to +70°C  |
| storage temperature                       | -40°C to +85°C  |
| weight                                    | 43 g  |
| further versions                          | stainless steel<br>high chemical resistance   |
| <b>technical features/characteristics</b> |   |
| temperature compensation                  | yes   |
| controls                                  | com input   |
| scope for settings                        | Teach-in via com input on pin 5<br>LCA-2 with LinkControl   |
| synchronization                           | yes   |
| multiplex                                 | no  |
| indicators                                | 2 x LED yellow: switch status   |
| <b>documentation (download)</b>           |   |
| pin assignment                            |   |

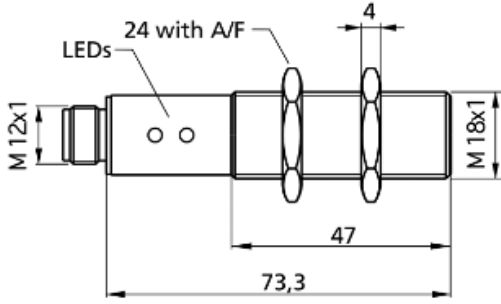
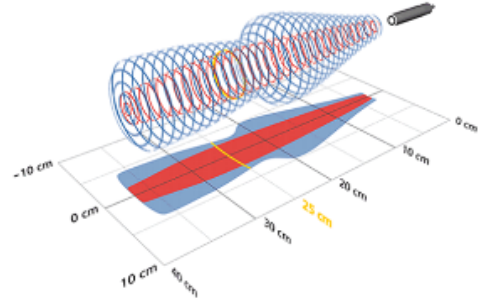
# Ipc-25/CEE/M18



| scale drawing  | detection zone  |
|--|---|
|                 |               |
|  <b>2 x npn</b> |  <b>350 mm</b> |
| operating range  | 30 - 250 mm   |
| design   | cylindrical M18   |
| operating mode   | proximity switch/reflective mode<br>reflective barrier<br>window mode                           |
| <b>ultrasonic -specific</b>  |   |
| means of measurement   | echo propagation time measurement   |
| transducer frequency   | 320 kHz   |
| blind zone   | 30 mm   |
| operating range  | 250 mm  |
| maximum range  | 350 mm  |
| angle of beam spread   | please see graphics detection zone  |
| resolution/sampling rate   | 0.069 mm  |
| reproducibility  | ± 0.15 %  |
| accuracy   | ± 1 % (temperature drift internally compensated)  |
| <b>electrical data</b>   |   |
| operating voltage $U_B$  | 10 - 30 V d.c., reverse polarity protection   |
| voltage ripple   | ± 10 %  |
| no-load current consumption  | ≤ 40 mA   |
| type of connection   | 5-pin M12 initiator plug  |



# Ipc-25/CEE/M18

|   |  |
|---|--|
| <b>outputs</b>                            |  |
| output 1                                  | switching output<br>npn: $I_{max} = 200 \text{ mA}$ ( $-U_B + 2V$ )<br>NOC/NCC adjustable, short-circuit-proof |
| output 2                                  | switching output<br>npn: $I_{max} = 200 \text{ mA}$ ( $-U_B + 2V$ )<br>NOC/NCC adjustable, short-circuit-proof |
| switching hysteresis                      | 2.0 mm   |
| switching frequency                       | 25 Hz  |
| response time                             | 24 ms  |
| delay prior to availability               | < 300 ms   |
| <b>inputs</b>                             |  |
| input 1                                   | com input<br>teach-in input  |
| <b>housing</b>                            |  |
| material                                  | brass sleeve, nickel-plated, plastic parts, PBT  |
| ultrasonic transducer                     | polyurethane foam, epoxy resin with glass contents   |
| class of protection to EN 60529           | IP 67  |
| operating temperature                     | -25°C to +70°C   |
| storage temperature                       | -40°C to +85°C   |
| weight                                    | 43 g   |
| <b>technical features/characteristics</b> |  |
| temperature compensation                  | yes  |
| controls                                  | com input  |
| scope for settings                        | Teach-in via com input on pin 5<br>LCA-2 with LinkControl  |
| synchronization                           | yes  |
| multiplex                                 | no   |
| indicators                                | 2 x LED yellow: switch status  |
| <b>documentation (download)</b>           |  |
| pin assignment                            |  |

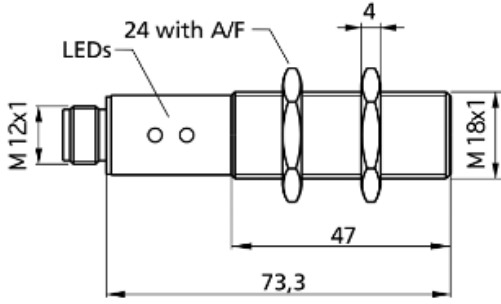
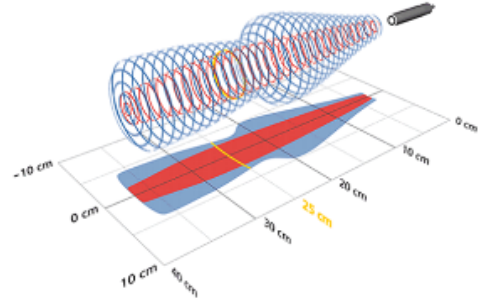

# Ipc-25/CDU/M18

| scale drawing  | detection zone  |
|--|---|
|                                       |               |
|  <b>1 x pnp + 1 x analogue 0-10 V</b> |  <b>350 mm</b> |
| operating range  | 30 - 250 mm   |
| design   | cylindrical M18   |
| operating mode   | proximity switch/reflective mode  |
|  | reflective barrier  |
|  | window mode   |
| <b>ultrasonic -specific</b>  |   |
| means of measurement   | echo propagation time measurement   |
| transducer frequency   | 320 kHz   |
| blind zone   | 30 mm   |
| operating range  | 250 mm  |
| maximum range  | 350 mm  |
| angle of beam spread   | please see graphics detection zone  |
| resolution/sampling rate   | 0,069 mm bis 0,078 mm, abhängig vom eingestellten Analogfenster                                 |
| reproducibility  | ± 0.15 %  |
| accuracy   | ± 1 % (temperature drift internally compensated)  |
| <b>electrical data</b>   |   |
| operating voltage $U_B$  | 10 - 30 V d.c., reverse polarity protection   |
| voltage ripple   | ± 10 %  |
| no-load current consumption  | ≤ 40 mA   |
| type of connection   | 5-pin M12 initiator plug  |

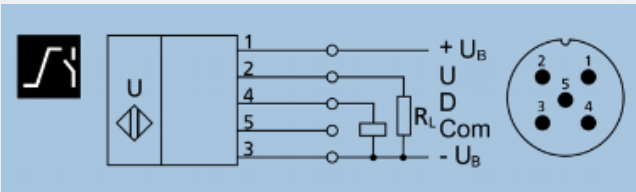
# Ipc-25/CDU/M18

|   |   |
|---|---|
| <b>outputs</b>                            |   |
| output 1                                  | analogue output<br>voltage: 0-10 V, short-circuit-proof<br>switchable rising/falling                          |
| output 2                                  | switching output<br>pnp: $I_{max} = 200 \text{ mA}$ ( $U_B - 2V$ )<br>NOC/NCC adjustable, short-circuit-proof |
| switching hysteresis                      | 2.0 mm  |
| switching frequency                       | 25 Hz   |
| response time                             | 24 ms   |
| delay prior to availability               | < 300 ms  |
| <b>inputs</b>                             |   |
| input 1                                   | com input<br>teach-in input   |
| <b>housing</b>                            |   |
| material                                  | brass sleeve, nickel-plated, plastic parts, PBT   |
| ultrasonic transducer                     | polyurethane foam, epoxy resin with glass contents  |
| class of protection to EN 60529           | IP 67   |
| operating temperature                     | -25°C to +70°C  |
| storage temperature                       | -40°C to +85°C  |
| weight                                    | 43 g  |
| <b>technical features/characteristics</b> |   |
| temperature compensation                  | yes   |
| controls                                  | com input   |
| scope for settings                        | Teach-in via com input on pin 5<br>LCA-2 with LinkControl   |
| synchronization                           | yes   |
| multiplex                                 | no  |
| indicators                                | 1 x LED yellow: switch status, 1 x LED yellow: object in the window   |
| <b>documentation (download)</b>           |   |
| pin assignment                            |                           |

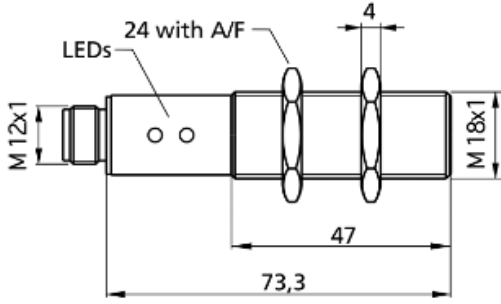
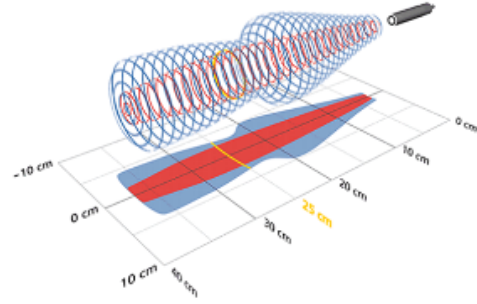

# Ipc-25/CDI/M18

| scale drawing   | detection zone   |
|---|--|
|                                        |                      |
|  <b>1 x pnp + 1 x analogue 4-20 mA</b> |  <b>350 mm</b>        |
| operating range   | 30 - 250 mm  |
| design  | cylindrical M18  |
| operating mode  | proximity switch/reflective mode<br>reflective barrier<br>window mode<br>analogue distance measurement |
| <b>ultrasonic -specific</b>   |  |
| means of measurement  | echo propagation time measurement  |
| transducer frequency  | 320 kHz  |
| blind zone  | 30 mm  |
| operating range   | 250 mm   |
| maximum range   | 350 mm   |
| angle of beam spread  | please see graphics detection zone   |
| resolution/sampling rate  | 0,069 mm bis 0,098 mm, abhängig vom eingestellten Analogfenster  |
| reproducibility   | ± 0.15 %   |
| accuracy  | ± 1 % (temperature drift internally compensated)   |
| <b>electrical data</b>  |  |
| operating voltage $U_B$   | 10 - 30 V d.c., reverse polarity protection  |
| voltage ripple  | ± 10 %   |
| no-load current consumption   | ≤ 40 mA  |
| type of connection  | 5-pin M12 initiator plug   |

# Ipc-25/CDI/M18

|   |   |
|---|---|
| <b>outputs</b>                            |   |
| output 1                                  | analogue output<br>current: 4-20 mA<br>switchable rising/falling  |
| output 2                                  | switching output<br>pnp: $I_{max} = 200 \text{ mA}$ ( $U_B - 2V$ )<br>NOC/NCC adjustable, short-circuit-proof |
| switching hysteresis                      | 2.0 mm  |
| switching frequency                       | 25 Hz   |
| response time                             | 24 ms   |
| delay prior to availability               | < 300 ms  |
| <b>inputs</b>                             |   |
| input 1                                   | com input<br>teach-in input   |
| <b>housing</b>                            |   |
| material                                  | brass sleeve, nickel-plated, plastic parts, PBT   |
| ultrasonic transducer                     | polyurethane foam, epoxy resin with glass contents  |
| class of protection to EN 60529           | IP 67   |
| operating temperature                     | -25°C to +70°C  |
| storage temperature                       | -40°C to +85°C  |
| weight                                    | 43 g  |
| <b>technical features/characteristics</b> |   |
| temperature compensation                  | yes   |
| controls                                  | com input   |
| scope for settings                        | Teach-in via com input on pin 5<br>LCA-2 with LinkControl   |
| synchronization                           | yes   |
| multiplex                                 | no  |
| indicators                                | 1 x LED yellow: switch status, 1 x LED yellow: object in the window   |
| <b>documentation (download)</b>           |   |
| pin assignment                            |   |

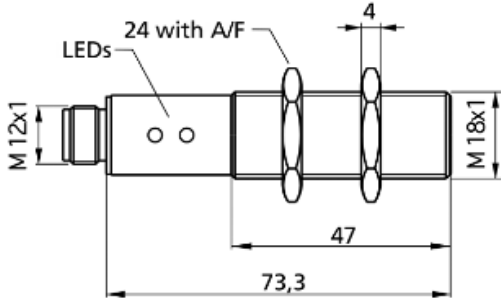
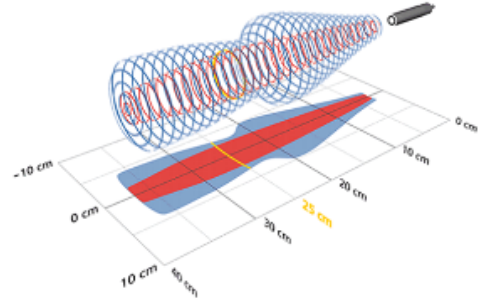
# Ipc-25/CI/M18

| scale drawing   | detection zone  |
|---|---|
|                              |               |
|  <b>1 x analogue 4-20 mA</b> |  <b>350 mm</b> |
| operating range   | 30 - 250 mm   |
| design  | cylindrical M18   |
| operating mode  | analogue distance measurements  |
| <b>ultrasonic -specific</b>   |   |
| means of measurement  | echo propagation time measurement   |
| transducer frequency  | 320 kHz   |
| blind zone  | 30 mm   |
| operating range   | 250 mm  |
| maximum range   | 350 mm  |
| angle of beam spread  | please see graphics detection zone  |
| resolution/sampling rate  | 0,069 mm bis 0,098 mm, abhängig vom eingestellten Analogfenster                                 |
| reproducibility   | ± 0.15 %  |
| accuracy  | ± 1 % (temperature drift internally compensated)  |
| <b>electrical data</b>  |   |
| operating voltage $U_B$   | 10 - 30 V d.c., reverse polarity protection   |
| voltage ripple  | ± 10 %  |
| no-load current consumption   | ≤ 40 mA   |
| type of connection  | 5-pin M12 initiator plug  |

# Ipc-25/CI/M18

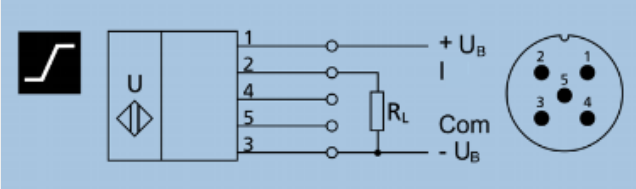
|   |  |
|---|--|
| <b>outputs</b>                            |  |
| output 1                                  | analogue output<br>current: 4-20 mA<br>switchable rising/falling                     |
| response time                             | 24 ms  |
| delay prior to availability               | < 300 ms   |
| <b>inputs</b>                             |  |
| input 1                                   | com input<br>teach-in input  |
| <b>housing</b>                            |  |
| material                                  | brass sleeve, nickel-plated, plastic parts, PBT                                      |
| ultrasonic transducer                     | polyurethane foam, epoxy resin with glass contents                                   |
| class of protection to EN 60529           | IP 67  |
| operating temperature                     | -25°C to +70°C   |
| storage temperature                       | -40°C to +85°C   |
| weight                                    | 43 g   |
| further versions                          | stainless steel<br>high chemical resistance  |
| <b>technical features/characteristics</b> |  |
| temperature compensation                  | yes  |
| controls                                  | com input  |
| scope for settings                        | Teach-in via com input on pin 5<br>LCA-2 with LinkControl                            |
| synchronization                           | yes  |
| multiplex                                 | no   |
| indicators                                | 1 x LED yellow: object in the window   |
| <b>documentation (download)</b>           |  |
| pin assignment                            |  |

# Ipc-25/CU/M18

## scale drawing

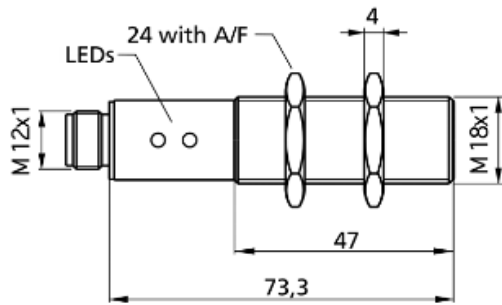

## detection zone

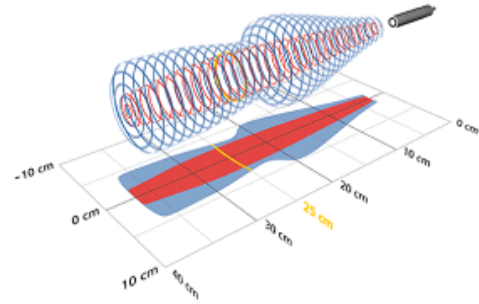

1 x analogue 0-10 V



350 mm

operating range

30 - 250 mm

design

cylindrical M18

operating mode

analogue distance measurements

### ultrasonic -specific

means of measurement

echo propagation time measurement

transducer frequency

320 kHz

blind zone

30 mm

operating range

250 mm

maximum range

350 mm

angle of beam spread

please see graphics detection zone

resolution/sampling rate

0,069 mm bis 0,078 mm, abhängig vom eingestellten Analogfenster

reproducibility

± 0.15 %

accuracy

± 1 % (temperature drift internally compensated)

### electrical data

operating voltage  $U_B$

10 - 30 V d.c., reverse polarity protection

voltage ripple

± 10 %

no-load current consumption

≤ 40 mA

type of connection

5-pin M12 initiator plug



# Ipc-25/CU/M18

|   |  |
|---|--|
| <b>outputs</b>                            |  |
| output 1                                  | analogue output<br>voltage: 0-10 V, short-circuit-proof<br>switchable rising/falling |
| response time                             | 24 ms  |
| delay prior to availability               | < 300 ms   |
| <b>inputs</b>                             |  |
| input 1                                   | com input<br>teach-in input  |
| <b>housing</b>                            |  |
| material                                  | brass sleeve, nickel-plated, plastic parts, PBT                                      |
| ultrasonic transducer                     | polyurethane foam, epoxy resin with glass contents                                   |
| class of protection to EN 60529           | IP 67  |
| operating temperature                     | -25°C to +70°C   |
| storage temperature                       | -40°C to +85°C   |
| weight                                    | 43 g   |
| further versions                          | stainless steel<br>high chemical resistance  |
| <b>technical features/characteristics</b> |  |
| temperature compensation                  | yes  |
| controls                                  | com input  |
| scope for settings                        | Teach-in via com input on pin 5<br>LCA-2 with LinkControl                            |
| synchronization                           | yes  |
| multiplex                                 | no   |
| indicators                                | 1 x LED yellow: object in the window   |
| <b>documentation (download)</b>           |  |
| pin assignment                            |  |