



perfect in sensors.



# POSIMAG®

Magnetic Scale Position Sensors



Contents	Page
POSIMAG® Position Sensors – Overview	3
The company and the products	4
POSIMAG® – the functional principle	5
PMIS3           Magnetic Scale Position Sensors	6
PMIB3           Magnetic Scale	9
PMIB3-ST       Magnetic Scale	10
PMIB3-HT       Magnetic Scale	11
PMIB3/-ST/-HT   Magnetic Scales – Specifications	12
PMIB3/-ST/-HT   Accessories	13
PMIB3/-ST/-HT   Magnetic Scales – Overview	14
Applications for POSIMAG®	15
PMIR4 rotative   Magnetic Wheels and Sensors	16
PMIR4           Magnetic Wheels – Specifications	17
PRODIS-INC       Digital Process Meter for incremental Sensors	20
More ASM Position Sensors: WS – Cable Actuated Position Sensors	24
More ASM Position Sensors: POSICHRON® – Magnetostrictive Position Sensors	26
How to get to ASM	27

The information presented in this catalog does not form part of any quotation or contract, is believed to be accurate and reliable and may be changed without notice. No liability will be accepted by ASM for any consequence of its use. Publication thereof does not convey nor imply any license under patent or industrial or intellectual property rights.

Applications that are described herein for any of these products are for illustrative purpose only. ASM makes no representation or warranty that such applications will be suitable for the specified use without further testing or modification.

Magnetic measuring scale and free floating unguided sensor head

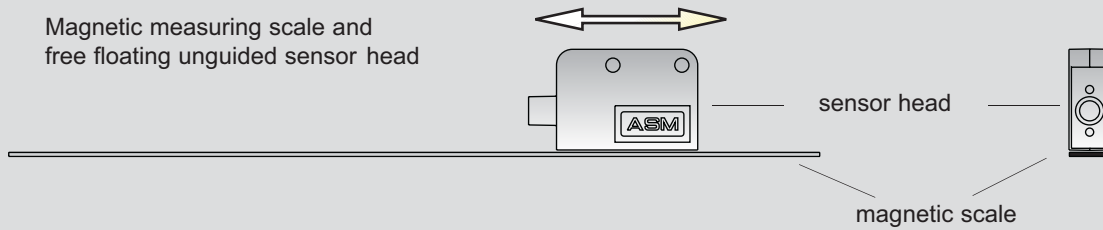

For direct adhesive taping – the cost-effective mounting method

Magnetic measuring scale in flat profile and unguided sensor head

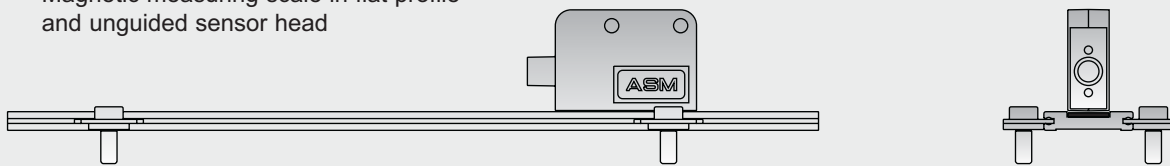

Easy to mount.  
Adjustment on site possible.  
Can be stacked by 3 m units up to 30 m length.

Magnetic measuring scale in guidance profile and guided sensor head

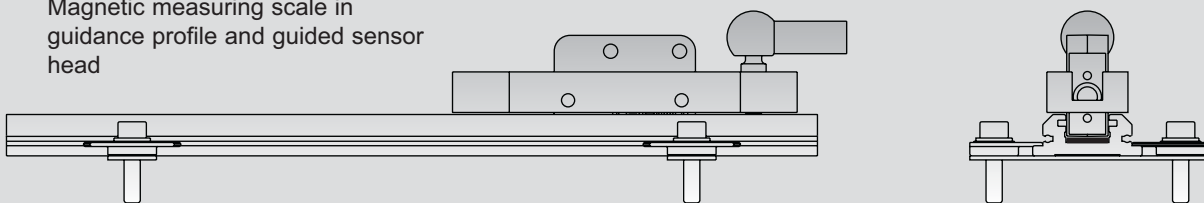

Provides integral linear guidance for applications without own linear guidance by system

Magnetic pole wheels  
POSIMAG-ROT

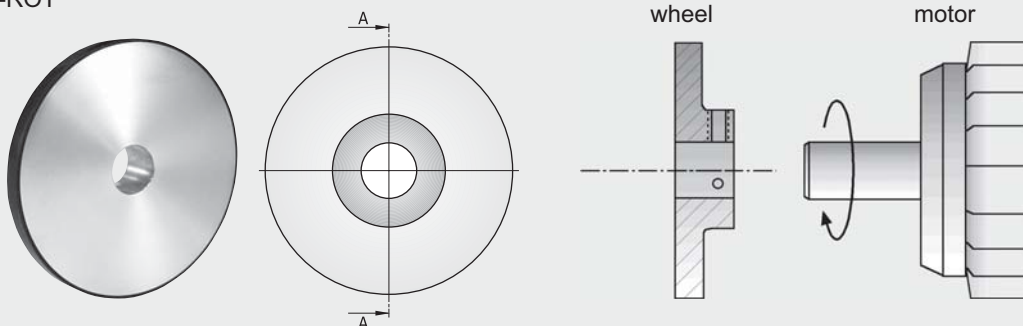

Pole wheels with different diameters are available for angular and/or revolution measurement.



## The company and the products

ASM has played an active role in the manufacture of position sensors for 25 years.

In order to solve all kinds of linear and angular measurement tasks in industry and research, ASM currently offers three different types of positional sensor technology:

- **POSIMAG®**

Magnetic measuring scale with MR sensor head.

Thanks to its special properties, POSIMAG® is ideal for many industrial applications in the production of machinery, plants and precision equipment as well as research. POSIMAG® is suitable for linear, angular and speed measurements. The magnetic scale can also be applied to uneven surfaces.

- **POSICHRON®**

Magnetostrictive principle (Time of Flight).

The areas of application for POSICHRON® positional sensors are wide and varied. They are used in e.g. injection-moulding equipment, dosing and mixing systems, die-casting machines, road vehicle tests, tunnel-boring equipment, wind power plants, patient beds, hydraulic cylinders and presses, fill-level measuring equipment etc.

- **WS**

Cable actuated position sensors.

WS position sensors ensure reliable operation in many sectors of automation, process engineering, industry and research, e.g. in handling systems, circular saws, printing presses, aircraft testing, automobile testing, elevator technology, conveyor belt technology, warehousing technology, local transportation vehicles, tunnel-boring machinery, wind power plants, rehabilitation technology, medical engineering, patient beds, etc.

ASM Position Sensors offer superlative quality and precision. Ongoing research and development in our laboratories, coupled with comprehensive quality management, facilitate and safeguard these high standards.

Position Sensors from ASM are used wherever path, distance, position or length measurements need to be automated, checked, tested or monitored. The customer base includes users from all sectors of government, industry and research.

With around 80 employees at its headquarters in Moosinning near Munich, the company manufactures both standard products and customised, specialist solutions. Thanks to the sales offices in Great Britain, Germany, France and a worldwide network of representatives, sales engineers for ASM products are never far away and will be delighted to demonstrate ASM's range of position sensors at customer premises.



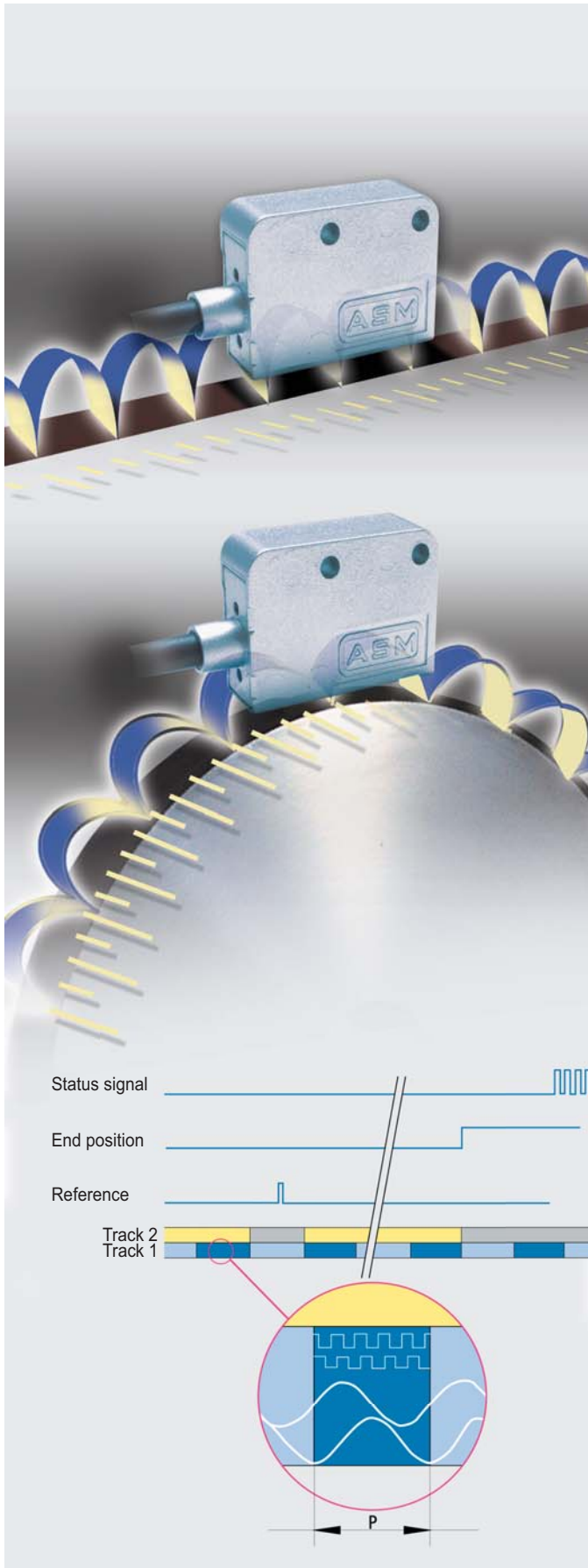

## POSIMAG® – the functional principle

POSIMAG® is a contact-free, high-resolution magnetic position measuring system for measuring lengths of up to approx. 30 metres. Because of its sturdiness and resistance to dirt, together with the system's exceptional resistance to wear and tear, POSIMAG® is also suitable for use under challenging environmental conditions.

POSIMAG® consists of a magnetoresistive (MR) scanning head, and a magnetic measuring scale that consists of a flexible steel strip with a magnetic carrier layer laminated on top. This is magnetised at regular intervals with magnetic north and south poles. The measuring scale can be fastened in position using special adhesive fixing strip or also using pre-produced assembly rails with fastening straps. To protect against external mechanical influences, the magnetic scale has a covering laminate layer made from a thin, stainless steel strip.

To capture a position, the magnetoresistive (MR) sensor head samples sinusoidal magnetic fields above the magnetic measuring scale in such a way that the process is contact-free and avoids wear and tear. The distance of the MR sensor head to the surface of the magnetic scale can be up to 2 mm in the case of a scale with a 5 mm magnetic spacing. The sine-cosine signals generated in the sensor head, which are displaced by 90°, are output without any time delay as RS422-compatible impulse signals via the integrated interpolation electronics working in conjunction with the reference signal. Resolutions of up to 5 µm are available as standard. The signals can then be processed by all common industrial control units with suitable signal processing speeds, or displayed directly using a digital display unit from ASM's PRODIS series.

### Technical advantages:

- Sturdy construction
- Contact-free and wear-free
- Shielded metal housing
- Resistant to dirt
- Protection category up to IP67
- Simple assembly and adjustment
- Signal processing as standard with encoders
- Distance between the MR sensor head and the magnetic scale up to 2 mm
- Reference and terminal position signals
- Measuring lengths of up to 30,000 mm (up to 50 m on request)

# PMIS3 POSIMAG<sup>®</sup> Magnetic Scale Position Sensor



## Very compact sensor for industrial applications Sensor head PMIS3

- Non-contact, no wear
- High velocity
- Robust shielded metal enclosure
- Protection class IP67
- Incremental encoder output A/B/Z
- Signal processing as usual with encoders
- Reference pulse and end position signal
- Indicator for velocity/position errors

A POSIMAG measuring system consists of the sensor head PMIS3 and the magnetic scale PMIB3 with the same magnetic period.

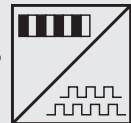

Specifications	Output	
		Incremental encoder output A/B with differential push-pull output, TTL/RS422 or HTL compatible
Excitation voltage	10 ... 30 VDC or 5 VDC ±5 %	
Excitation current	50 mA to 300 mA, depending on pulse frequency, cable length and load	
Magnetic period of the sensor	2 mm	5 mm
Guided spacing between sensor and mag. scale (x <sub>z</sub> )	0.1 ... 0.8 mm	0.1 ... 2 mm
Side tracking tolerance of the sensor	±1 mm	±1 mm
Linearity (sensor with mag. scale PMIB3)	15 µm ± 40 µm/m	30 µm ± 40 µm/m
Repeatability	± 1 digit	
Resolution with ext. times 4 counting mode [µm]	5    10    20    50	10    25    50    125
Max. velocity with fp=50 kHz [m/s] (20 kHz: x 0.4; 10 kHz: x 0.2)	0.8    1.6    3.2    8	1.6    4    8    20

## Order code PMIS3



### Model name

### Magnetic period

20 = 2 mm / 50 = 5 mm

### Resolution (in µm) with times 4 counting mode

Mag. period 2 mm: 5 / 10 / 20 / 50

Mag. period 5 mm: 10 / 25 / 50 / 125

### Max. pulse frequency (in kHz, standard 50 kHz)

50 / 20 / 10

### Output

HTL = HTL output with excitation 24 VDC, output 24 V

TTL = TTL output with excitation 5 VDC, output TTL/RS422

TTL24V = TTL output with excitation 24 VDC, output TTL/10 mA

### Reference pulse/ end position signal/ status signal

Z0 = A/B w/o reference pulse / Z1 = A/B with reference pulse Z

Z2 = A/B with end position signal / \*Z3 = A/B with reference pulse

and status signal

(Option Z3 only for non-differential output, single ended)

### Cable length (in m, standard 2 m)

### Connection

S = Cable output, open end

P = Connector D-sub, 9 pin, at the cable end

**Order example: PMIS3 - 50 - 25 - 50KHZ - HTL - Z1 - 2M - S**

# PMIS3 POSIMAG<sup>®</sup> Magnetic Scale Position Sensor



<b>Specifications</b> (continued)	Max. pulse frequency $f_p$	50 kHz, 20 kHz, 10 kHz (standard 50 kHz)
	Outputs	A, $\bar{A}$ , B, $\bar{B}$ , reference pulse Z, $\bar{Z}$ , end position signal E, $\bar{E}$ , status signal $\bar{ERR}$
	Material of enclosure	Zinc die casting
	Electrical connection	Cable 8 wire, $\varnothing$ 5 mm, open cable end, 9 pin D-sub connector at the cable end as option. Max. length of the integrated sensor cable for TTL: 3 m; HTL/TTL24V: 20 m
	Weight (w/o cable and connector)	30 $\pm$ 5 g
	Protection class (EN 60529)	IP67
	Environmental	
	EMC	DIN EN 61326
	Temperature	-20 ... +85°C



The subsequent counting device must be able to process the specified maximum pulse frequency of the sensor.

<b>Output signals</b>	Saturation voltage	UH, UL = 0,2 V UH, UL = 0,4 V $C_{last} < 10$ nF	$I_{out} = \pm 10$ mA (UH = UB - U <sub>out</sub> ) $I_{out} = \pm 30$ mA
	Short circuit current	ISL, ISH < 800 mA ISL, ISH < 90 mA	(UH, UL = 0 V) (UH, UL = 1,5 V)
	Rise time	$t_r, t_f < 200$ ns	with cable length 1 m, 10 % ... 90 %

<b>Pulse frequency in dependence on the cable length</b>	<b>Load/cable length</b>	<b>Load/pulse frequency <math>f_p</math></b>		
		<b>HTL single ended</b> UB = 24 V	<b>TTL/RS422 differential</b> UB = 5 V *	<b>TTL/24 V</b> UB = 24 V
	Max. output current	50 mA	50 mA	10 mA
	$R_{last}$ min.	500 $\Omega$	100 $\Omega$	500 $\Omega$
	$C_{last}$ max.	10 nF	10 nF	1 nF
	200 m	15 kHz	—	—
	100 m	25 kHz	100 kHz	—
	50 m	50 kHz	200 kHz	50 kHz
	10 m	100 kHz	300 kHz	100 kHz

\* = consider the voltage loss of the cable; the excitation voltage 5 V  $\pm$  5% of the sensor must be guaranteed.

**Note:** For longer distances (see specification above) you must use min. 0,5 mm<sup>2</sup> wire for „Excitation+“ and „Excitation GND“ (see signal wiring next page), all signal wires must be min. 0,14 mm<sup>2</sup>!

## Outline drawing

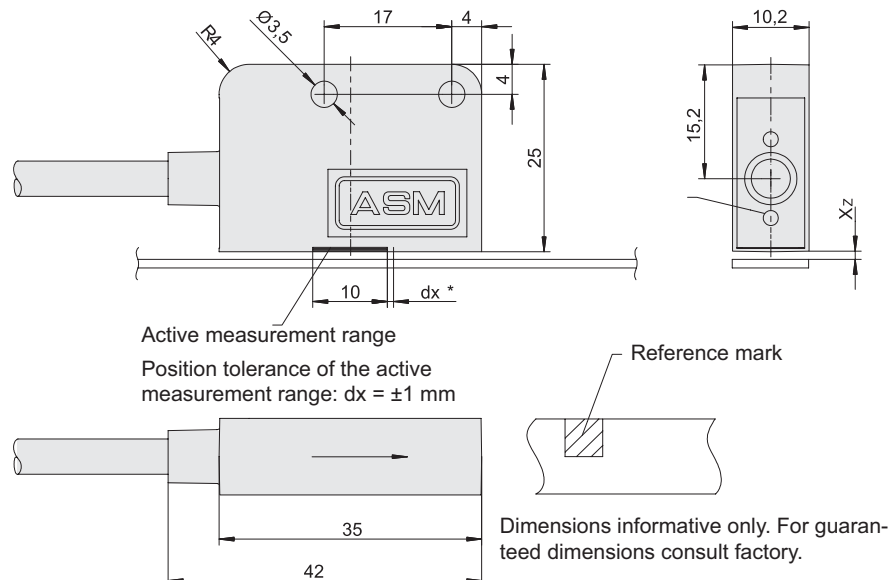

# PMIS3 POSIMAG<sup>®</sup> Magnetic Scale Position Sensor



## Output signals

### Option Z1 (Reference pulse)

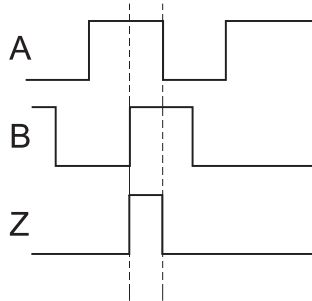

### Option Z2 (End position signal)

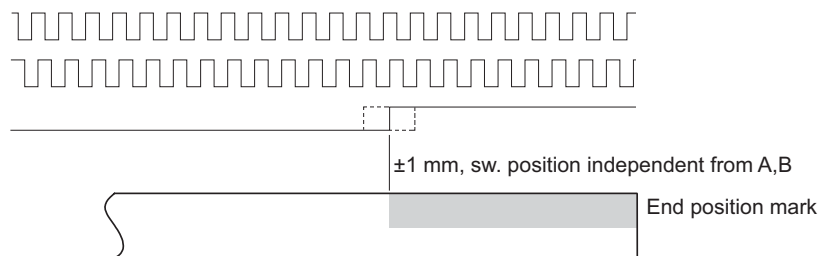

Signal wiring / connection	Signal name					Open cable end Cable colour	Conn. D-sub, 9 pin pin no.
	Option	Z0	Z1	Z2	Z3*		
	Excitation +					white	1
	Excitation GND (0V)					brown	5
		B	B	B	B	green	2
		A	A	A	A	yellow	3
		$\overline{B}$	$\overline{B}$	$\overline{B}$	$\overline{ERR}$	grey	7
		$\overline{A}$	$\overline{A}$	$\overline{A}$	-	pink	6
		-	Z	$\overline{E}$	Z	blue	4
		-	$\overline{Z}$	E	-	red	8
	Shield					black	9

Z = reference pulse  
 E = end position signal  
 ERR = status signal, periodical approx. 16 Hz, for side tracking and velocity errors  
 \* = status signal  $\overline{ERR}$  available only with HTL (single ended) output

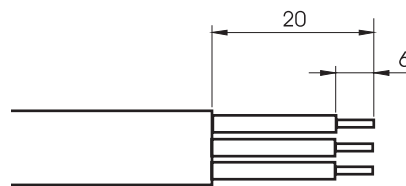

Cable output dimensions

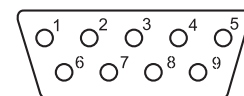

Connector D-sub (Pin)  
View to connector pins



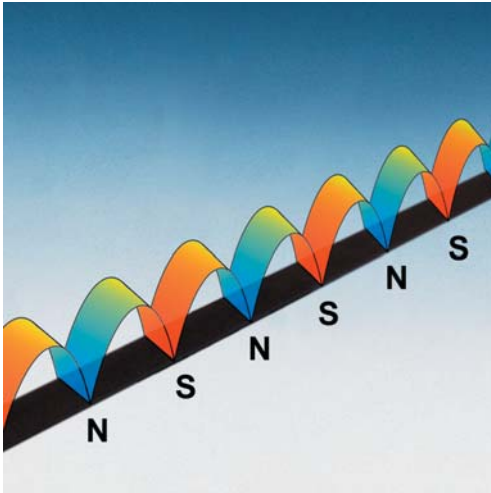

## Magnetic scale PMIB3 for Position Sensor PMIS3

- **Easy splicing**
- **Resistant to moisture and many fluids**
- **Extensive ruggedness against dust etc.**

The magnetic material is magnetised in defined and even distances and works as a solid measure. Reference marks can be user defined in 4 mm resp. 10 mm steps. The magnetic scale retains its firmness by means of a spring steel base (standard steel strip CK 85).

Specifications		Solid measure	
		Plastic bonded flexible permanent magnet	
Base material		Spring steel CK 85	
Masking tape		Stainless steel (non magnetic)	
Measurement ranges		e.g. 100 ... 2500 mm (up to 50 m on request)	
Width		10 mm +0.1 mm / -0.2 mm	
Thickness (with masking tape)		1.7 mm ±0.1 mm	
Magnetic period		2 mm	5 mm
Linearity at 25°C	up to 30 m	±40 µm/m	±40 µm/m
	up to 50 m	±80 µm/m	±80 µm/m
Reference mark (reference pulse)		max. every 4 mm	max. every 10 mm
Measurement range		must be divisible by 4	must be divisible by 10
Linear thermal expansion coefficient		11 x 10 <sup>-6</sup> / K	
Operating temperature		-10 ... +70°C	

An unmagnetic masking tape made of stainless steel is available (accessories). The magnetic scale is flexible and can be glued to the surface of a cylinder with a minimum radius of 100 mm and used for angular measurements.

## Order code PMIB3



### Model name

### Magnetic period

20 = 2 mm / 50 = 5 mm

### Mounting of the magnetic scale

N = adhesive taping

### Measurement range (total length = range + X mm, refer to the table on page 12)

e.g. 100, 500, 1000 ... 2500 mm (up to 50 m on request)

Measurement ranges must be divisible by 4 (resp. by 10)

### Reference marks/end position marks (optional)

R1 = reference mark on the left / R2 = on the right

E1 = end position mark on the left / E2 = on the right

Additional reference marks every 4 mm (period 2 mm) resp. 10 mm (period 5 mm) from the left

### Options

FP = magnetic scale in flat profile

HP = magnetic scale in high profile

AB = Masking tape (only with FP or HP)

**Order example: PMIB3 - 50 - N - 1500 - R1**

# PMIB3-ST POSIMAG<sup>®</sup> Magnetic Scale

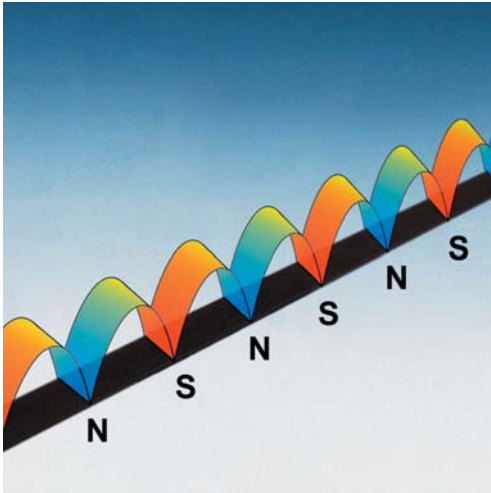

## Magnetic scale PMIB3-ST for Position Sensor PMIS3

- Easy splicing
- Resistant to moisture and many fluids
- Extensive ruggedness against dust, chipping etc.
- Magnetic scale with stainless steel base

The magnetic material is magnetised in defined and even distances and works as a solid measure. Reference marks can be user defined in 4 mm resp. 10 mm steps. The magnetic scale retains its firmness by means of a spring steel base (stainless steel strip CrNi 17 7).

Specifications		Solid measure	
		Plastic bounded flexible permanent magnet	
Base material		Stainless steel CrNi 17 7 / PE	
Masking tape		Stainless steel (non magnetic)	
Measurement ranges		e.g. 100 ... 2500 mm (up to 50 m on request)	
Width		10 mm +0.1 mm / -0.2 mm	
Thickness (with masking tape)		1.7 mm ±0.1 mm	
Magnetic period		2 mm	5 mm
Linearity at 25°C	up to 30 m	±40 µm/m	±40 µm/m
	up to 50 m	±80 µm/m	±80 µm/m
Reference mark (zero pulse)		max. every 4 mm	max. every 10 mm
Measurement range		must be divisible by 4	must be divisible by 10
Linear thermal expansion coefficient		11 x 10 <sup>-6</sup> / K	
Operation temperature		-10 ... +70°C	

An unmagnetic masking tape made of stainless steel is available (accessories). The magnetic scale is flexible and can be glued to the surface of a cylinder with a minimum radius of 100 mm and used for angular measurements.

## Order code PMIB3-ST



### Model name

### Magnetic period

20 = 2 mm / 50 = 5 mm

### Mounting of the magnetic scale

N = adhesive taping

### Measurement range (total length = range + X mm, refer to the table on page 12)

e.g. 100, 500, 1000 ... 2500 mm (up to 50 m on request)  
Measurement ranges must be divisible by 4 (resp. by 10)

### Reference marks/end position marks (optional)

R1 = reference mark on the left / R2 = on the right

E1 = end position mark on the left / E2 = on the right

Additional reference marks every 4 mm (period 2 mm) resp. 10 mm (period 5 mm) from the left

### Options

FP = magnetic scale in flat profile

HP = magnetic scale in high profile

AB = masking tape (only with FP or HP)

**Order example: PMIB3-ST - 50 - N - 1500 - R1**

# PMIB3-HT POSIMAG<sup>®</sup> Magnetic Scale

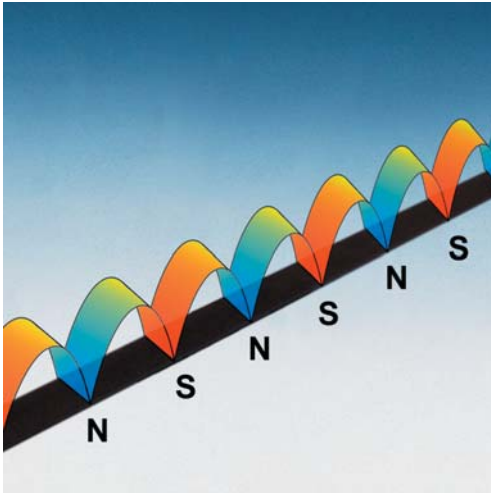

## Magnetic scale PMIB3-HT for Position Sensor PMIS3

- Easy splicing
- Resistant to moisture and many fluids
- Extensive ruggedness against dust etc.
- High temperature durability
- Magnetic scale with stainless steel base

The magnetic material is magnetised in defined and even distances and works as a solid measure. Reference marks can be user defined in 4 mm resp. 10 mm steps. The magnetic scale retains its firmness by means of a spring steel base (stainless steel strip CrNi 17 7).

Specifications		Solid measure	
		Plastic bonded flexible permanent magnet	
Base material		Stainless steel CrNi 17 7 / elastomer	
Masking tape		Stainless steel (non magnetic)	
Measurement ranges		e.g. 100 ... 2500 mm (up to 50 m on request)	
Width		10 mm +0.1 mm / -0.2 mm	
Thickness (with masking tape)		1.7 mm ±0.1 mm	
Magnetic period		2 mm	5 mm
Linearity at 25°C	up to 30 m	±40 µm/m	±40 µm/m
	up to 50 m	±80 µm/m	±80 µm/m
Reference mark (reference pulse)		max. every 4 mm	max. every 10 mm
Measurement range		must be divisible by 4	must be divisible by 10
Linear thermal expansion coefficient		11 x 10 <sup>-6</sup> / K	
Operating temperature		-20 ... +120°C	

An unmagnetic masking tape made of stainless steel is available (accessories). The magnetic scale is flexible and can be glued to the surface of a cylinder with a minimum radius of 100 mm and used for angular measurements.

## Order code PMIB3-HT



### Model name

### Magnetic period

20 = 2 mm / 50 = 5 mm

### Mounting of the magnetic scale

N = adhesive taping

### Measurement range (total length = range + X mm, refer to the table on page 12)

e.g. 100, 500, 1000 ... 2500 mm (up to 50 m on request)

Measurement ranges must be divisible by 4 (resp. by 10)

### Reference marks/end position marks (optional)

R1 = reference mark on the left / R2 = on the right

E1 = end position mark on the left / E2 = on the right

Additional reference marks every 4 mm (period 2 mm) resp. 10 mm (period 5 mm) from the left

### Options

FP = magnetic scale in flat profile

HP = magnetic scale in high profile

AB = masking tape (only with FP + HP)

**Order example: PMIB3-HT - 50 - N - 1500 - R1**

# PMIS3/ PMIB3/-HT/-ST POSIMAG® Magnetic Scale



## Position of the standard reference marks

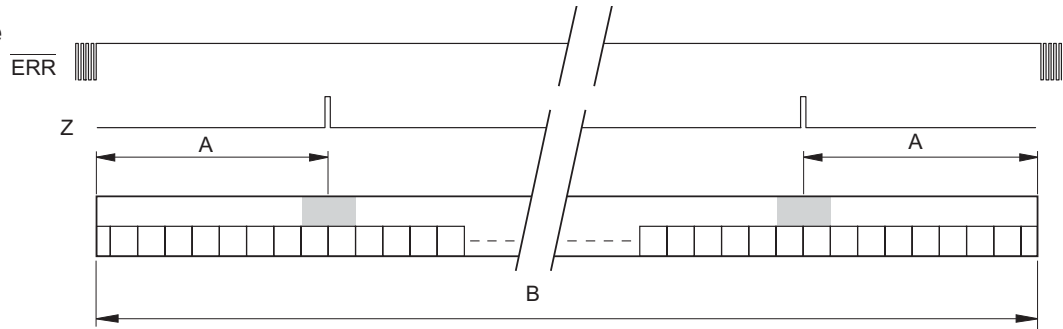

Dimensions reference	Magnetic period	Switching position A	Total length B
	2 mm	20.0 ±1 mm	measurement range + 40 mm
	5 mm		
	2 mm with high profile	60.0 ±1 mm	measurement range + 120 mm
	5 mm with high profile		

Additional reference marks every 4 mm (period 2 mm) resp. 10 mm (period 5 mm) from the left h. s.

## Position of the end position marks

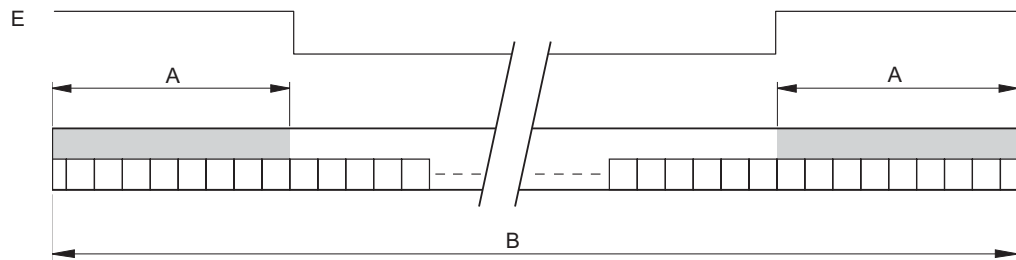

Dimensions end positions	Magnetic period	Switching position A	Total length B
	2 mm	21.0 ±1 mm	measurement range + 50 mm
	5 mm	22.5 ±1 mm	measurement range + 50 mm
	2 mm with high profile	61.0 ±1 mm	measurement range + 130 mm
	5 mm with high profile	62.5 ±1 mm	measurement range + 130 mm

# PMIS3/PMIB3 POSIMAG®

## Magnetostrictive Position Sensor

### Accessories



#### Masking tape PMAB:

Masking tape made of stainless steel for POSIMAG magnetic scale PMIB3, width 10 mm, thickness 0.2 mm

Order code: PMAB — 10MM —     
 Length in mm

#### Outline drawing flat profile PMFP

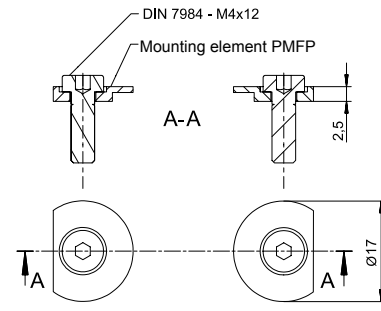
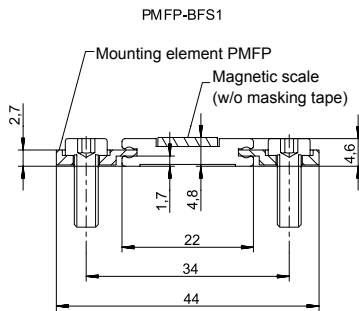

Mounting set PMFP-BFS1

#### Outline drawing high profile PMHP

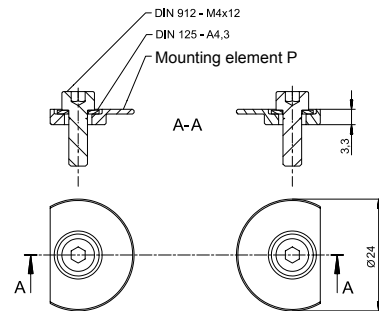
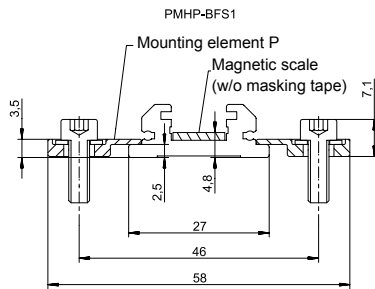

Mounting set PMHP-BFS1

#### Slider for high profile PMGW3

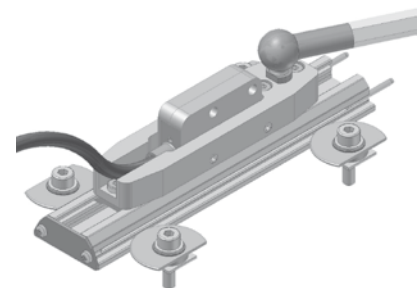
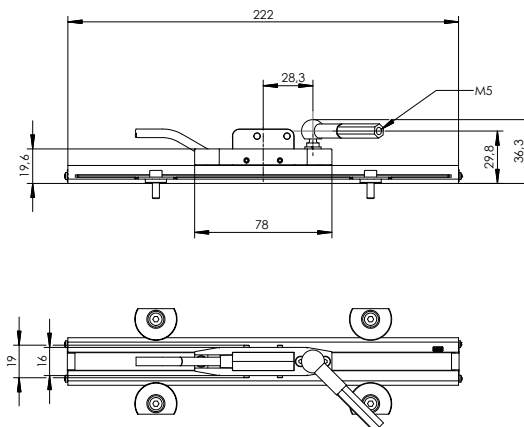

Dimensions informative only. For guaranteed dimensions consult factory.

**Magnetic Scales – Technical Information**

**Types of magnetic scales / Application recommendation**

Type	Standard scale PMIB3	Stainless steel scale PMIB3-ST	Stainless steel elastomer scale PMIB3-HT
base strip	CK 85 stainless steel	CrNi 17 7 stainless steel	CrNi 17 7 stainless steel
magnetic scale	PE magnetic scale	PE magnetic scale	Elastomer magnetic scale
environmental conditions	normal	difficult	very difficult
corrosion resistance	normal	high	high
temperature resistance	normal	normal	high
media resistance	normal	normal	high

**Chemical durability – PE magnetic scales (PMIB3, PMIB3-ST)**

no / little influence	weak / middle influence	strong influence
some mineral oils vegetable oils methyl / isopropanol weak organic acids formaldehyde	anhydrous ammonia acetylene benzine kerosene steam, vapour acetic acid 20% / 30% sea water oleic acid	benzene nitrobenzene paint solvents turpentine nitric acid 70% hydrochloric acid 37% toluene xylene tetrachloromethane trichloroethylene

**Chemical durability – Elastomer magnetic scales (PMIB3-HT)**

no / little influence	weak / middle influence	strong influence
motor oils gear oils ATF (automatic transmission fluid) hydraulic fluid kerosene antifreeze agent purifying agent turpentine water sea water/salt water	JP-4 fuel (Jet fuel) gasoline/petrol heptane alcohol	aromatic hydrocarbon (benzene, toluene, xylene) ketone anorganic acids (HCl, H <sub>2</sub> SO <sub>4</sub> )

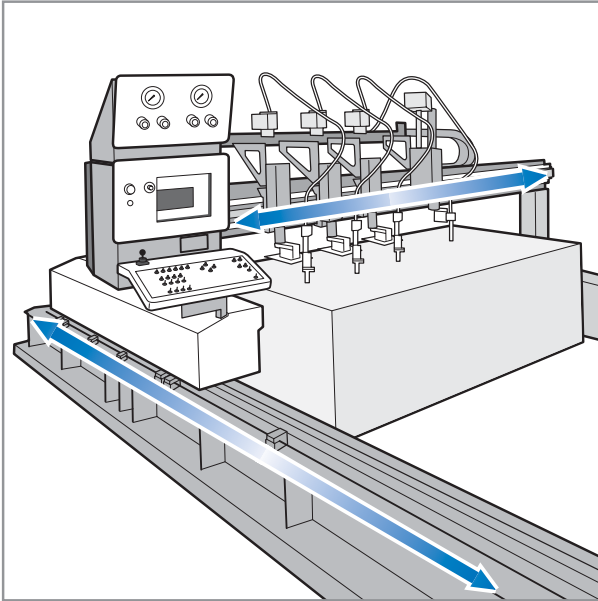

Flame cutting machines

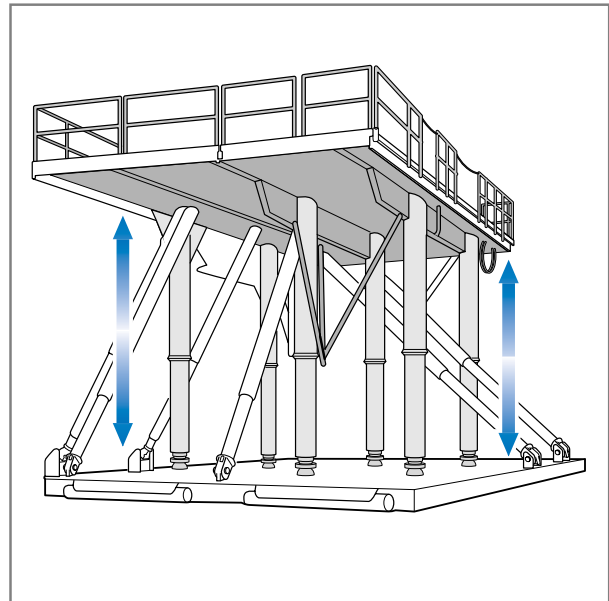

Huge lifting platforms

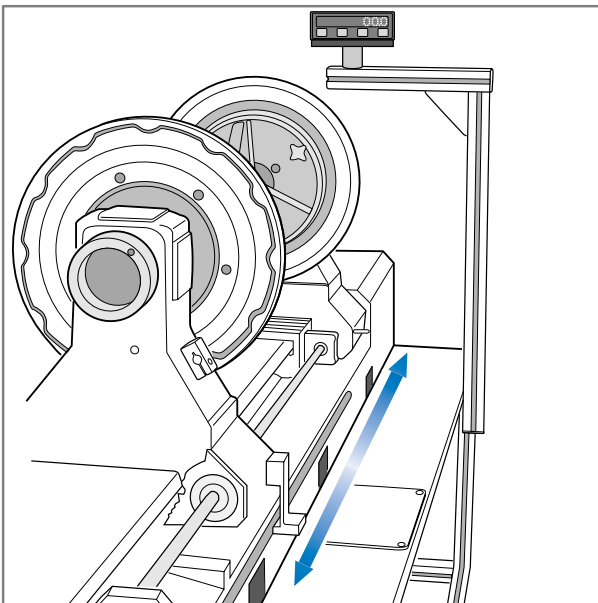

Special gear lathes

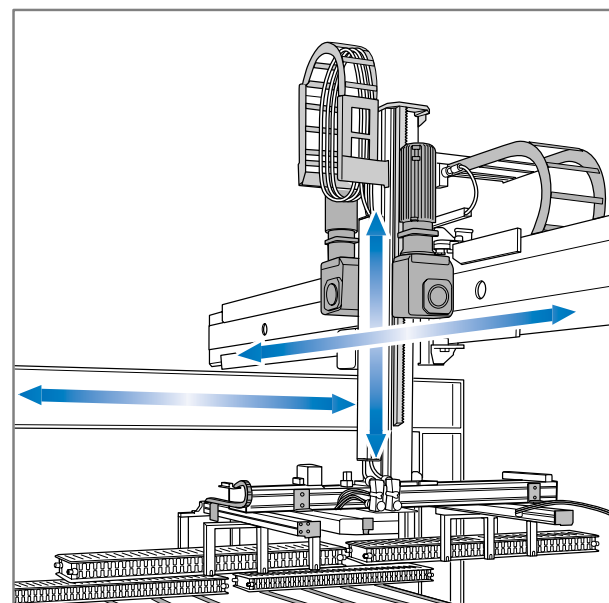

X/Y/Z surveyor's transits

# PMIS4, PMIR4 POSIMAG® rotative Magnetic Wheels and Sensors



## Magnetic wheels for rotative applications with POSIMAG® Position Sensor PMIS4

- Resistant against shock, vibration, humidity and many liquids
- Robust against dust, swarf
- Multiple diameters and resolutions
- With aluminium carrier

A wheel made of plastic bonded magnetic material is magnetised in defined and even distances. An optional index mark generates an index pulse which occurs once in a rotation. A multitude of diameters, resolutions and mechanical integrations with and without aluminium carrier is available.

### Order code wheel PMIR4

	PMIR4 - [ ] - [ ] - [ ] - [ ]
<b>Model name</b>	_____
<b>Magnetic period</b> 20 = 2 mm / 50 = 5 mm	_____
<b>Number of poles</b> 50, 64, 90 / further pole numbers on request	_____
<b>Index pulse</b> O = without / M = with	_____
<b>Inside diameter</b> 20 = 20H7 / further diameters on request	_____

### Order code sensor PMIS4

(refer to specifications of PMIS3)

	PMIS4 - [ ] - [ ] - [ ] KHZ - [ ] - [ ] - [ ] M - [ ]
<b>Model name</b>	_____
<b>Magnetic period</b> 20 = 2 mm / 50 = 5 mm	_____
<b>Scaling factor</b> refer to the table on page 17	_____
<b>Max. pulse frequency (in kHz, standard 50 kHz)</b>	_____
<b>Output</b> HTL = HTL output with excitation 24 VDC, output 24 V TTL = TTL output with excitation 5 VDC, output TTL/RS422 TTL24V = TTL output with excitation 24 VDC, output TTL/10 mA	_____
<b>Index pulse / status signal</b> Z0 = A/B w/o index pulse / Z1 = A/B with index pulse Z Z3 = A/B with index pulse and status signal, only for non-differential output, single ended	_____
<b>Cable length (in m, standard 2 m)</b>	_____
<b>Connection</b> S = open cable end P = connector D-sub 9 pin, at the cable end	_____

**Order example wheel: PMIR4 - 20 - 50 - O - 20**

**Order example sensor: PMIS4 - 20 - 100 - 50KHZ - HTL - Z0 - 2M - S**



# PMIR4 POSIMAG®

## Magnetic Wheels – Specifications



<b>Specifications</b>	Material	Plastic bonded magnetic material or magnetic scale
	Base material	Aluminium
	Signal periods per rotation	from 20 periods/rotation
	Magnetic period	2 mm, 5 mm
	Temperature range	-30 ...+120°C
	Linearity with the sensor PMIS4	approx. ± 0.1°

Data valid in connection with the sensor PMIS4.

A multitude of diameters, resolutions and mechanical integrations with and without aluminium carrier is available.

### Standard magnetic wheels

Type	Poles	∅	Altitude	Signal periods/rotation	Inside diameter
PMIR4-20-50	50	31.8	18	decade division (refer to the table below)	20H7
PMIR4-20-64	64	40.7	18	binary division (refer to the table below)	20H7
PMIR4-20-90	90	57.3	18	vernier (refer to the table below)	20H7

Further pole numbers, diameters and magnetic periods on request.

Scaling factor Sensor PMIS4-20- ...	PMIR4-20-50		PMIR4-20-64		PMIR4-20-90	
	Signal periods	RPM )*	Signal periods	RPM )*	Signal periods	RPM )*
1	50	6000	64	6000	90	6000
2	100	6000	128	6000	180	6000
4	200	6000	256	6000	360	6000
8	400	6000	512	6000	720	6000
10	500	5760	640	4500	900	3200
16	800	6000	1024	6000	1440	6000
20	1000	5760	1280	4500	1800	3200
25	1250	6000	1600	6000	2250	5120
32	1600	6000	2048	6000	2880	6000
40	2000	5760	2560	4500	3600	3200
50	2500	6000	3200	6000	4500	5120
64	3200	6000	4096	5625	5760	4000
80	4000	5760	5120	4500	7200	3200
100	5000	4608	6400	3600	9000	2560
125	6250	3686	8000	2880	11 250	2048
128	6400	3600	8192	2813	11 520	2000
200	10 000	2304	12 800	1800	18 000	1280
250	12 500	1843	16 000	1440	22 500	1024
256	12 800	1800	16 384	1406	23 040	1000
400	20 000	1152	25 600	900	36 000	640
500	25 000	922	32 000	720	45 000	512
512	25 600	900	32 768	703	46 080	500
1024	51 200	450	65 536	352	92 160	250
2048	102 400	225	131 072	176	184 320	125

)\* Maximum revolution per minute mechanically 6.000 RPM

# PMIR4 POSIMAG<sup>®</sup> Magnetic Wheels



## Outline drawing

PMIR4-20-50

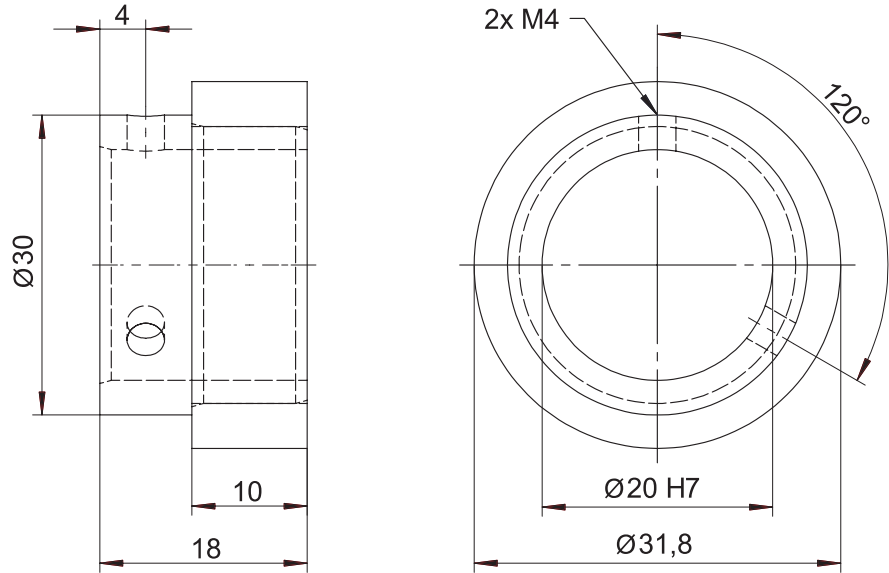

PMIR4-20-64

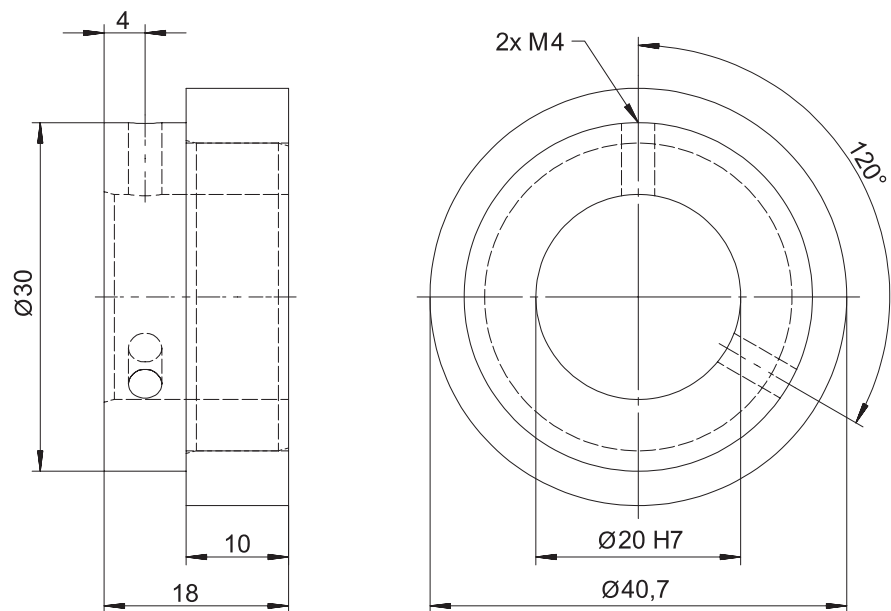

# PMIR4 POSIMAG® Magnetic Wheels



## Outline drawing

PMIR4-20-90

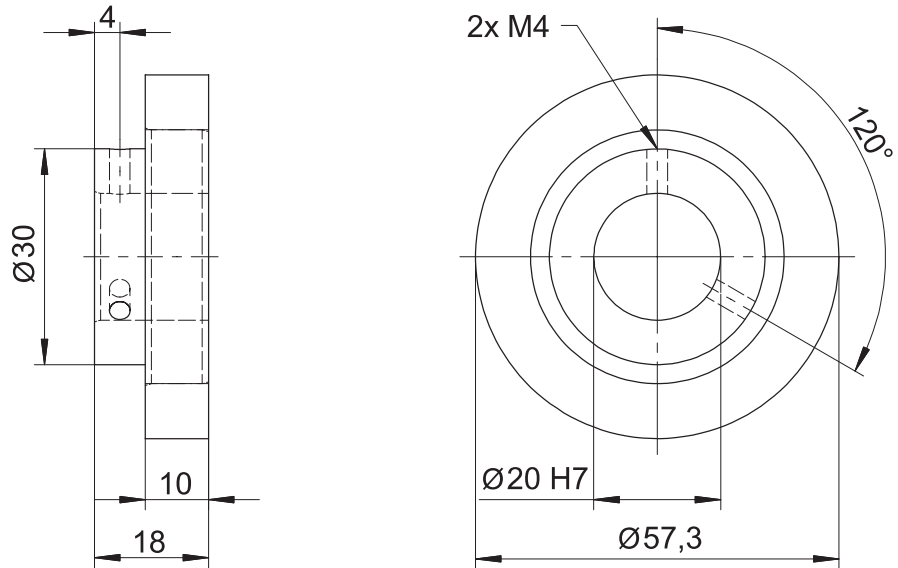

Dimensions informative only. For guaranteed dimensions consult factory!

# PRODIS-INC

## Digital Process Meter

### for Incremental Sensors



#### For POSIMAG® and all ASM Position Sensors and Encoders with incremental output

- Integrated sensor supply
- Counting rate up to 250 KHz (<1 MHz edge freq.)
- 6-digit LED display
- Relative measurement mode
- RS-232 interface
- Optional 4 comparator outputs

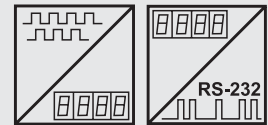

#### Description

PRODIS-INC is designed for use with incremental position sensors to display angles and displacements. The fast counter processes 90° phase shifted A,B signals (quadrature signals) for direction and counting information. Sensor excitation is supplied from the meter. With four membrane keys all parameters can be programmed for the special application. A zero signal and a reference signal can be used for calibration of the measurement system. Optional comparator functions with 4 NPN open-collector outputs are available, 2 of them also as relay output.

Specifications		
Display		6-digit 7-segment LED, 14 mm high, decimal point programmable
Excitation voltage/current		24 VDC ±10%/150 mA, 85-250 VAC/180 mA max.
Counting rate		250 kHz maximum, 1 MHz edge frequency
Sensor excitation		24 VDC/200 mA or 5 VDC/200 mA
Inputs		A, B, Z, T (reference signal)
Connection		Terminal strip 12-pole, excitation 3-pole
Operation temperature		-10 to +40 °C
Storage temperature		-20 to +85 °C
Weight		approx. 250 g
Protection class		Front IP60, back IP40
Humidity		Max. 95% rh, non condensing
Comparator outputs (option)	Relay NPN	250 VAC/5 A, 30 VDC/5 A 24 V max./50 mA to GND
Safety of equipment		Directive 73/23/EWG: DIN EN 61010:1994-03
Electromagnetic compatibility		Directive 89/336/EWG

#### Order code PRODIS-INC

##### Model name

##### Excitation voltage

24VDC = 24 VDC

230VAC = 85 ... 250 VAC

##### Sensor Excitation Voltage

G24V = 24 VDC

G5V = 5 VDC

##### Sensor signal

HTL = HTL level with excitation voltage G24V

TTL = TTL level with excitation voltage G5V or G24V

##### Comparator (option)

REL2

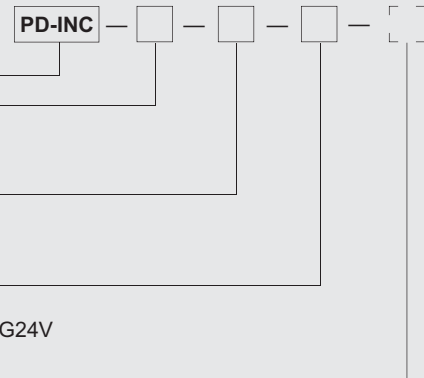

**Order example: PD - INC - 24VDC - G24V - HTL**

# PRODIS-INC

## Digital Process Meter

### for Incremental Sensors



<b>Programmable Parameters / Value Range</b>	Value range display, offset, limit values	-999999 to +999999
	Divisor, multiplier	0 to 999999
	Other programmable parameters	Counting direction, decimal point position, last-value memory, Z signal evaluation, display brightness
	Signal-T	Manual zero, key lock, display value hold, Z release, relative measurement

<b>Wiring basic equipment</b>	<b>Signals</b>	<b>Connector X1 pin no.</b>	<b>Connector X2 pin no.</b>
	Sensor +UB	1	
	Sensor 0 V (GND)	2	
	Signal A	4	
	Signal $\bar{A}$	5	
	Signal B	6	
	Signal $\bar{B}$	7	
	Signal Z (zero signal)	8	
	Signal $\bar{Z}$ (zero signal)	9	
	Signal T (reference signal)	10	
	Signal $\bar{T}$ (reference signal)	11	
	GND	12	
	PD-INC-24VDC: Excitation +24 V Excitation 0 V		13 14
	PD-INC-230VAC: Excitation Protective ground		13 / 15 14

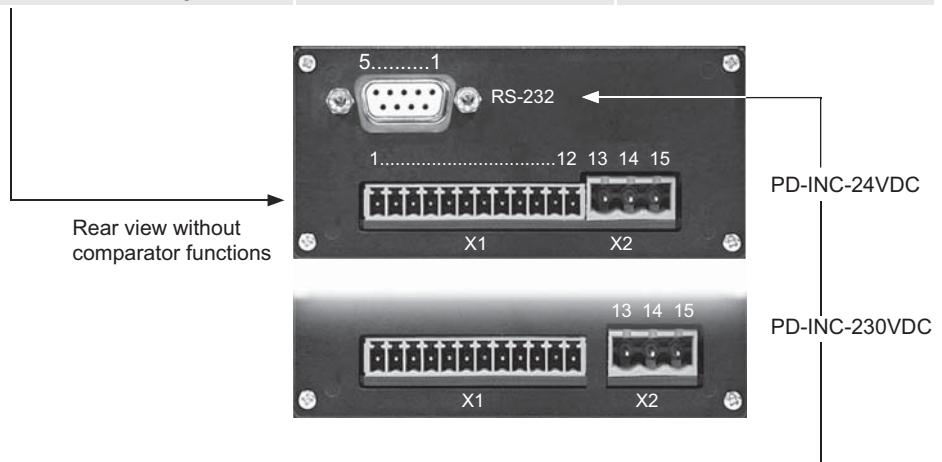

<b>RS-232-Interface</b>	Level	RS-232: $\pm 8$ V, galvanically isolated	
	Data format	1 start bit, 8 data bits, 1 stop bits, no parity	
	Transmission rate	4800 / 9600 / 19200 Baud	
	<b>Signals</b>	<b>Connector X3 pin no.</b>	<b>D-SUB pin no.</b>
	TxD	17	2
	RxD	16	3
	GND	18	5

# PRODIS-INC

## Digital Process Meter

### for Incremental Sensors



Rear view with comparator functions

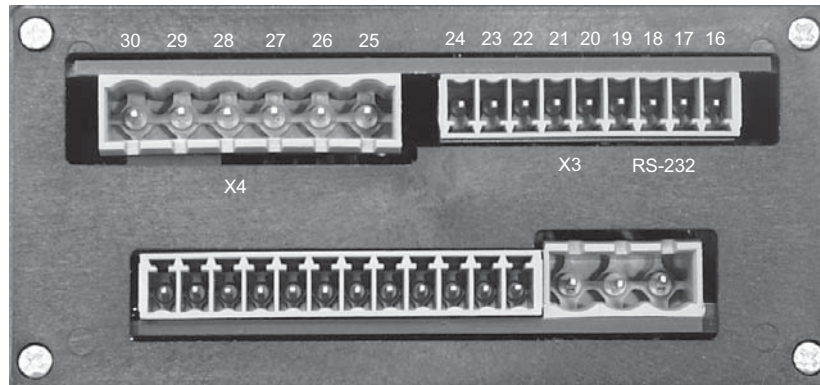

Comparator function (option)	Comparator function	Comparator output			
		NPN collector	Connector X3 Pin	Relay	Connector X4 Pin
Comparator 1	NPN1	20	relay1 normally closed contact	25	LED1
			normally opened contact common	27 26	
Comparator 2	NPN2	21	relay2 normally closed contact	28	LED2
			normally opened contact common	30 29	
Comparator 3	NPN3	22			
Comparator 4	NPN4	23			
	NPN GND	24			
	NPN U <sub>B</sub> (+24V)	19			

Zero signal Z and reference signal T

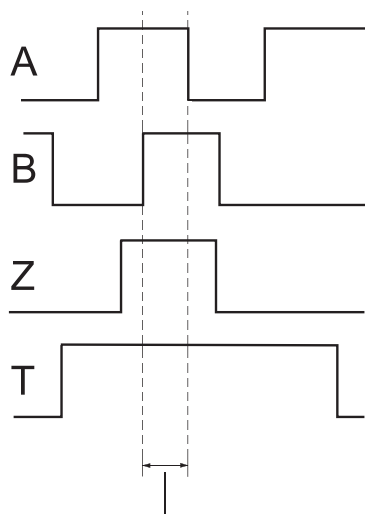

Valid range ( A & B & Z ) resp. ( A & B & Z & T )

# PRODIS-INC

## Digital Process Meter

### for Incremental Sensors



#### Outline drawing

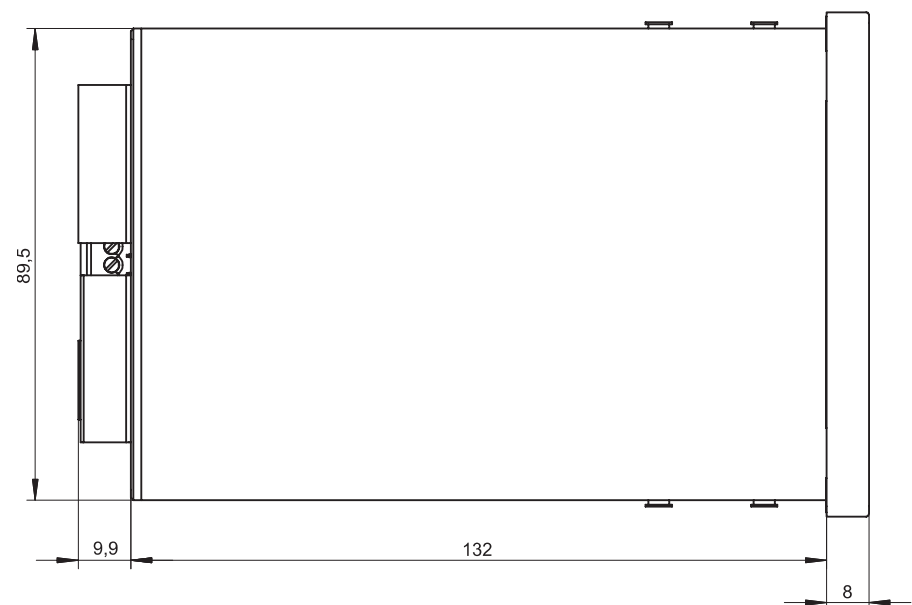
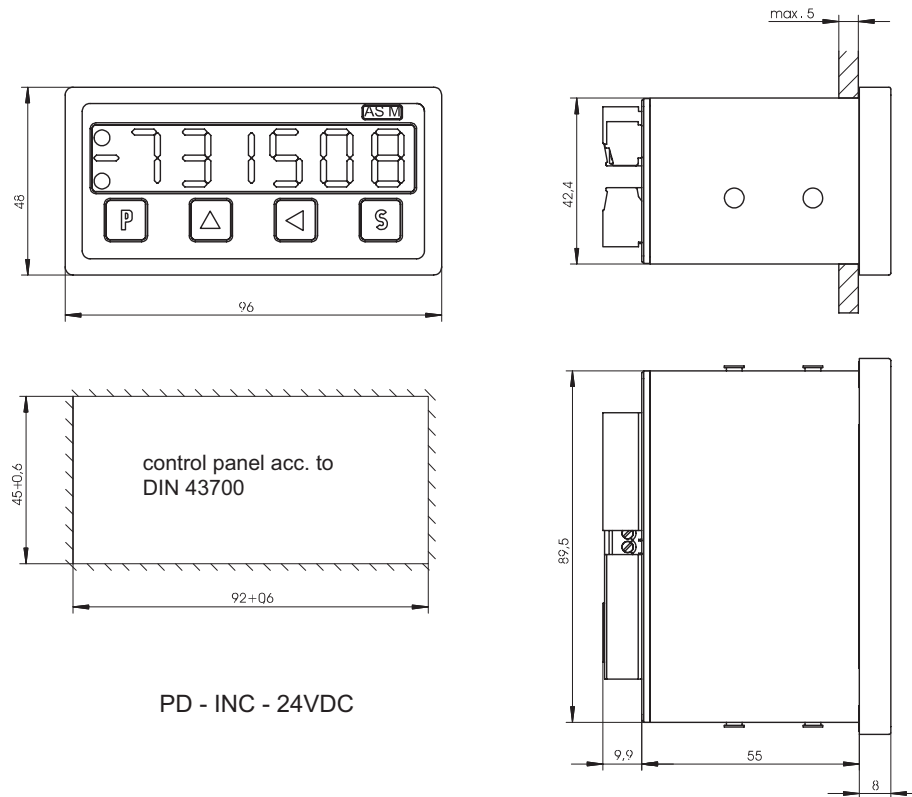

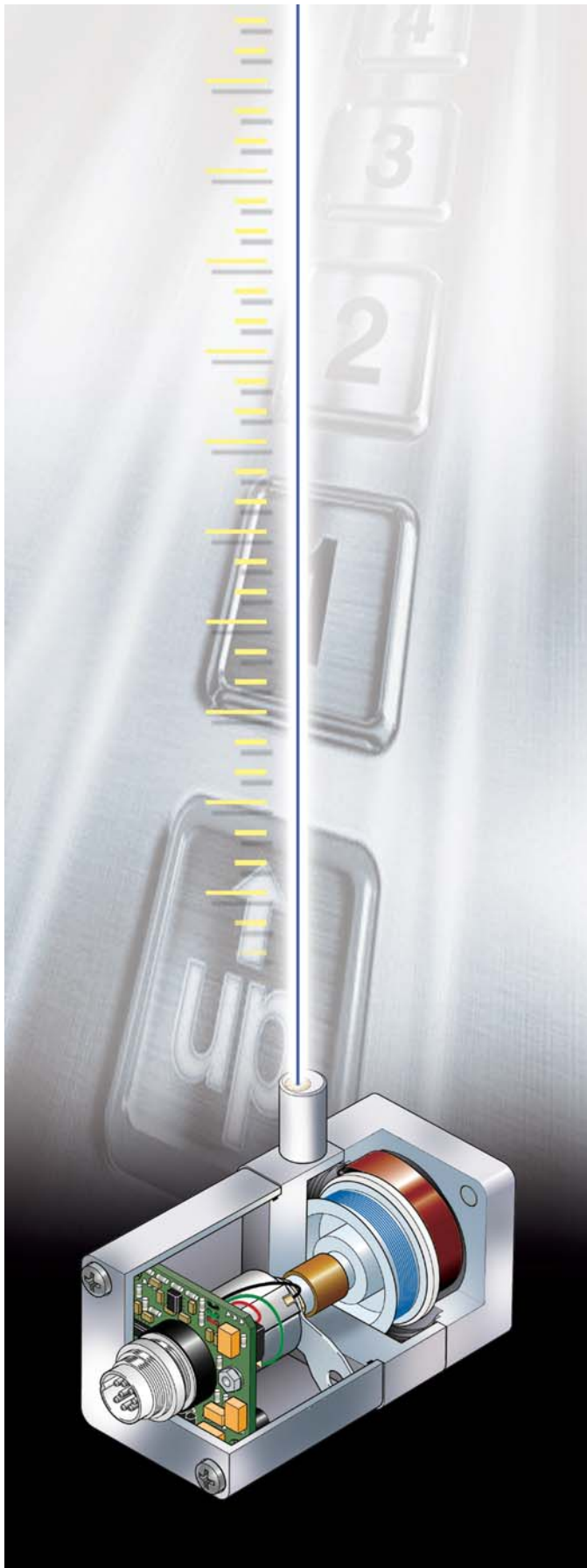

### WS Position Sensors – the functional principle

WS position sensors capture position measurement either absolutely or incrementally, using measuring cables made from stainless steel. Using different constructions, and with measuring lengths of up to 60,000 mm, the ultra-simple, sturdy, space-saving designs make these sensors the ideal basic solution for many length and positional measuring tasks.

WS position sensors comprise the following components:

- A precisely-calibrated measuring cable
- A measuring cable drum
- A measurement shaft
- A spring motor
- An angle sensor element
- Optional sensor electronics.

The measuring cable is first wound in tight spiral layers round the drum. To determine the position, the measuring cable is then unwound from the drum against the return force of the spring motor. The unwinding process from the drum converts the linear movement of the measuring cable into an angular movement. This angular movement is then captured using angle sensor elements (encoders or potentiometers) and converted into an electrical output signal.

Analogue output types include potentiometer, 0-10 V, 4-20 mA, analogue derived SSI or a programmable version with span and offset adjustment. Digital outputs include incremental encoder, absolute encoder, SSI, CANopen, Profibus, Interbus-S or RS-232.

#### Technical advantages:

- Fast and easy to assemble
- Only minimal linear guidance required
- Compact design
- Resistant to vibration and shock
- High protection category to IP67
- Linearity of up to 0.01%
- High measuring speed up to 20 m/s
- Measuring lengths of up to 60,000 mm
- Many output types



# Applications for WS Position Sensors

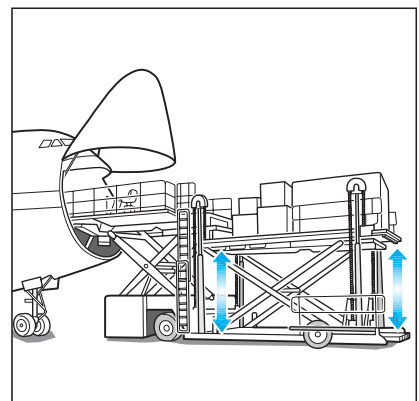
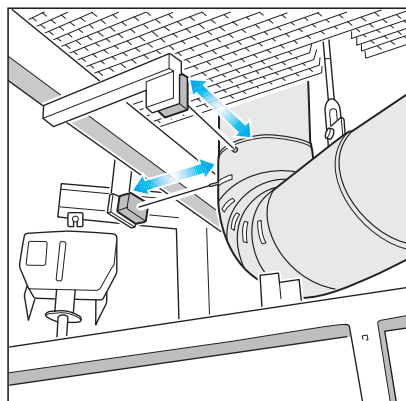
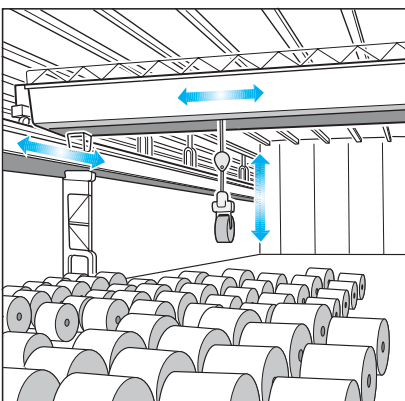
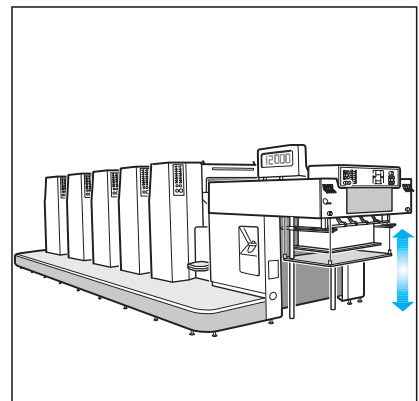
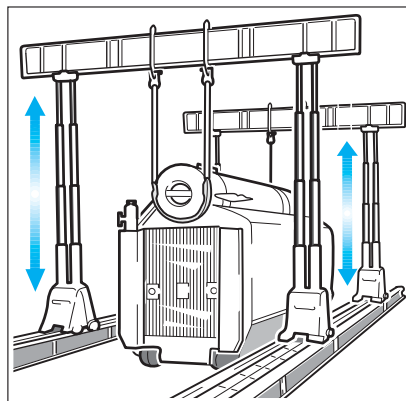
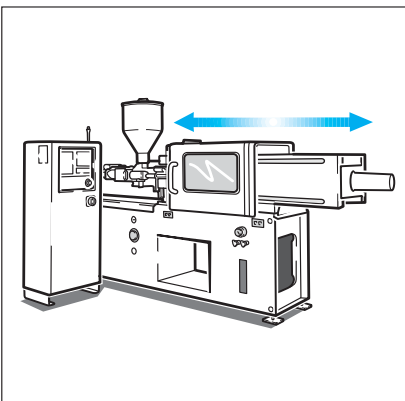
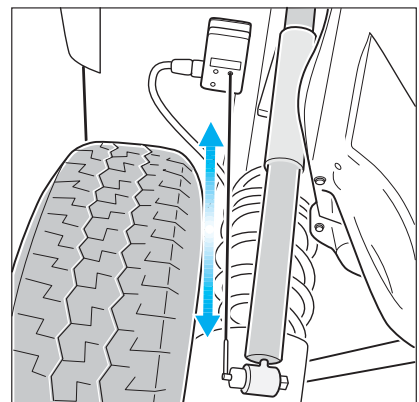
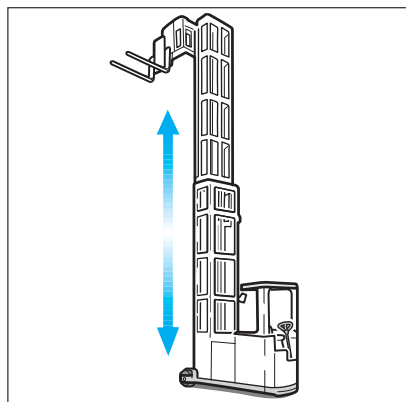
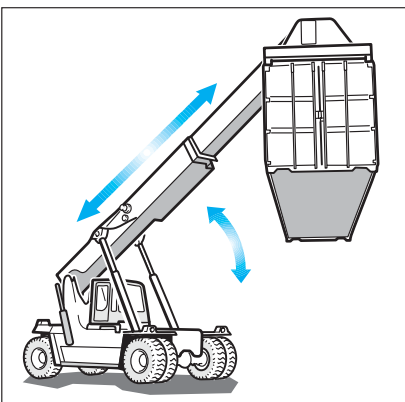
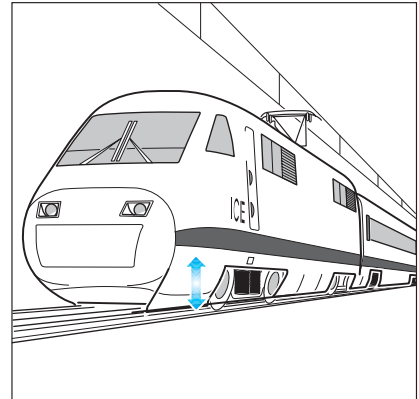
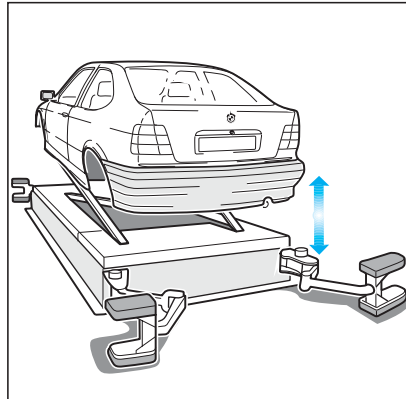
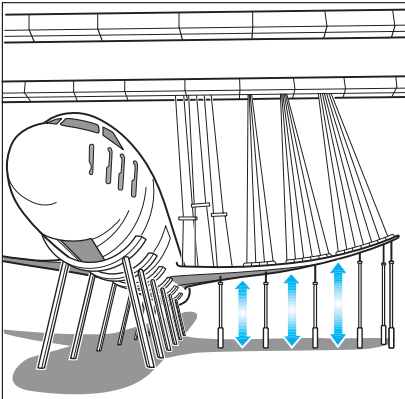

# More ASM Position Sensors

## POSICHRON® – Magnetostrictive Position Sensors



### POSICHRON® – the functional principle

POSICHRON® is an absolute, contact-free and wear-free position measuring system. It is extremely sturdy making it suitable even for applications where other measuring principles would fail. The availability of various constructions - rod, square profile and ultra-flat profile - means that the system can be adapted to suit all kinds of installation conditions.

The POSICHRON® linear measuring system consists of a magnetostrictive wave guide and a movable magnet for determining position. The measuring principle of POSICHRON® position sensors is based on two physical effects: the Wiedemann effect and the Villari effect.

To create the Wiedemann effect, a current impulse is sent through the POSICHRON® positional sensor's wave guide. This current impulse generates a circular magnetic field which propagates at the speed of light around the wave guide. If this circular magnetic field makes contact with the magnetic field of the position magnet which is moved lengthways, a torsional mechanical-elastic density wave is triggered at the overlap area of the two magnetic fields as a result of magnetostriction. This wave propagates in the POSICHRON® positional sensor at ultrasonic speed.

The sensor head of the POSICHRON® position sensor contains a detector which detects the arrival of this wave. The magneto-elastic Villari effect is used as the method of detection. The position between the detector coil and the magnet which can be moved lengthways along the POSICHRON® sensor is determined by measuring the time difference between the electrical induction current impulse and the voltage pulse generated via the Villari effect in the detector coil (time-of-flight principle).

This time difference can be converted using various well-known methods into analogue or digital output signals. The time-of-flight signals can however also be evaluated directly by commonly-available interface modules or counter and time-measuring devices.

A separate detailed catalog about POSICHRON® Magnetostrictive Position Sensors is available on request.

# How to get to ASM

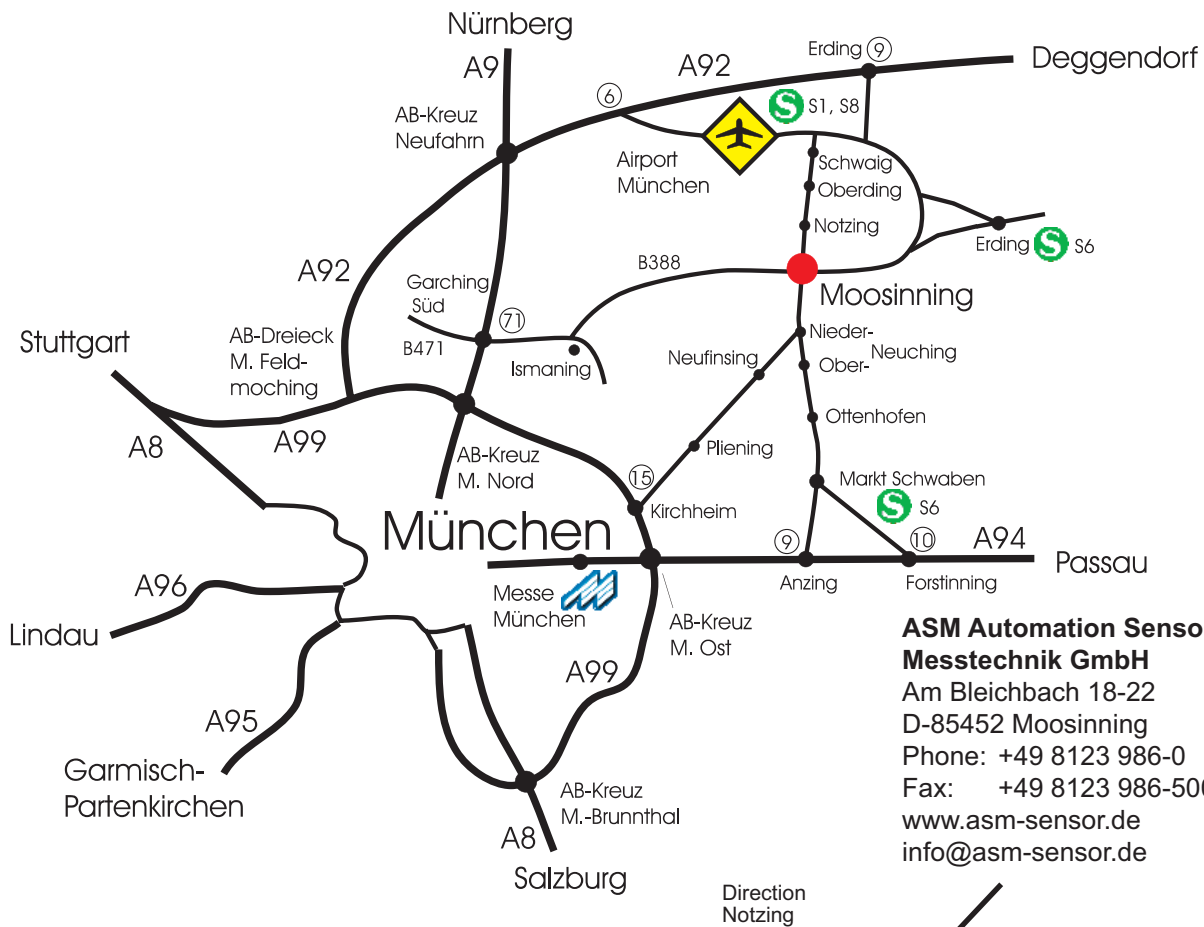

**ASM Automation Sensorik  
Messtechnik GmbH**  
 Am Bleichbach 18-22  
 D-85452 Moosinning  
 Phone: +49 8123 986-0  
 Fax: +49 8123 986-500  
[www.asm-sensor.de](http://www.asm-sensor.de)  
[info@asm-sensor.de](mailto:info@asm-sensor.de)





**perfect in sensors.**

**ASM GmbH**

Am Bleichbach 18 - 22  
D-85452 Moosinning  
Germany  
Tel. +49-(0)8123-986-0  
Fax +49-(0)8123-986-500  
info@asm-sensor.de  
www.asm-sensor.de

**ASM GmbH, Sales Office UK**

Tanyard House, High Street  
Measham, Derbs DE12 7HR  
Great Britain  
Tel. +44-(0)845-1222-123  
Fax +44-(0)845-1222-124  
uk@asm-sensor.com  
www.asm-sensor.com

**ASM GmbH, Agence France**

1, rue du Neuland  
F-67560 Rosheim  
France  
Tel. +33-(0)3-88 49 25 35  
Fax +33-(0)3-88 48 06 23  
france@asm-sensor.com  
www.asm-sensor.com